

AV RECEIVER/AV AMPLIFIER

RX-V1600/DSP-AX1600

SERVICE MANUAL

IMPORTANT NOTICE

This manual has been provided for the use of authorized YAMAHA Retailers and their service personnel. It has been assumed that basic service procedures inherent to the industry, and more specifically YAMAHA Products, are already known and understood by the users, and have therefore not been restated.

WARNING: Failure to follow appropriate service and safety procedures when servicing this product may result in personal injury, destruction of expensive components, and failure of the product to perform as specified. For these reasons, we advise all YAMAHA product owners that any service required should be performed by an authorized YAMAHA Retailer or the appointed service representative.

IMPORTANT: The presentation or sale of this manual to any individual or firm does not constitute authorization, certification or recognition of any applicable technical capabilities, or establish a principle-agent relationship of any form.

The data provided is believed to be accurate and applicable to the unit(s) indicated on the cover. The research, engineering, and service departments of YAMAHA are continually striving to improve YAMAHA products. Modifications are, therefore, inevitable and specifications are subject to change without notice or obligation to retrofit. Should any discrepancy appear to exist, please contact the distributor's Service Division.

WARNING: Static discharges can destroy expensive components. Discharge any static electricity your body may have accumulated by grounding yourself to the ground buss in the unit (heavy gauge black wires connect to this buss).

IMPORTANT: Turn the unit OFF during disassembly and part replacement. Recheck all work before you apply power to the unit.

■ CONTENTS

TO SERVICE PERSONNEL	2	DISPLAY DATA	60~61
FRONT PANELS	3	IC DATA	62~69
REAR PANELS	4~6	BLOCK DIAGRAM	71~73
REMOTE CONTROL PANELS	7	PIN CONNECTION DIAGRAM	74~75
SPECIFICATIONS / 参考仕様	8~10	PRINTED CIRCUIT BOARD	76~97
INTERNAL VIEW	11	SCHEMATIC DIAGRAM	99~111
DISASSEMBLY PROCEDURES / 分解手順	12~15	PARTS LIST	113~146
UPDATING FIRMWARE / ファームウェアの書き込み	16~23	REMOTE CONTROL	147~149
SELF DIAGNOSIS FUNCTION (DIAG) / 自己診断機能 (ダイアグ)	24~57	ADVANCED SETUP / アドバンスドセットアップメニューを設定する	150
AMP ADJUSTMENT / アンプ部調整	58~59	Parts List for Carbon Resistors	151



このサービスマニュアルは、エコマーク認定の再生紙を使用しています。
This Service Manual uses recycled paper.

100981

© 2005 YAMAHA CORPORATION All rights reserved
This manual is copyrighted by YAMAHA and may not be copied or
redistributed either in print or electronically without permission



YAMAHA

YAMAHA CORPORATION
P.O.Box 1, Hamamatsu, Japan

S'05 11

■ TO SERVICE PERSONNEL

1. Critical Components Information
Components having special characteristics are marked \triangle and must be replaced with parts having specifications equal to those originally installed.
 2. Leakage Current Measurement (For 120V Models Only)
When service has been completed, it is imperative to verify that all exposed conductive surfaces are properly insulated from supply circuits.
- Meter impedance should be equivalent to 1500 ohms shunted by 0.15 μ F.

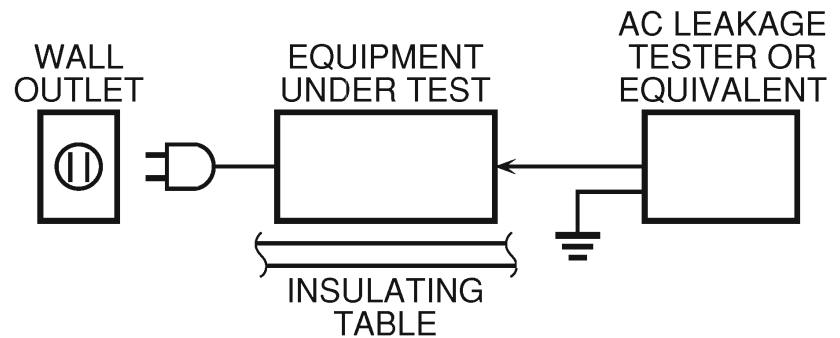

- Leakage current must not exceed 0.5mA.
- Be sure to test for leakage with the AC plug in both polarities.



“CAUTION”

“F2: FOR CONTINUED PROTECTION AGAINST RISK OF FIRE, REPLACE ONLY WITH SAME TYPE 10A, 125V FUSE.”

CAUTION

F2: REPLACE WITH SAME TYPE 10A, 125V FUSE.

ATTENTION

F2: UTILISER UN FUSIBLE DE RECHANGE DE MEME TYPE DE 10A, 125V.

WARNING: CHEMICAL CONTENT NOTICE!

The solder used in the production of this product contains LEAD. In addition, other electrical/electronic and/or plastic (where applicable) components may also contain traces of chemicals found by the California Health and Welfare Agency (and possibly other entities) to cause cancer and/or birth defects or other reproductive harm.

DO NOT PLACE SOLDER, ELECTRICAL/ELECTRONIC OR PLASTIC COMPONENTS IN YOUR MOUTH FOR ANY REASON WHATSOEVER!

Avoid prolonged, unprotected contact between solder and your skin! When soldering, do not inhale solder fumes or expose eyes to solder/flux vapor!

If you come in contact with solder or components located inside the enclosure of this product, wash your hands before handling food.

About lead free solder / 無鉛ハンダについて

The P.C.B.s installed in this unit are soldered using the following solder.

本機に搭載されている基板のハンダ付けに使用されているハンダは下記の通りです。

	Side A / A 面	Side B / B 面
DSP P.C.B.	Lead Free Solder / 無鉛ハンダ	Lead Free Solder / 無鉛ハンダ
FUNCTION P.C.B.	Lead Free Solder / 無鉛ハンダ	Lead Free Solder / 無鉛ハンダ
OPERATION P.C.B.	-	Lead Free Solder / 無鉛ハンダ
MAIN P.C.B.	-	Lead Free Solder / 無鉛ハンダ
POWER PC.B.	-	Lead Free Solder / 無鉛ハンダ
INPUT P.C.B.	Lead Free Solder / 無鉛ハンダ	Lead Free Solder / 無鉛ハンダ
A-VIDEO P.C.B.	Lead Free Solder / 無鉛ハンダ	Lead Free Solder / 無鉛ハンダ
D-VIDEO P.C.B.	Lead Free Solder / 無鉛ハンダ	Lead Free Solder / 無鉛ハンダ

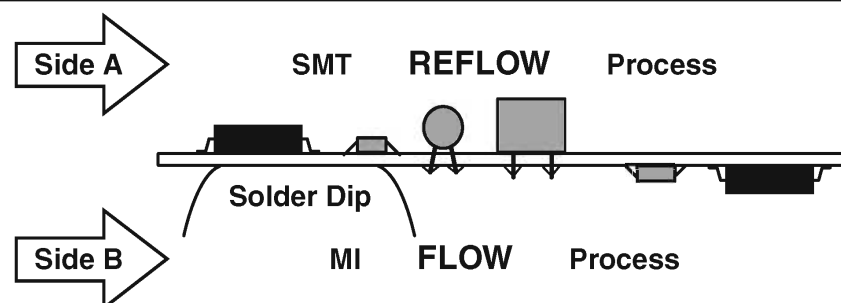

Among some types of lead free solder currently available, it is recommended to use one of the following types for the repair work.

- Sn + Ag + Cu (tin + silver + copper)
- Sn + Cu (tin + copper)
- Sn + Zn + Bi (tin + zinc + bismuth)

無鉛ハンダにはいくつかの種類がありますが、修理時には下記のような無鉛ハンダの使用を推奨します。

- Sn+Ag+Cu (錫+銀+銅)
- Sn+Cu (錫+銅)
- Sn+Zn+Bi (錫+亜鉛+ビスマス)

Caution:

1. As the melting point temperature of the lead free solder is about 30°C to 40°C (50°F to 70°F) higher than that of the lead solder, be sure to use a soldering iron suitable to each solder.
2. If lead solder must be used, be sure to remove lead free solder from each terminal section of the parts to be replaced and from the area around it completely before soldering, or make sure that the lead-free solder and lead solder melt together fully.

注意:

- ① 無鉛ハンダの融点温度は通常の鉛入りハンダに比べ30～40°C程度高くなっていますので、それぞれのハンダに合ったハンダごてをご使用ください。
- ② 鉛入りハンダを使わざるを得ない場合は、あらかじめ交換する部品端子部やその周辺部の無鉛ハンダをすべて取り除くか、あるいは無鉛ハンダと鉛入りハンダが十分に溶けた状態となるようにハンダ付けしてください。

FRONT PANELS

RX-V1600 (U, C models)

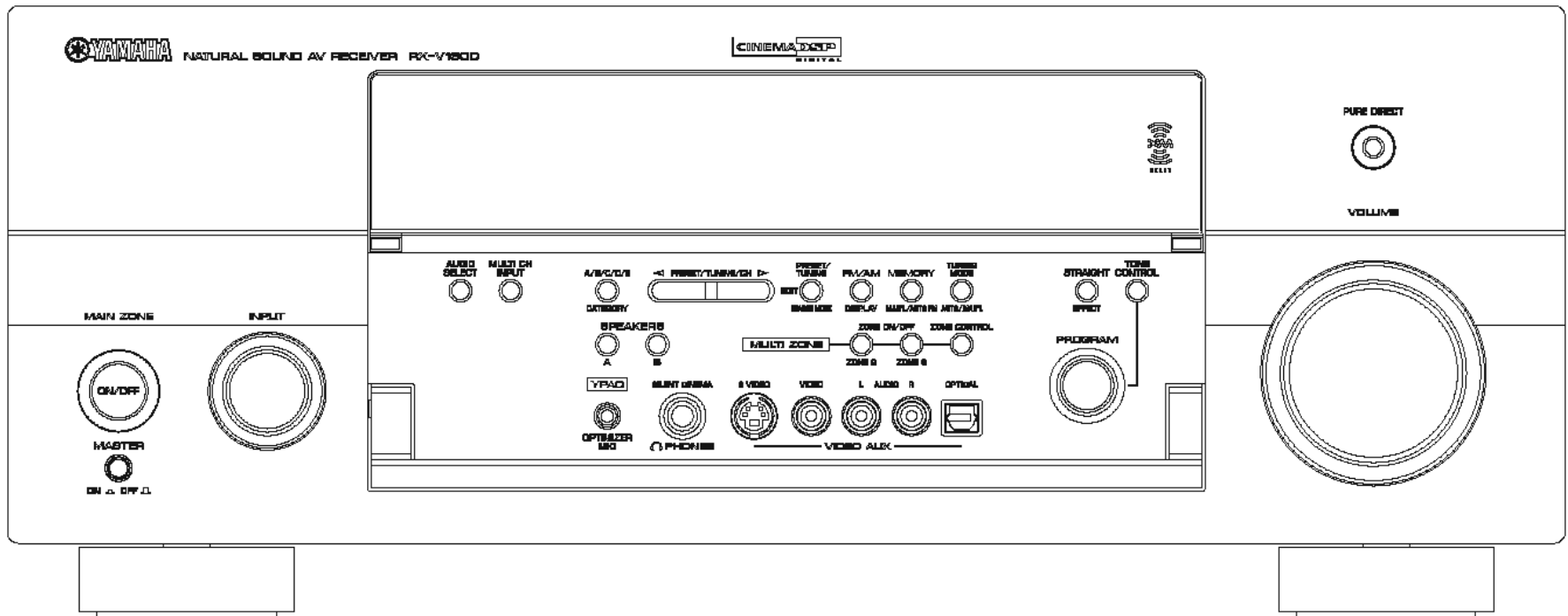

RX-V1600 (R, T, K, A, B, G, L models)

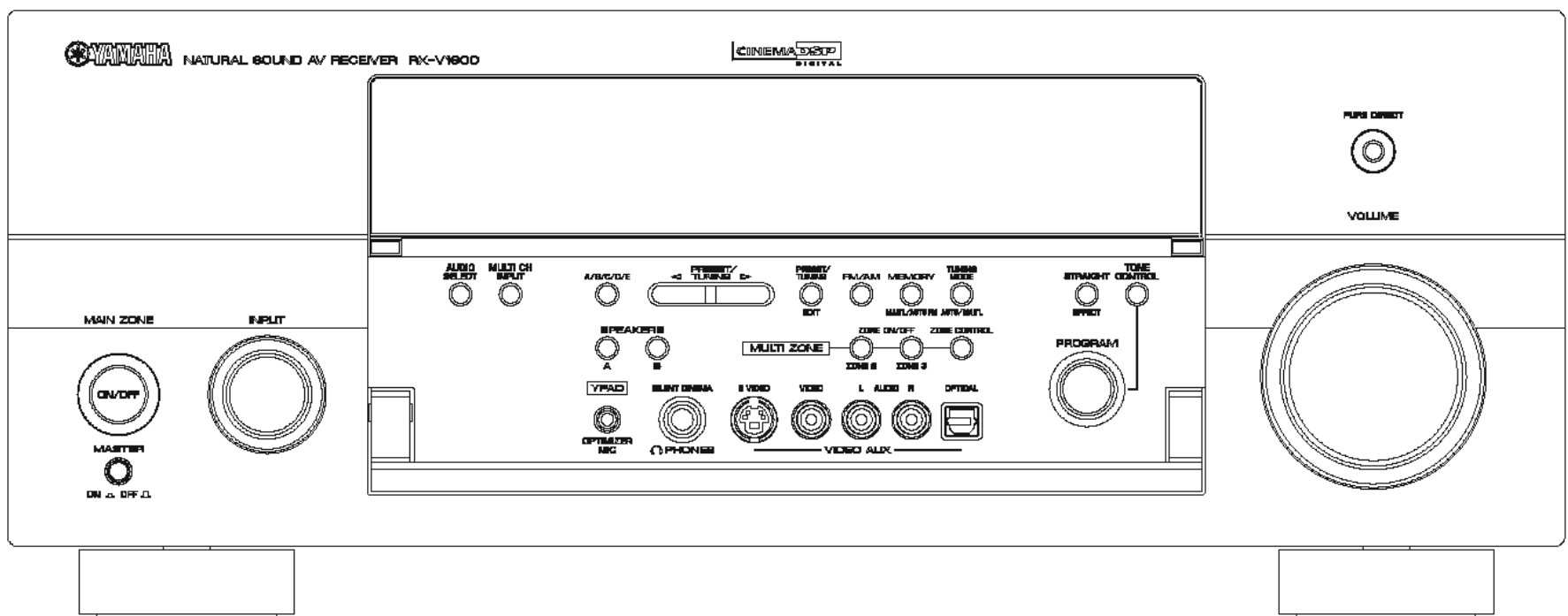

DSP-AX1600 (J model)

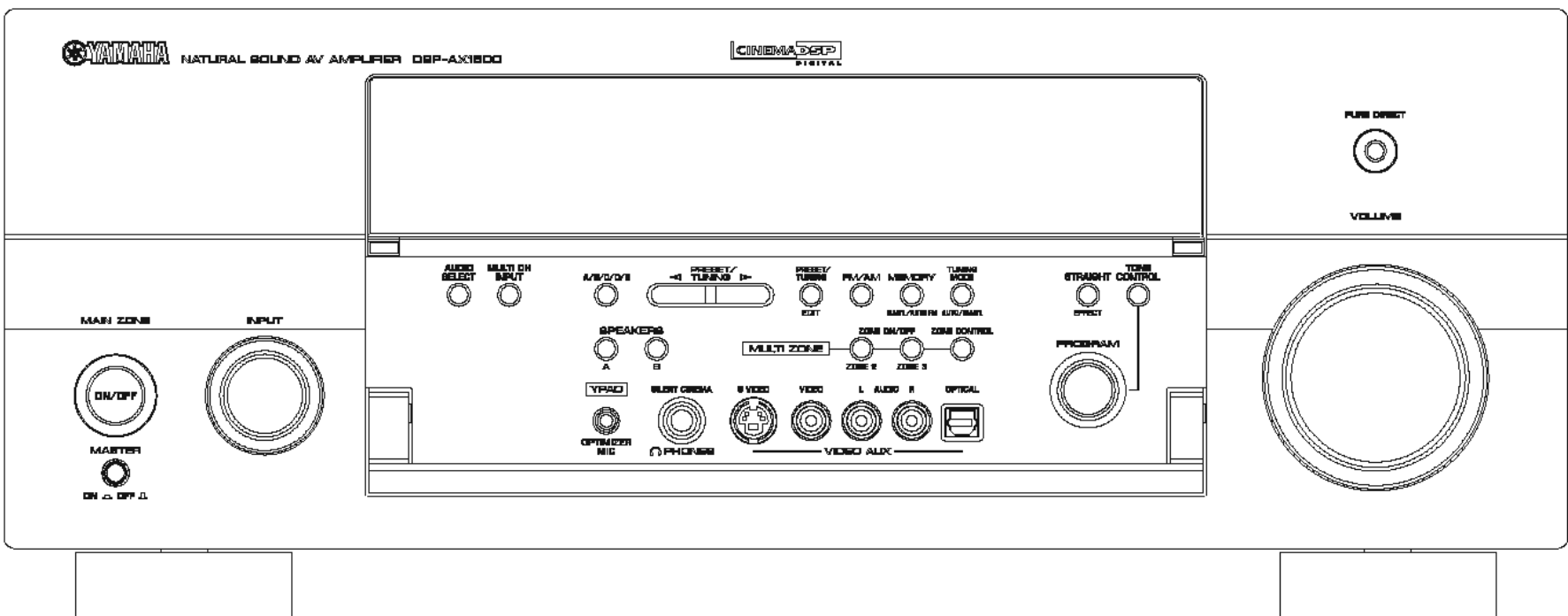

RX-V1600/DSP-AX1600

REAR PANELS

RX-V1600 (U, C models)

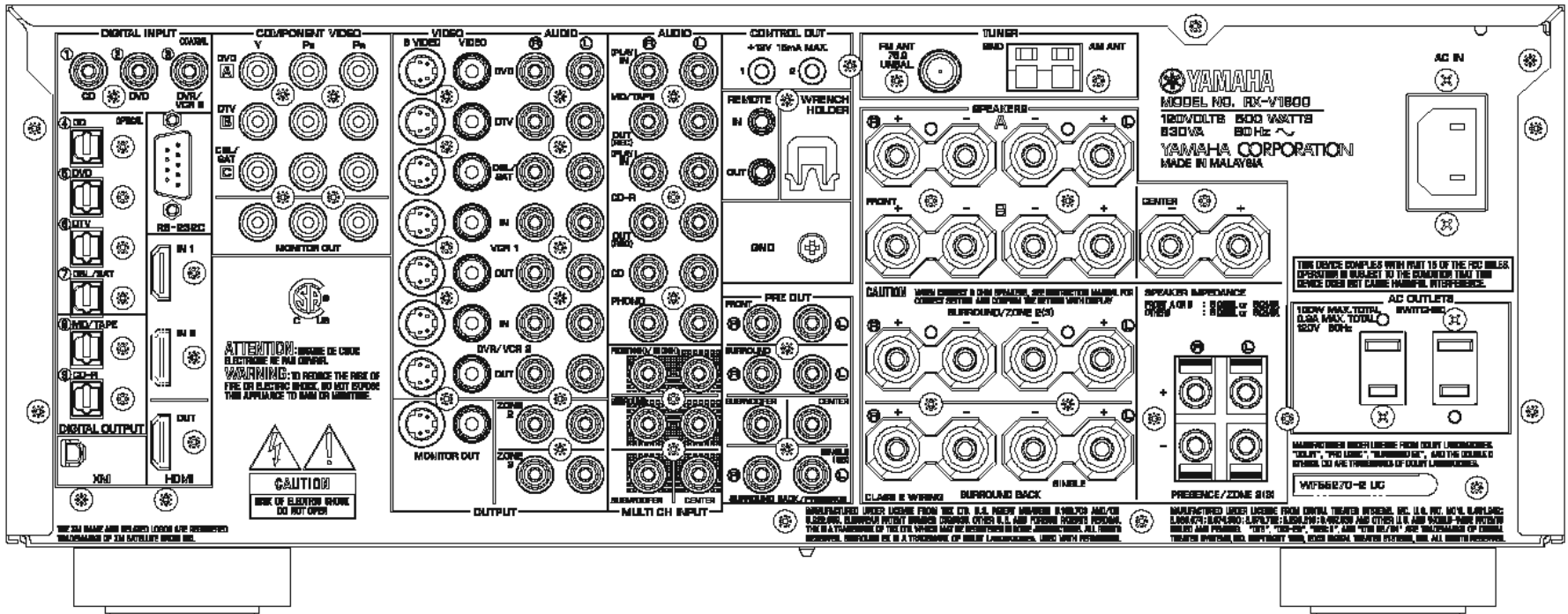

RX-V1600 (R model)

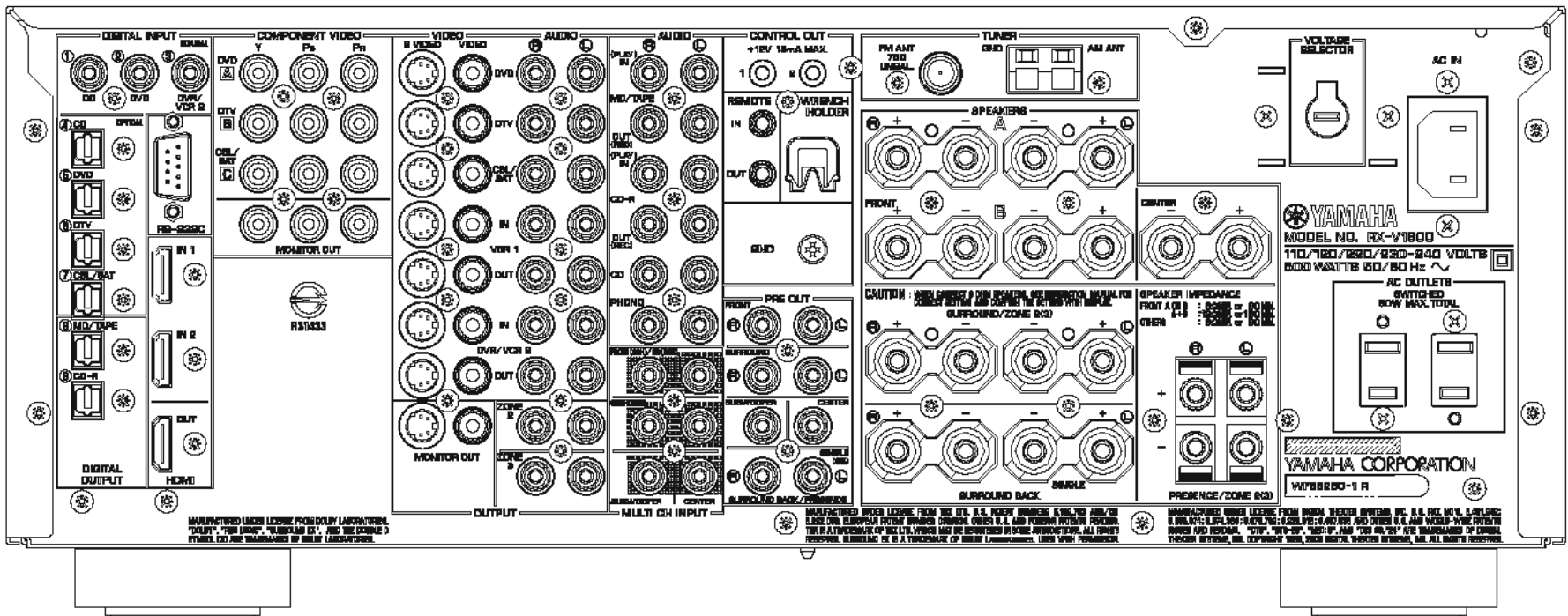

RX-V1600 (T model)

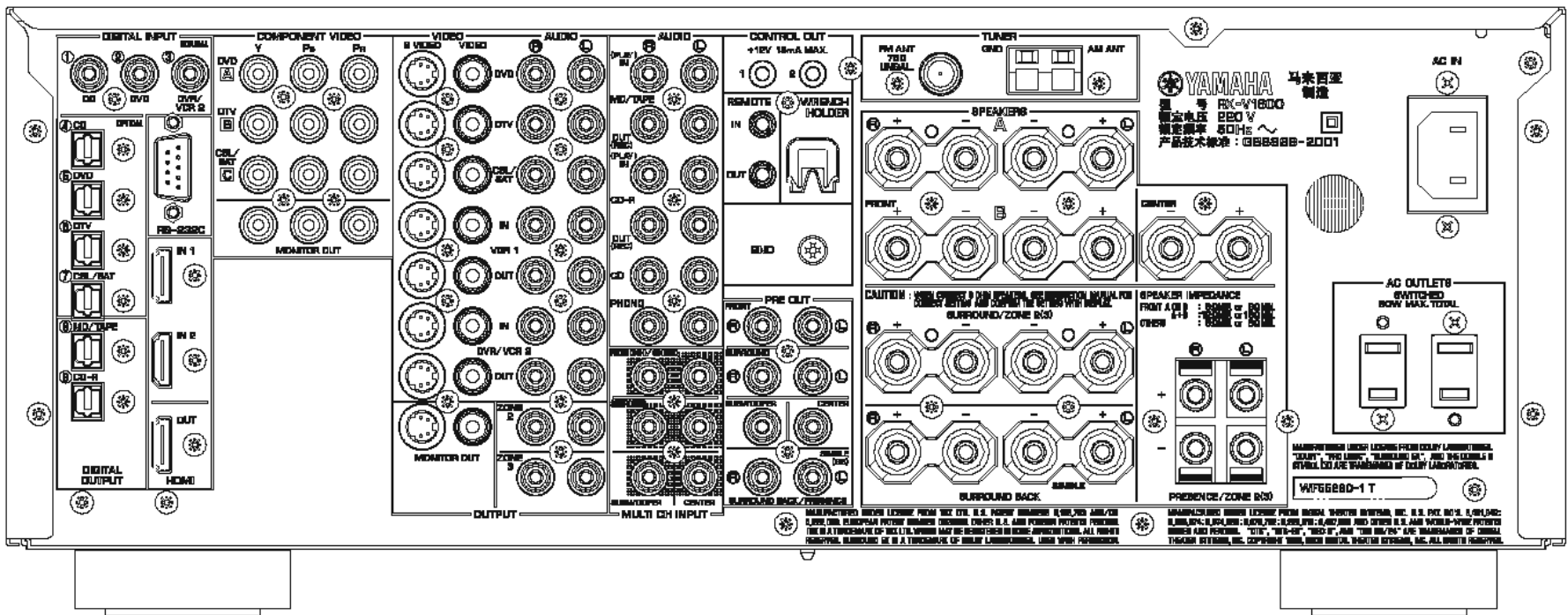

RX-V1600 (K model)

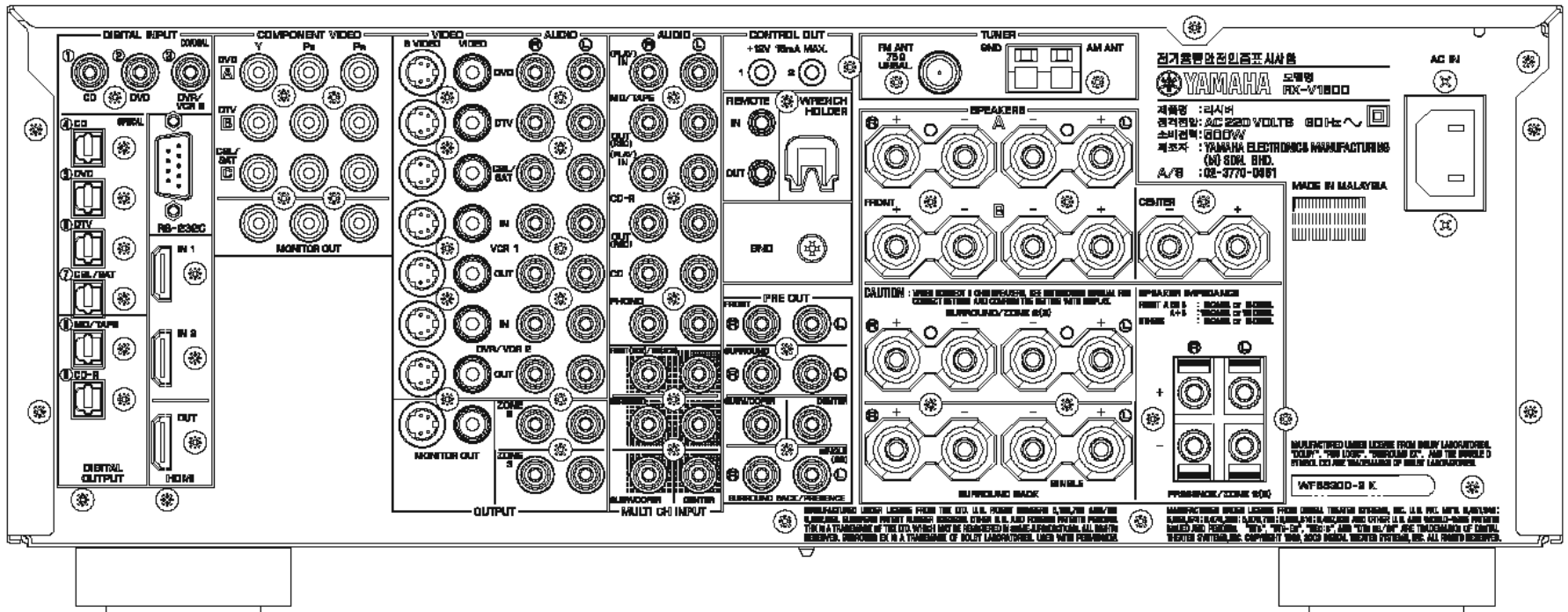

RX-V1600 (A model)

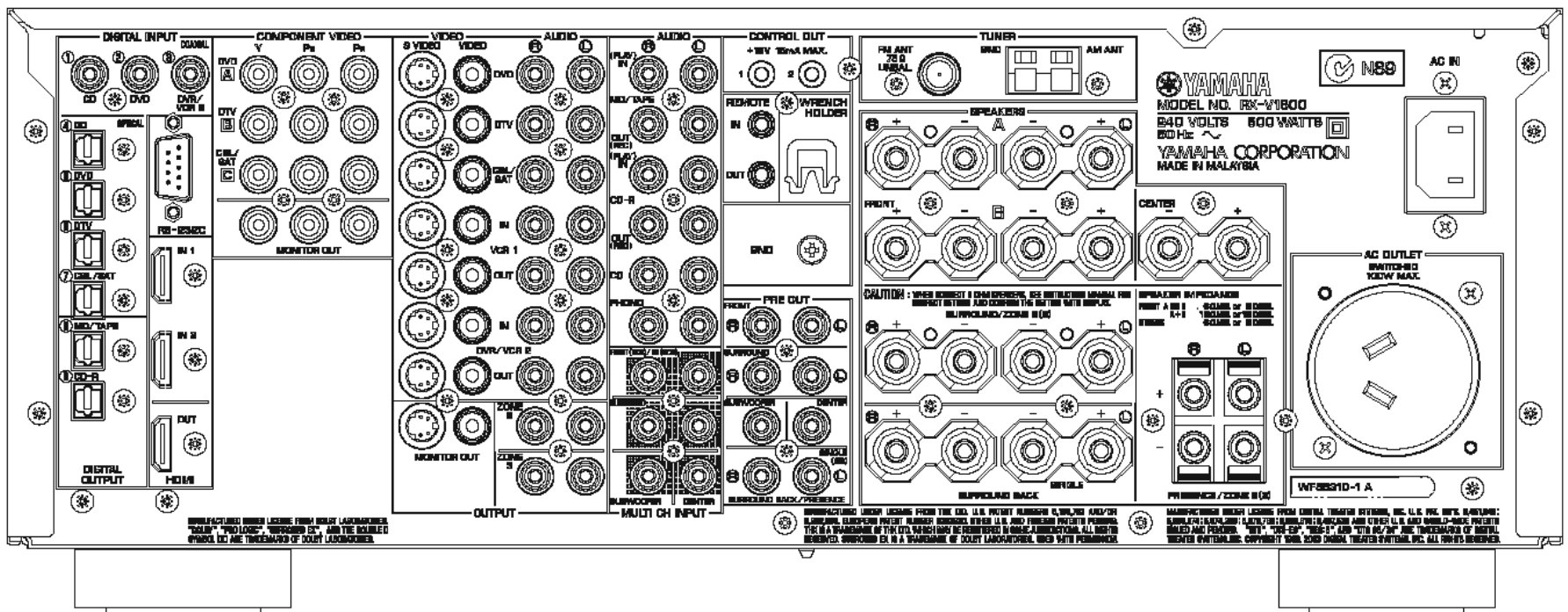

RX-V1600 (B model)

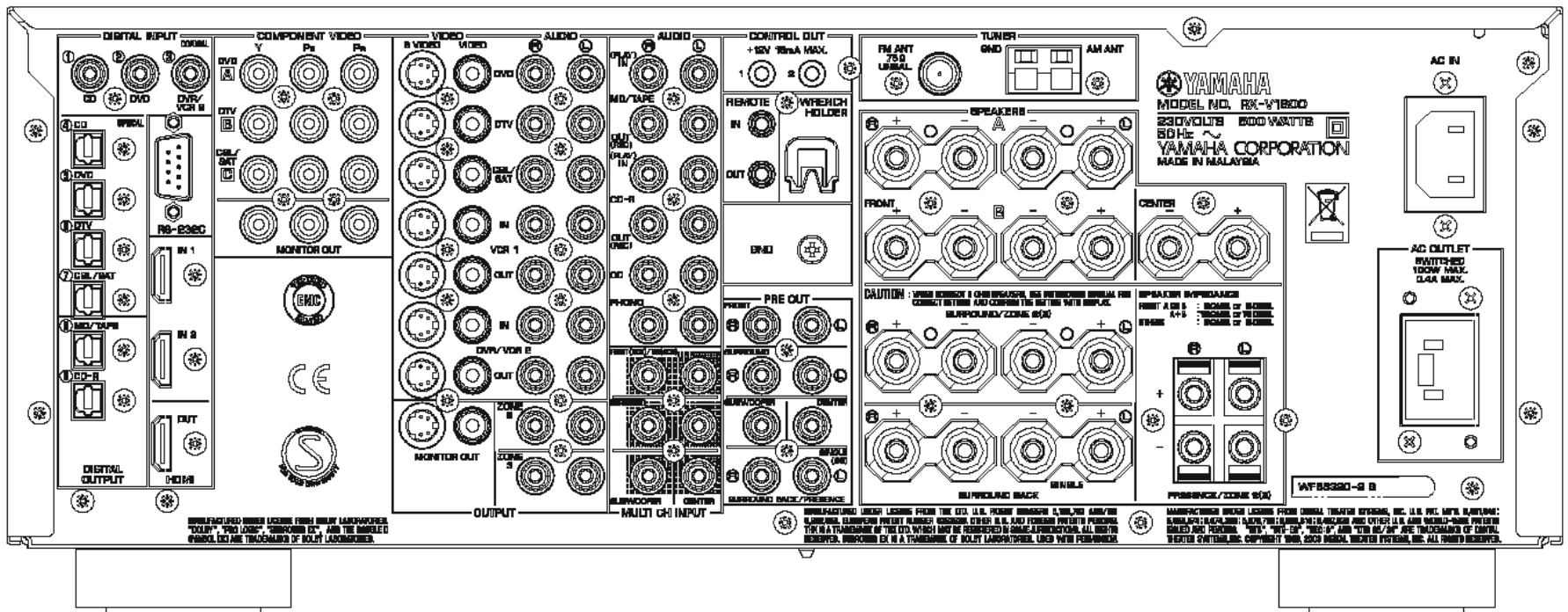

RX-V1600/DSP-AX1600

RX-V1600 (G model)

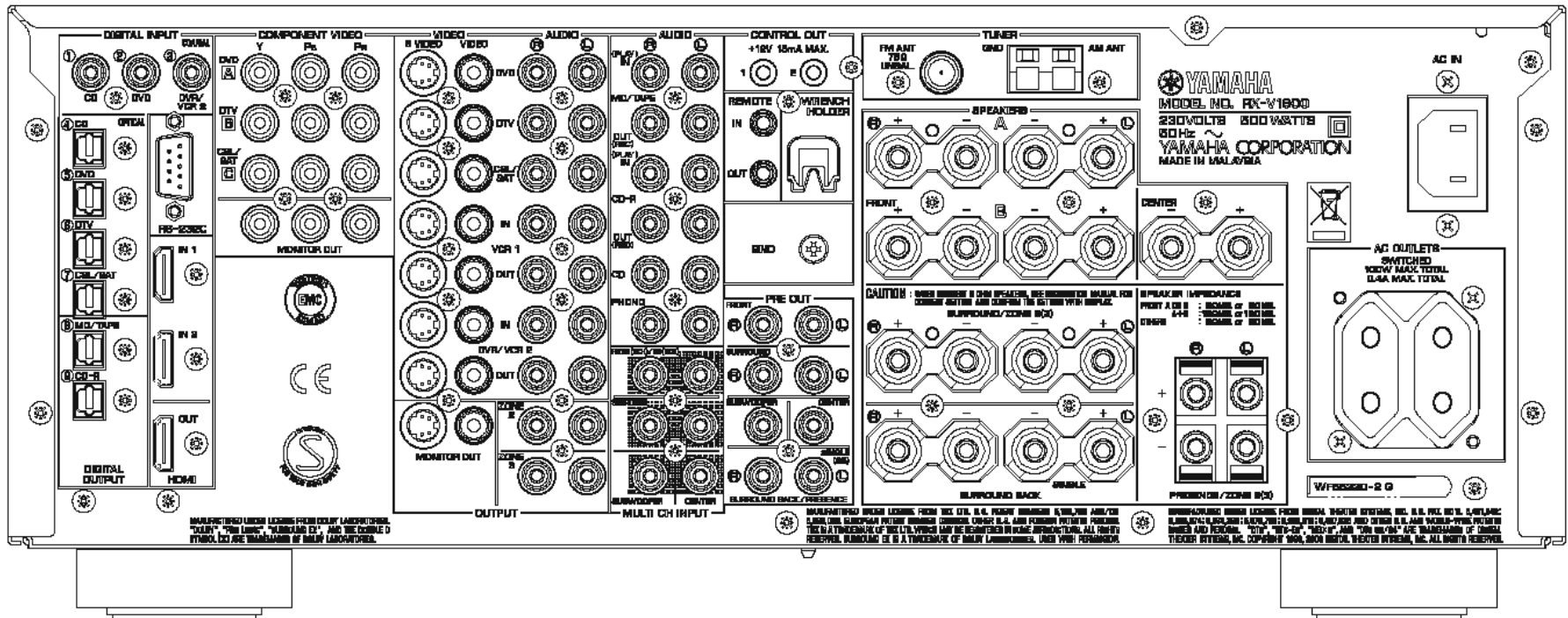

RX-V1600 (L model)

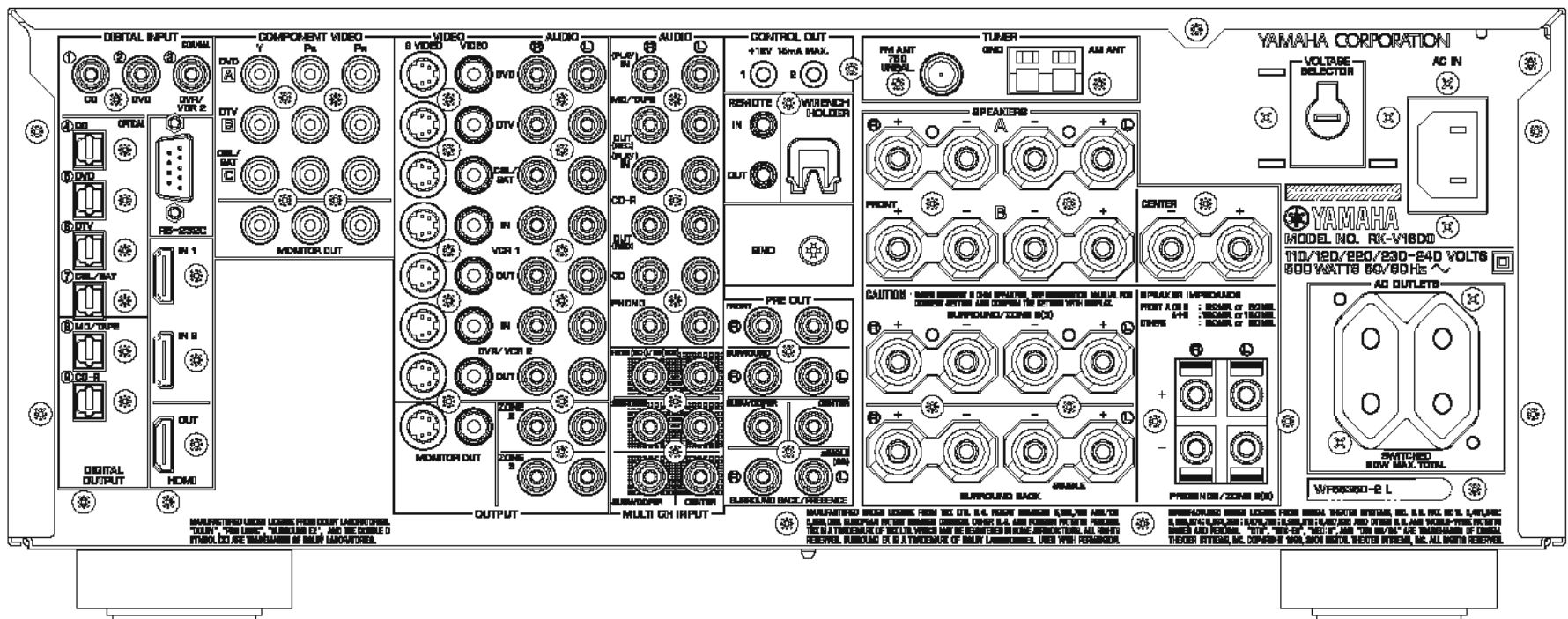

DSP-AX1600 (J model)

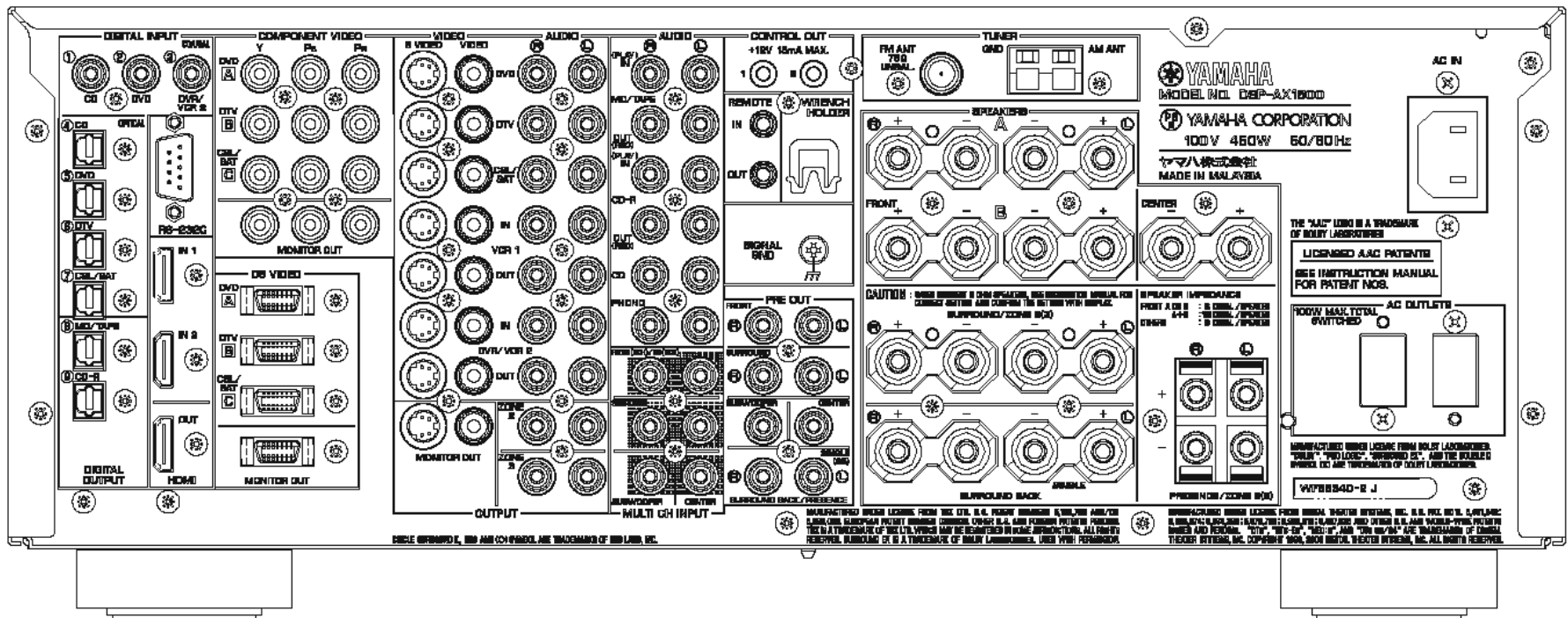

REMOTE CONTROL PANELS

RX-V1600 (U, C models)

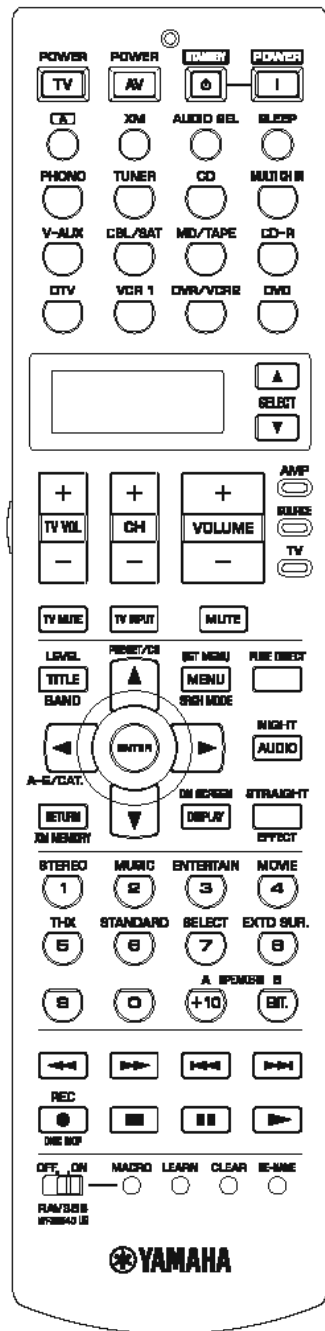

RX-V1600 (R, T, K, A, B, G, L models)
DSP-AX1600 (J model)

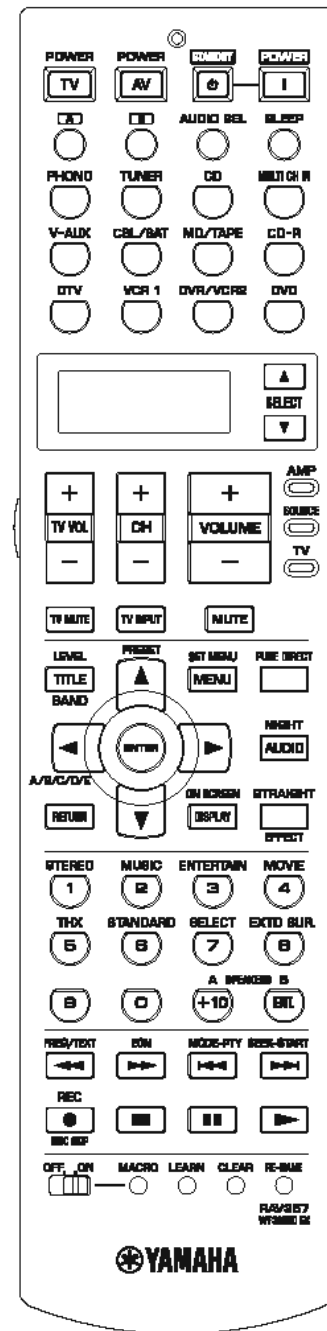

RX-V1600 (U, C models)

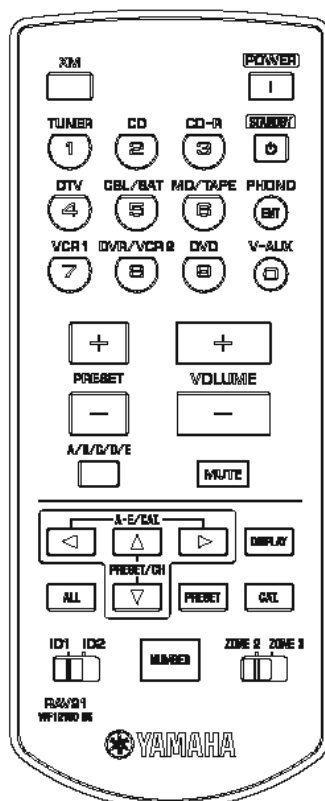

RX-V1600 (R, T, K, A, B, G, L models)
DSP-AX1600 (J model)

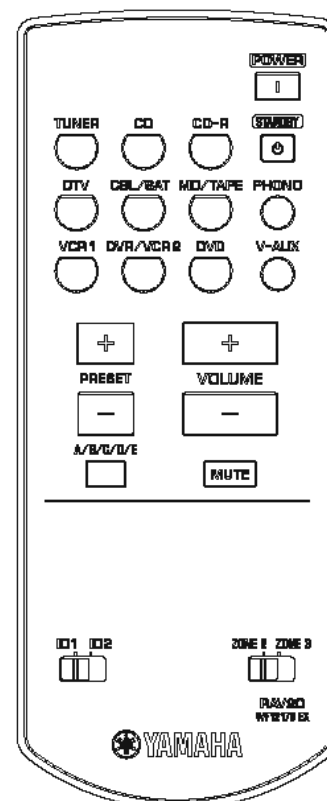

■ SPECIFICATIONS / 参考仕様

■ Audio Section / オーディオ部

Minimum RMS Output Power (Power Amp. Section) / 定格出力 (パワーアンプ部) (20 Hz to 20 kHz)

FRONT L/R	
U, C, R, T, K, A, B, G, L models (0.04 % THD, 8 ohms) ..	120 W + 120 W
J model (0.06 % THD, 6 ohms) ..	120 W + 120 W
CENTER	
U, C, R, T, K, A, B, G, L models (0.04 % THD, 8 ohms) ...	120 W
J model (0.06 % THD, 6 ohms) ..	120 W
SURROUND L/R	
U, C, R, T, K, A, B, G, L models (0.04 % THD, 8 ohms) ..	120 W + 120 W
J model (0.06 % THD, 6 ohms) ..	120 W + 120 W
SURROUND BACK L/R	
U, C, R, T, K, A, B, G, L models (0.04 % THD, 8 ohms) ..	120 W + 120 W
J model (0.06 % THD, 6 ohms) ..	120 W + 120 W

Maximum Power / 実用最大出力 (EIAJ, 1kHz, 10 % THD)

FRONT L/R	
R, T, K, L models (8 ohms) ..	170 W + 170 W
J model (6 ohms) ..	170 W + 170 W
CENTER	
R, T, K, L models (8 ohms) ..	170 W
J model (6 ohms) ..	170 W
SURROUND L/R	
R, T, K, L models (8 ohms) ..	170 W + 170 W
J model (6 ohms) ..	170 W + 170 W
SURROUND BACK L/R	
R, T, K, L models (8 ohms) ..	170 W + 170 W
J model (6 ohms) ..	170 W + 170 W

Dynamic Power Per Channel / ダイナミックパワー (IHF)

U, C, R, T, K, A, L models (8/6/4/2 ohms) ..	155/195/250/330 W
--	-------------------

Max. Power Per Channel / Max.パワー [B, G models] (1 kHz, 0.7 % THD, 4 ohms)

FRONT L/R ..	170 W + 170 W
CENTER ..	170 W
SURROUND L/R ..	170 W + 170 W
SURROUND BACK L/R ..	170 W + 170 W

Dynamic Headroom / ダイナミックヘッドルーム

U, C, R, T, K, A, L models (8 ohms) ..	1.03 dB
--	---------

IEC Power / IECパワー [B, G models] (1 kHz, 0.04 % THD, 8 ohms)

FRONT L/R ..	125 W + 125 W
--------------	---------------

Damping Factor / ダンピングファクタ

FRONT L/R (20 Hz to 20 kHz, SPEAKER-A, 8 ohms) ..	140 or more
---	-------------

Input Sensitivity / Input Impedance (入力感度/入力インピーダンス)

PHONO (MM) ..	3.5 mV / 47 k-ohms
CD, etc. ..	200 mV / 47 k-ohms
MULTI CH INPUT	
FRONT L/R, CENTER, SURROUND L/R, SUBWOOFER ..	200 mV / 47 k-ohms

Maximum Input Signal Level / 最大許容入力

PHONO (MM) (1 kHz, 0.1 % THD) ..	60 mV or more
CD, etc. (1 kHz, 0.5 % THD) ..	2.4 V or more

Output Level / Output Impedance (出力電圧/出力インピーダンス)

REC OUT ..	200 mV / 1.2 k-ohms
PRE OUT (FRONT L/R, CENTER, SURROUND L/R, SURROUND BACK L/R) ..	1.0 V / 500 ohms
SUBWOOFER (20 Hz) ..	2.0 V / 500 ohms
ZONE 2 OUT ..	1.0 V / 1.2 k-ohms
ZONE 3 OUT ..	1.0 V / 1.2 k-ohms

Headphone Jack Rated Output / Impedance (ヘッドフォン出力/出力インピーダンス)

CD, etc. (1 kHz, 40 mV, 8 ohms) ..	150 mV / 100 ohms
------------------------------------	-------------------

Frequency Response / 周波数特性

CD, etc. to FRONT L/R (10 Hz to 100 kHz) ..	+0/-3.0 dB
---	------------

RIAA Equalization Deviation / RIAA偏差

20 Hz to 20 kHz, PHONO (MM) ..	0±0.5 dB
--------------------------------	----------

Total Harmonic Distortion / 全高調波歪率 (20 Hz to 20 kHz)

PHONO (MM) to REC OUT (1V) ..	0.02% or less
CD, etc. (STEREO) to FRONT L/R SP OUT (60 W, 8 ohms) ..	0.04% or less

Signal to Noise Ratio / 信号対雑音比 (IHF-A network)

PHONO (MM) (Input shorted) to SP OUT	
U, C, R, T, K, A, B, G, L models (5 mV) ..	81 dB or more
J model (2.5 mV) ..	75 dB or more
CD, etc. (Input shorted, STEREO) to SP OUT	
250 mV ..	100 dB or more

Residual Noise / 残留ノイズ (IHF-A network)

FRONT L/R SP OUT ..	150 μV or less
---------------------	----------------

Channel Separation / チャンネルセパレーション (STEREO)

PHONO (Input shorted, 1 kHz/10 kHz) ..	60 dB or more/55 dB or more
CD, etc. (Input 5.1 k-ohms shorted, 1 kHz/10 kHz) ..	60 dB or more/45 dB or more

Tone Control Characteristics / トーンコントロール特性

BASS	
Boost/Cut ..	±6 dB (50 Hz)
Turnover Frequency ..	350 Hz
TREBLE	
Boost/Cut ..	±6 dB (20 kHz)
Turnover Frequency ..	3.5 kHz

ZONE2, ZONE3 Tone Control Characteristics /

ZONE2、ZONE3 トーンコントロール特性

BASS	
Boost/Cut ..	±10 dB (100 Hz)
Turnover Frequency ..	450 Hz
TREBLE	
Boost/Cut ..	±10 dB (20 kHz)
Turnover Frequency ..	1.5 kHz

Filter Characteristics / フィルター特性

FRONT, CENTER, SURROUND, SURROUND BACK SP Small (H.P.F.) ..	fc=40/60/80/90/100/110/120/160/200 Hz / 12 dB oct.
SUBWOOFER (L.P.F.) ..	fc=40/60/80/90/100/110/120/160/200 Hz / 24 dB oct.

■ Video Section / ビデオ部

Video Signal Type / ビデオ信号方式

Monitor Out (Gray Back)	
U, C, R, K, J models ..	NTSC
T, A, B, G, L models ..	PAL
Video Conversion ..	NTSC/PAL

Composite Video Signal Level / コンポジットビデオ信号

.....	1 Vp-p / 75 ohms
-------	------------------

S-Video Signal Level / Sビデオ信号

Y ..	1 Vp-p / 75 ohms
C ..	0.286 Vp-p / 75 ohms

Component Video Signal Level / コンポーネントビデオ信号

Y ..	1 Vp-p / 75 ohms
Pb/Pr ..	0.7 Vp-p / 75 ohms

Video Maximum Input Level / ビデオ最大許容入力

.....	1.5 Vp-p or more
-------	------------------

Video Signal to Noise Ratio / ビデオ信号対雑音比

.....	60 dB or more
-------	---------------

Monitor Out Frequency Response / モニターアウト周波数帯域

Component Video Signal ..	5 Hz to 100 MHz, ±3 dB
D5-Video Signal (J model) ..	5 Hz to 100 MHz, ±3 dB

■ FM Section / FM部

Tuning Range / 受信周波数範囲

U, C models ..	87.5 to 107.9 MHz
R, L models ..	87.5 to 108.0 / 87.50 to 108.00 MHz
T, K, A, B, G models ..	87.50 to 108.00 MHz
J model ..	76.0 to 90.0 MHz

50dB Quieting Sensitivity / 50dB SN感度 (IHF) (1 kHz, 100 % MOD.)

Mono ..	2.0 μV (17.3 dBf)
Stereo ..	25 μV (39.2 dBf)

Usable Sensitivity / 実用感度 (IHF)

Mono ..	1.0 μV (11.2 dBf)
---------	-------------------

Selectivity / 選択度

at 400 kHz ..	70 dB
---------------	-------

Signal to Noise Ratio / 信号対雑音比 (IHF)

Mono ..	76 dB
Stereo ..	70 dB

Harmonic Distortion / 歪率 (1 kHz)

Mono ..	0.2 %
Stereo ..	0.3 %

Stereo Separation / ステレオセパレーション (1 kHz)

.....	42 dB
-------	-------

Frequency Response / 周波数特性 (20 Hz to 15 kHz)

.....	+0.5 / -2 dB
-------	--------------

Antenna Input / アンテナ入力

.....	75 ohms unbalanced
-------	--------------------

■ AM Section / AM部

Tuning Range / 受信周波数範囲
 U, C models 530 to 1,710 kHz
 R, L models 530 to 1,710 / 531 to 1,611 kHz
 T, K, A, B, G, J models 531 to 1,611 kHz

Usable Sensitivity / 実用感度
 300 µV/m

Antenna Input / アンテナ入力
 Loop Antenna

■ General / 総合

Power Supply / 電源電圧
 U, C models AC 120 V, 60 Hz
 R, L models AC 110/120/220/230-240 V, 50/60 Hz
 T model AC 220 V, 50 Hz
 K model AC 220 V, 60 Hz
 A model AC 240 V, 50 Hz
 B, G models AC 230 V, 50 Hz
 J model AC 100 V, 50/60 Hz

Power Consumption / 消費電力
 U, C models 500 W / 630 VA
 R, T, K, A, B, G, L models 500 W
 J model 450 W

Standby Power Consumption (reference data) / 待機時消費電力(参考値)
 U, C, T, K, A, B, G, L, J models 0.1 W or less
 R model (AC 240 V / 50 Hz) 0.33 W or less

Maximum Power Consumption / 最大消費電力 (6ch Drive, 10% THD)
 R model 1100 W

AC Outlets / ACプラグアウト
 2 switched outlets
 U, C models 100 W max. total / 0.8 A max. total
 R, T, L models 50 W max. total
 G model 100 W max. total / 0.4 A max. total
 J model 100 W max. total

1 switched outlet
 A model 100 W max. total
 B model 100 W max. total / 0.4 A max. total

Dimensions / 寸法 (W x H x D)
 435 x 171 x 438.5 mm (17-1/8" x 6-3/4" x 17-1/4")

Weight / 質量
 RX-V1600/DSP-AX1600 17.4 kg (38 lbs. 6 oz.)

Finish / 仕上げ
 Gold color R, T, K, L, J models
 Black color U, C, R, A, G models
 Titanium color C, T, K, B, G, L models

Accessories / 付属品
 Remote Control x 1, Zone2/3 Remote Control x 1, Batteries (Manganese Dry) x 6, Indoor FM Antenna x 1, AM Loop Antenna x 1, Antenna Adapter PAL x 1 (B model), Power Cable x 1 (U, C, R, T, K, A, B, G, J models), Power Cable x 2 (L model), Speaker Terminal Wrench x 1, Optimizer Microphone x 1

* Specifications are subject to change without notice due to product improvements.

※ 参考仕様および外観は予告なく変更されることがあります。

U U.S.A. model C Canadian model
 R General model T Chinese model
 K Korean model A Australian model
 B British model G European model
 L Singapore model J Japanese model

DD DOLBY DIGITAL EX
 Manufactured under license from Dolby Laboratories.
 "Dolby", "Surround EX", and the double-D symbol are trademarks of Dolby Laboratories.

ドルビーラウドスピーカーからの実機種に基づき製造されています。
 「ドルビー」、「PRO LOGIC」、「Surround EX」および「ダブルD」記号は、ドルビーラウドスピーカーの登録商標です。

CTA 2001
 "DTS", "DTS-ES", "Neo:6" and "DTS 96/24" are trademarks of Digital Theater Systems, Inc.
 DTS, DTS-ES, Extended Surround, Neo:6およびDTS 96/24はデジタルシアターシステムの登録商標です。

HDMI
 "HDMI", the "HDMI" logo and "High-Definition Multimedia Interface" are trademarks or registered trademarks of HDMI Licensing LLC.
 HDMI, HDMIロゴおよびHigh-Definition Multimedia Interfaceは、HDMI Licensing LLCの商標または、登録商標です。

SILENT CINEMA
 "SILENT CINEMA" is a trademark of YAMAHA CORPORATION.
 「サイレントシネマ/SILENT CINEMA」はヤマハ株式会社の登録商標です。

THX
 The THX logo is a trademark of THX Ltd. which may be registered in some jurisdictions. All rights reserved.
 THXとTHXロゴはTHXの登録商標です。不許複製。

READY
 © 2005 XM Satellite Radio Inc. All rights reserved. All other trademarks are the property of their respective owners.

SRS
 Circle Surround II, SRSと記号はSRS Labs, Inc.の商標です。
 AACロコナーはドルビーラウドスピーカーの登録商標です。

• DIMENSIONS / 寸法図

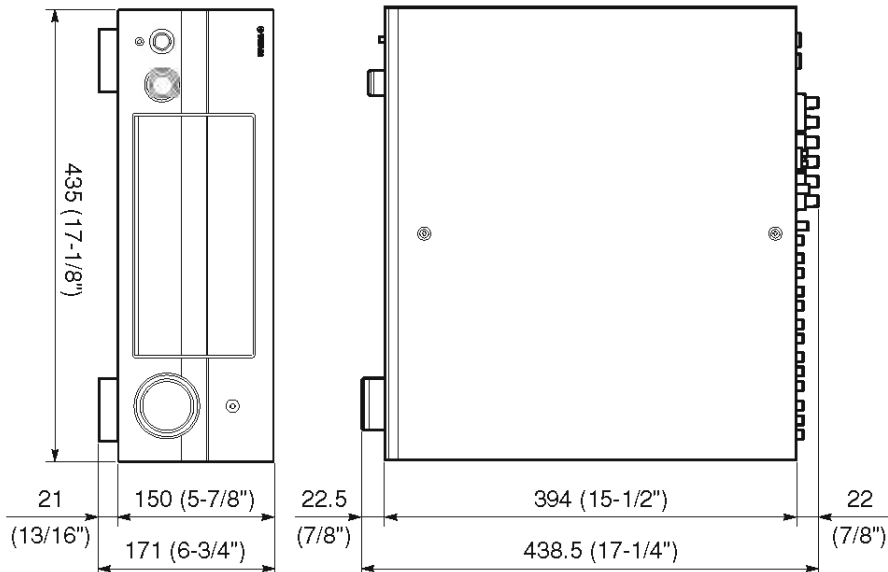

• SOUND/SURROUND SELECT MENU

Sound Select Min./Max./Step 最小/最大/Step

Main Menu	Parameter	Center Level	Surround L Level	Surround R Level	Sur. Back Level	Presence L Level	Presence R Level	Initialize	DIRECT
STEREO	2ch Stereo	0 / 100 / 1 %	0 / 100 / 1 %	0 / 100 / 1 %	0 / 100 / 1 %	0 / 100 / 1 %	0 / 100 / 1 %	NO / YES	AUTO / OFF
	7ch Stereo	-	100	100	50 (LRG1) 35 (LRG2)	33	33	NO	AUTO

Surround Select Min./Max./Step 最小/最大/Step

	Decode Type	DSP Level	Init. Delay	Room Size	Liveness	Sur. Init. Delay	Sur. Room Size	SB Init. Delay	SB Room Size	Rev. Time	Rev. Delay	Rev. Level	Dialogue Lift	Initialize	
MUSIC	Munich	-6/+3/1 dB	1/99/1 ms	0.1/2.0/0.1	0/10/1	1/49/1 ms	0.1/2.0/0.1	1/49/1 ms	0.1/2.0/0.1	10/50/0.1 ms	0/250/1 ms	0/100/1 %	0/5/1	NO	
	Vienna	0	30	1.0	5	-	-	-	-	-	-	-	(0)	NO	
	Freiburg	0	30	1.0	5	-	-	-	-	4.0	130	70	(0)	NO	
	The Bottom Line	0	30	1.0	5	-	-	-	-	-	-	-	(0)	NO	
	The Roxy Theater	0	15	1.0	5	-	-	-	-	1.6	120	9	(0)	NO	
	Pop/Rock	0	21	1.0	-	-	-	-	-	-	-	-	(0)	NO	
	Classical/Opera	0	28	1.0	-	-	-	-	-	-	-	-	(0)	NO	
ENTERTAINMENT	TV Sports	0	10	1.0	-	30	1.0	(15)	(1.0)	1.6	100	4	(0)	NO	
	Mono Movie	0	69	1.0	3	-	-	-	(1.0)	2.5	160	2	(0)	NO	
	Game	0	36	1.0	-	15	1.0	(15)	(1.0)	-	-	-	(0)	NO	
MOVIE THEATER	Spectacle	Disco	0	26	1.0	5	-	-	-	2.7	120	4	(0)	NO	
		Pro Logic	0	13	1.0	-	23	1.0	(15)	(1.0)	-	-	-	(0)	NO
		Pro Logic II x	0	13	1.0	-	32	1.0	15	1.0	-	-	-	(0)	NO
	Sci-Fi	Neo : 6	0	13	1.0	-	32	1.0	15	1.0	-	-	-	(0)	NO
		Pro Logic	0	16	1.0	-	20	1.0	(15)	(1.0)	-	-	-	(0)	NO
		Pro Logic II x	0	16	1.0	-	2	1.0	15	1.0	-	-	-	(0)	NO
	Adventure	Neo : 6	0	16	1.0	-	2	1.0	15	1.0	-	-	-	(0)	NO
		Pro Logic	0	15	1.0	-	20	1.0	(15)	(1.0)	-	-	-	(0)	NO
		Pro Logic II x	0	15	1.0	-	30	1.0	15	1.0	-	-	-	(0)	NO
	General	Neo : 6	0	15	1.0	-	30	1.0	15	1.0	-	-	-	(0)	NO
		Pro Logic	0	15	1.0	-	20	1.0	(15)	(1.0)	-	-	-	(0)	NO
		Pro Logic II x	0	15	1.0	-	26	1.0	15	1.0	-	-	-	(0)	NO
	Neo : 6	0	15	1.0	-	26	1.0	15	1.0	-	-	-	(0)	NO	

Main Menu	Sub Menu	Parameter	Setting value ([Initial value] / 設定値([初期値]))
THX	Cinema	Decode Type	[Pro Logic] Pro Logic II x Neo : 6
SURROUND	Standard	Decode Type	[Pro Logic] PL II x Movie PL II x Music PL II x Game Neo : 6 Cinema Neo : 6 Music CS II Cinema CS II Music
		Panorame	[OFF] / ON
		Dimension	-3/+3/1 [STD]
		Center Width	0/7/1 [3]
		Center Image	0.0/1.0/0.1 [0.3]
		FOCUS	0/8/1 [0]
		Tru Bass	0/8/1 [0]
		Initialize	[NO] / YES

(DSP-AX1600 model / DSP-AX1600モデルのみ)

(Setting can be made when Pro Logic II x is selected / Pro Logic II x 選択時 設定可)

(Setting can be made when Neo:6 Music is selected / Neo:6 Music 選択時 設定可)

(DSP-AX1600 model / DSP-AX1600モデルのみ)

Parameter	Decode Type	DSP Level	Sur. Init. Delay	Sur. Room Size	Sur. Liveness	SB Init. Delay	SB Room Size	SB Liveness	Dialogue Lift	Initialize
Enhanced	Pro Logic	0	20	1.0	3	(15)	(1.0)	(5)	(0)	NO
	Pro Logic II x	0	19	1.0	3	15	1.0	5	(0)	NO
	Neo 6	0	19	1.0	3	15	1.0	5	(0)	NO

● SET MENU TABLE / セットメニュー

AUTO SETUP

MAIN MENU	PARAMETER
SETUP	AUTO / RELOAD
WIRING	CHECK / SKIP
DISTANCE	NATURAL / SKIP / FLAT / FRONT
SIZE	CHECK / SKIP
EQ	START / ENTER
LEVEL	

MANUAL SETUP

MAIN MENU	SUB MENU	PARAMETER	SETTING VALUE () INITIAL VALUE)
1 BASIC	A SPEAKER SET	BASS OUT	[SWFR] / FRONT / BOTH
		FRONT	LARGE / ISMALL
		CENTER	[SMALL] / LARGE / NONE
		SUR. L/R	[SMALL] / LARGE / NONE
		SUR. B	[SMLx2] / LRgx1 / LRgx2 / NONE / SMLx1
		PRESENCE	[NONE] / YES
		Cross Over	40 / 60 / 80 / 90 / 100 / 110 / 120 / 160 / 200 Hz
		SWFR PHASE	[NRM] / REV
		PRIORITY	[SUR. B] / PRES
		FRONT L	
		FRONT R	
		CENTER	
		SURROUND L	
SURROUND R			
SURROUND BACK L			
SURROUND BACK R			
SUBWOOFER			
PRESENCE L			
PRESENCE R			
C SP DISTANCE	UNIT	meters / feet	
FRONT L			
FRONT R			
CENTER			
SURROUND L			
SURROUND R			
SURROUND BACK L			
SURROUND BACK R			
SWFR			
PRESENCE L			
PRESENCE R			
D THX SET	SB Dist.	Under 0.3m / [0.3-1.2m] / Over 1.2m. Under 1ft / [1-4ft] / Over 4ft	
E TEST TONE	TEST TONE	[OFF] / ON	
A EQUALIZER	EQ SELECT	[PEQ] / GEO / OFF	
B LFE LEVEL	SPEAKER HEADPHONE	-20dB ~ ±0.0dB, 1.0dB step [±0.0dB]	
C DYNA. RANGE	SPEAKER HEADPHONE	[MAX] / MIN / STD	
D AUDIO SET	Mute Type	[FULL] / -20dB	
A. DELAY	0 ~ 240ms, 1ms step [0ms]		
T. BYPASS	[AUTO] / OFF		
DUAL MONO (J model)	[MAIN] / SUB / ALL		
S. AUDIO	[1600 (model)] / OTHER		
E HDMI SET	C. V [A]	[DVD]	
C. V [B]	[DTV]		
C. V [C]	[CBL/SAT]		
IN (1)	[CD]		
IN (2)	[DVD]		
IN (3)	[DVR/VCR2]		
IN (4)	[CD]		
IN (5)	[DVD]		
IN (6)	[DTV]		
IN (7)	[CBL/SAT]		
OUT (8)	[MD/TAPE]		
OUT (9)	[CD-R] / [DVD-R] / [PHONO]		
IN1	[DVD]		
IN2	[CBL/SAT]		
3 INPUT	A I/O ASSIGN	DVD / DTV / CBL/SAT / VCR1 / DVR/VCR2 / V-AUX / XM	

MAIN MENU	SUB MENU	PARAMETER	SETTING VALUE () INITIAL VALUE)
	B INPUT RENAME	DVD	
		DVR/VCR2	
		VCR1	
		DTV	
		CD-R	
		MD/TAPE	
		CBL/SAT	
		V-AUX	
		CD	
		TUNER	
		PHONO	
		PHONO	
		C VOLUME TRIM	
D DVD			
DTV			
CBL/SAT			
DVR/VCR2			
MD/TAPE			
DVD			
DTV			
CBL/SAT			
VCR1			
DVR/VCR2			
V-AUX			
D DECODER MODE	CD		
DVD			
DTV			
CBL/SAT			
DVR/VCR2			
MD/TAPE			
DVD			
DTV			
VCR1			
V-AUX			
E MULTICH INPUT	INPUT CH	[6CH] / 8CH	
A DISPLAY SET	DIMMER	-4 ~ 0, 1 step [0]	
OSD SHIFT	[AUTO] / OFF		
GRAY BACK	[AUTO] / OFF		
V CONV.	[ON] / OFF		
COMPNT I/P	[ON] / OFF		
HDMI I/P	[ON] / OFF		
B MEMORY GUARD	[OFF] / ON		
C AUDIO SELECT	[AUTO] / LAST		
D DECODER MODE	[AUTO] / LAST		
E PARAM. INI			
STEREO			
MUSIC			
ENTERTAIN			
MOVIE			
STANDARD			
F ZONE SET	SP B	[MAIN] / ZONE B	
ZONE2 VOL	[VAR] / FIX		
ZONE3 VOL			
ZONE2 AMP	[EXT] / SUR / PRNS / BOTH		
ZONE3 AMP			
G XM RADIO SET	DISP	[OFF] / [10s] / 30s / ON	
(U. C models)	ANTENNA	NONE, 0 ~ 100%	

INTERNAL VIEW

RX-V1600/DSP-AX1600

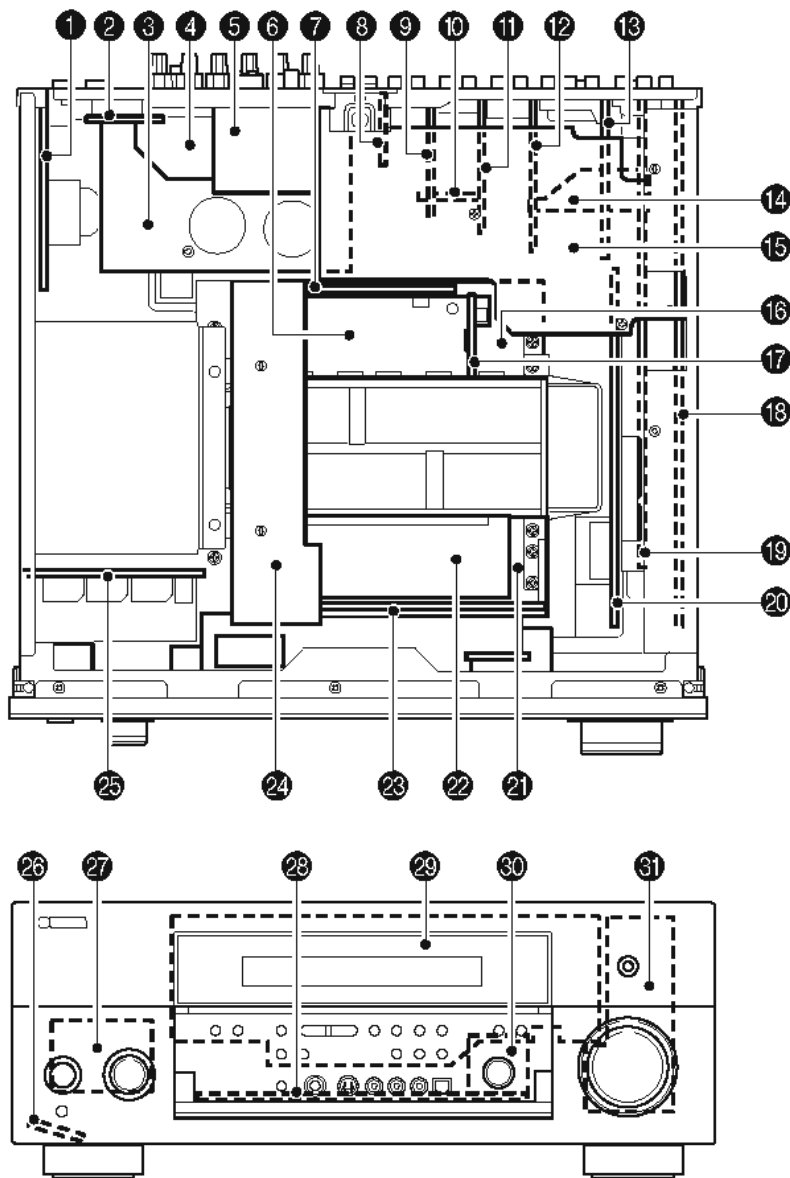

- ① POWER (2) P.C.B.
- ② POWER (6) P.C.B. (R, L models)
- ③ MAIN (1) P.C.B.
- ④ MAIN (5) P.C.B.
- ⑤ TUNER
- ⑥ MAIN (3) P.C.B.
- ⑦ POWER (4) P.C.B.
- ⑧ INPUT (3) P.C.B.
- ⑨ INPUT (1) P.C.B.
- ⑩ INPUT (4) P.C.B.
- ⑪ INPUT (2) P.C.B.
- ⑫ A-VIDEO (2) P.C.B.
- ⑬ A-VIDEO (1) P.C.B.
- ⑭ INPUT (5) P.C.B.
- ⑮ FUNCTION (1) P.C.B.
- ⑯ MAIN (2) P.C.B.
- ⑰ POWER (7) P.C.B.
- ⑱ DSP P.C.B.
- ⑲ D-VIDEO P.C.B.
- ⑳ FUNCTION (2) P.C.B.
- ㉑ MAIN (4) P.C.B.
- ㉒ POWER (5) P.C.B.
- ㉓ POWER (1) P.C.B.
- ㉔ OPERATION (6) P.C.B.
- ㉕ POWER (3) P.C.B.
- ㉖ OPERATION (5) P.C.B.
- ㉗ OPERATION (1) P.C.B.
- ㉘ OPERATION (3) P.C.B.
- ㉙ INPUT (6) P.C.B.
- ㉚ OPERATION (4) P.C.B.
- ㉛ OPERATION (2) P.C.B.

■ DISASSEMBLY PROCEDURES / 分解手順

(Remove parts in the order as numbered.)

Disconnect the power cable from the AC outlet.

(番号順に部品を取り外してください。)

AC電源コンセントから、電源コードを抜いてください。

1. Removal of Top Cover

- a. Remove 2 screws (①), 4 screws (②) and 5 screws (③). (Fig. 1)
- b. Slide the Top Cover rearward to remove it. (Fig. 1)

1. トップカバーの外し方

- a. ①のネジ2本、②のネジ4本、③のネジ5本を外します。(Fig. 1)
- b. トップカバーを後方へスライドさせ、取り外します。(Fig. 1)

2. Removal of Front Panel

Remove 6 screws (④) and then remove the Front Panel Unit forward. (Fig. 1)

2. フロントパネルの外し方

④のネジ6本を外し、フロントパネルを前方に外します。(Fig. 1)

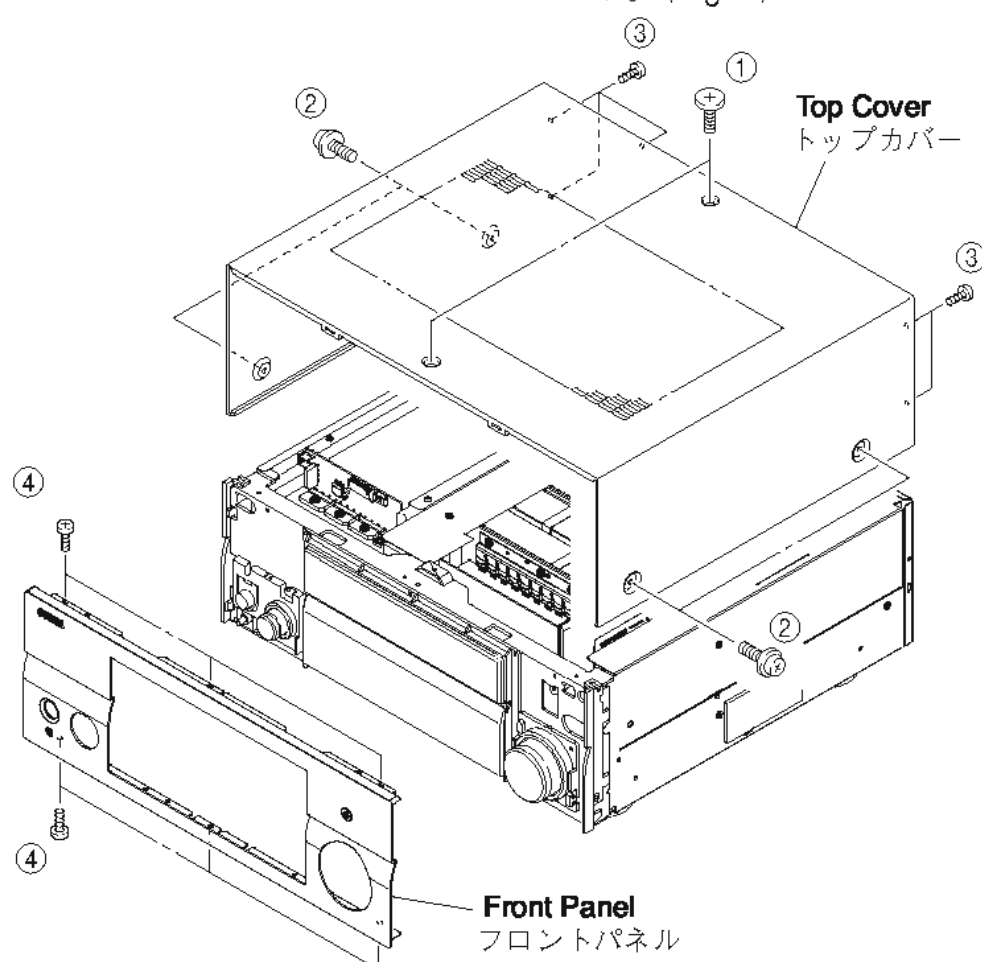

Fig. 1

3. Removal of Sub Chassis

- a. Remove 4 push rivets (⑤) and then remove the Side Plates L/R. (Fig. 2)
- b. Remove 2 screws (⑥), 2 screws (⑦) and 3 screws (⑧). (Fig. 2)
- c. Remove CB2, CB14, CB904 ~ CB907, and CB913. (Fig. 3)
- d. Remove the Sub Chassis forward. (Fig. 2)

3. サブシャーシの外し方

- a. ⑤のプッシュリベット4本を外し、サイドプレートL/Rを取り外します。(Fig. 2)
- b. ⑥のネジ2本、⑦のネジ2本、⑧のネジ3本を外します。(Fig. 2)
- c. CB2、CB14、CB904～CB907、CB913を外します。(Fig. 3)
- d. サブシャーシを前方に取り外します。(Fig. 2)

4. Removal of FUNCTION (1) P.C.B.

- a. Remove 4 screws (⑨) and then remove the Bracket. (Fig. 2)
- b. Remove 1 screw (⑩) and then remove the Support Top. (Fig. 2)
- c. Remove 1 screw (⑪) and 4 screws (⑫). (Fig. 3)
- d. Remove CB301 and CB303 ~ CB306. (Fig. 3)
- e. Remove the FUNCTION (1) P.C.B. which is connected directly to the lower P.C.B. with connectors. (Fig. 2)

4. FUNCTION(1)P.C.B.の外し方

- a. ⑨のネジ4本を外し、ブラケットを取り外します。(Fig. 2)
- b. ⑩のネジ1本を外し、サポートトップを外します。(Fig. 2)
- c. ⑪のネジ1本、⑫のネジ4本を外します。(Fig. 3)
- d. CB301、CB303～CB306を外します。(Fig. 3)
- e. FUNCTION(1)P.C.B.を取り外します。(Fig. 2)
但し、FUNCTION(1)P.C.B.は、下方のP.C.B.と直接コネクタ-接続されています。

- 5. Removal of DSP, FUNCTION (2), INPUT (5), D-VIDEO, A-VIDEO (1), (2) P.C.B.s**
- Remove 2 push rivets (13) and then remove the Duct. (Fig. 2)
 - Remove 1 screw (14). (Fig. 2)
 - Remove 21 screws (15) and 2 jack screws (16). (Fig. 5)
 - Remove CB40, CB44, CB307 (U, C models), CB325, CB332, CB506, CB508, CB602, CB603, CB606, CB608 and CB609. (Fig. 3)
 - Remove the DSP, FUNCTION (2), INPUT (5), D-VIDEO, A-VIDEO (1) and (2) P.C.B.s. (Fig. 4)

- 5. DSP, FUNCTION (2), INPUT (5), D-VIDEO, A-VIDEO (1), (2) P.C.B.の外し方**
- 13のナジユリベツト2本を外し、ダクトを取り外します。(Fig. 2)
 - 14のネジ1本を外します。(Fig. 2)
 - 15のネジ25本、16のジャックスクリュー2本を外します。(Fig. 5)
 - CB40、CB44、CB325、CB332、CB506、CB508、CB602、CB603、CB606、CB608、CB609を外します。(Fig. 3)
 - DSP、FUNCTION(2)、INPUT(5)、D-VIDEO、A-VIDEO(1)、(2) P.C.B.を取り外します。(Fig. 4)

- 6. Removal of INPUT (1) ~ (4) P.C.B.s**
- Remove 14 screws (17). (Fig. 5)
 - Remove CB324. (Fig. 3)
 - Remove the INPUT (1) ~ (4) P.C.B.s. (Fig. 4)

- 6. INPUT (1) ~ (4) P.C.B.の外し方**
- 17のネジ14本を外します。(Fig. 5)
 - CB324を外します。(Fig. 3)
 - INPUT (1) ~ (4) P.C.B.を取り外します。(Fig. 4)

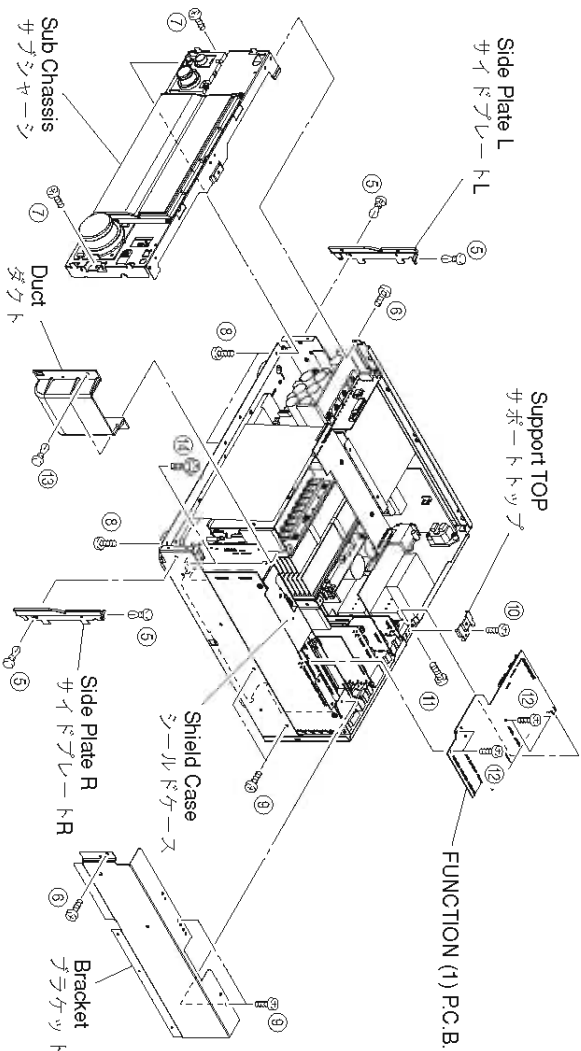

Fig. 2

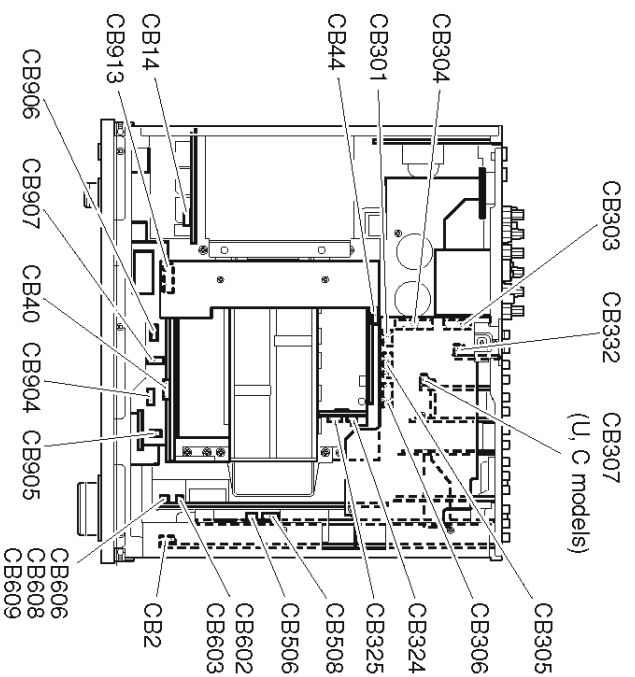

Fig. 3

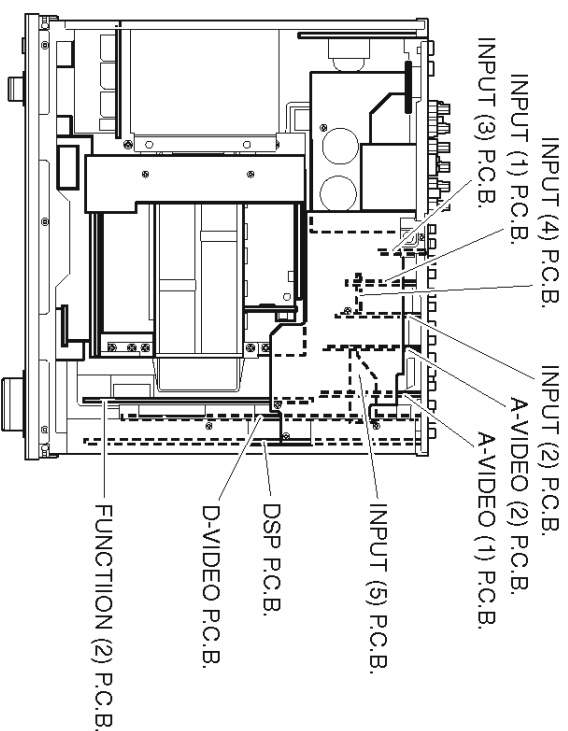
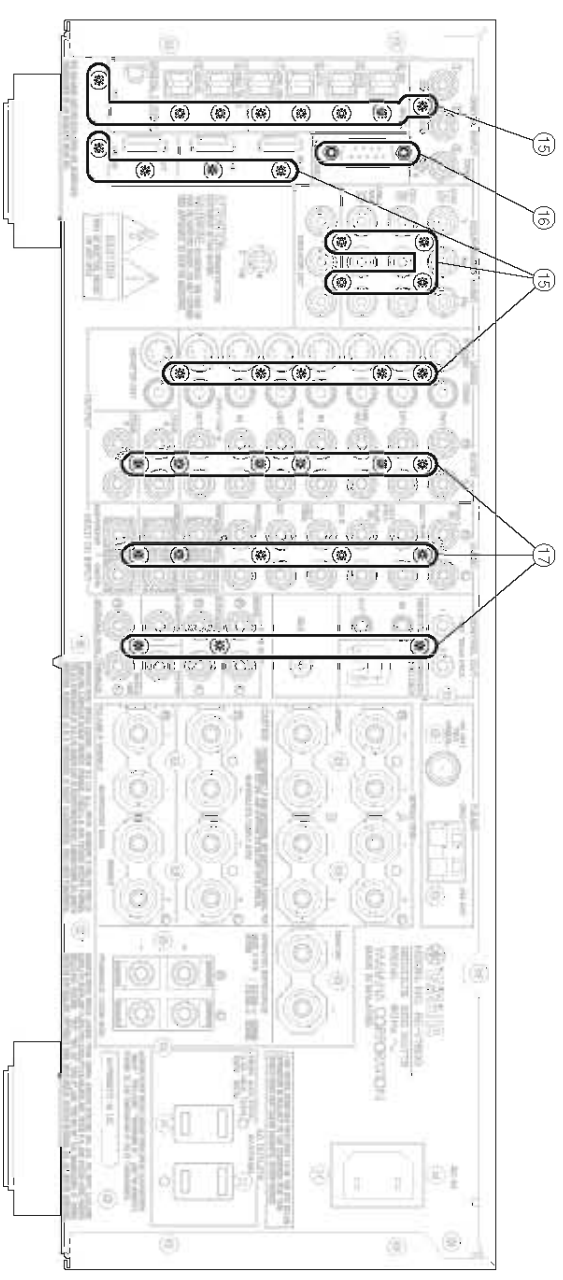
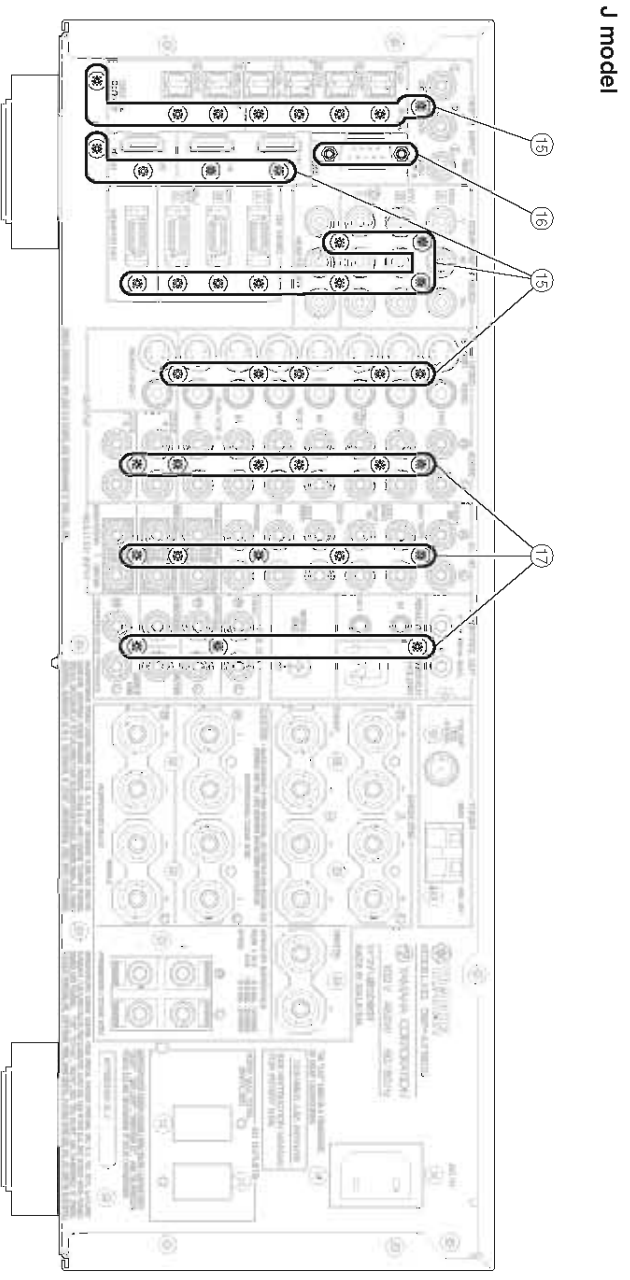

Fig. 4



U, C, R, T, K, A, B, G, L models



J model

Fig. 5

When checking the P.C.B.:

- Put the Rubber Sheet and the Cloth over the equipment. Then place the P.C.B. upside down on the Cloth and check it. (Fig. A)
- Reconnect all cables (connectors) that have been disconnected.

Be sure to use the extension cable for servicing for the following section.

- DSP P.C.B. CB2 – OPERATION (2) P.C.B. CB909:
 - MF117350 (17P 350mm)
 - OPERATION (6) P.C.B. CB912 – FUNCTION (1) P.C.B. CB304:
 - MF131500 (31P 500mm)
 - FUNCTION (1) P.C.B. CB301 – POWER (2) P.C.B. W1:
 - MF408250 (8P 250mm)
 - A-VIDEO (2) P.C.B. W702 – POWER (7) P.C.B. CB325:
 - MF404250 (4P 250mm)
 - When connecting the cable, use care for the polarity.
 - In this unit, the ground of P.C.B.s shown below is connected to the rear panel. When these P.C.B.s are removed from the rear panel, connect the ground to the rear panel or chassis, using a lead wire or the like. (Fig. B)
- | | |
|--------------------|--------------------------|
| DSP P.C.B. | : PJ1 (DIGITAL INPUT) |
| D-VIDEO P.C.B. | : CN301 (HDMI OUT) |
| A-VIDEO (1) P.C.B. | : PJ602 (MONITOR OUT) |
| A-VIDEO (2) P.C.B. | : JK703 (MONITOR OUT) |
| INPUT (1) P.C.B. | : PJ304 (MULTI CH INPUT) |
| INPUT (2) P.C.B. | : PJ307 (ZONE3 OUTPUT) |
| INPUT (3) P.C.B. | : PJ309 (PRE OUT) |

P.C.B.チェックをする場合には

- 本機の上にゴムシートと布を敷き、その上にP.C.B.を裏返しに置いてチェックします。(Fig. A)
- 外したケーブル(コネクタ)をすべて接続します。ただし次の区間は、サービスイテレーションケーブルを使用してください。

DSP P.C.B. CB2 – OPERATION (2) P.C.B. CB909:

- MF117350 (17P 350mm)
 - OPERATION (6) P.C.B. CB912 – FUNCTION (1) P.C.B. CB304:
 - MF131500 (31P 500mm)
 - FUNCTION (1) P.C.B. CB301 – POWER (2) P.C.B. W1:
 - MF408250 (8P 250mm)
 - A-VIDEO (2) P.C.B. W702 – POWER (7) P.C.B. CB325:
 - MF404250 (4P 250mm)
 - ケーブルを接続する際、極性に注意してください。
 - 本機では下記P.C.B.のグランドがリアパネルに接続されています。これらのP.C.B.をリアパネルより取り外した場合は、リード線等でグランドをリアパネルまたはシャーシに接続してください。(Fig. B)
- | | |
|--------------------|--------------------------|
| DSP P.C.B. | : PJ1 (DIGITAL INPUT) |
| D-VIDEO P.C.B. | : CN301 (HDMI OUT) |
| A-VIDEO (1) P.C.B. | : PJ602 (MONITOR OUT) |
| A-VIDEO (2) P.C.B. | : JK703 (MONITOR OUT) |
| INPUT (1) P.C.B. | : PJ304 (MULTI CH INPUT) |
| INPUT (2) P.C.B. | : PJ307 (ZONE3 OUTPUT) |
| INPUT (3) P.C.B. | : PJ309 (PRE OUT) |

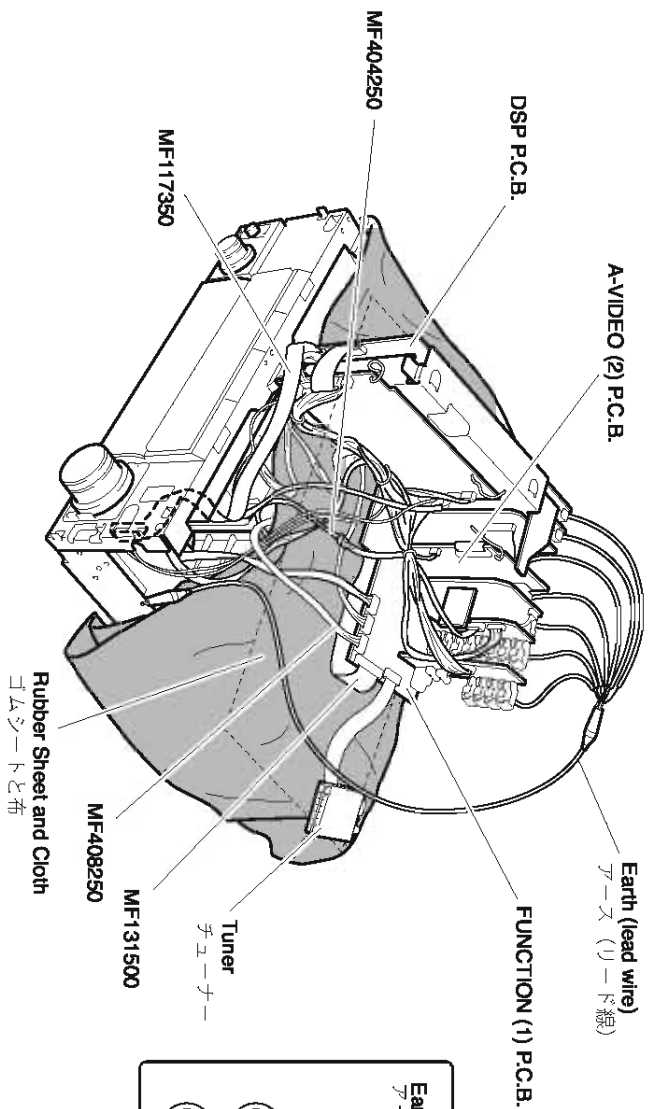

Fig. A

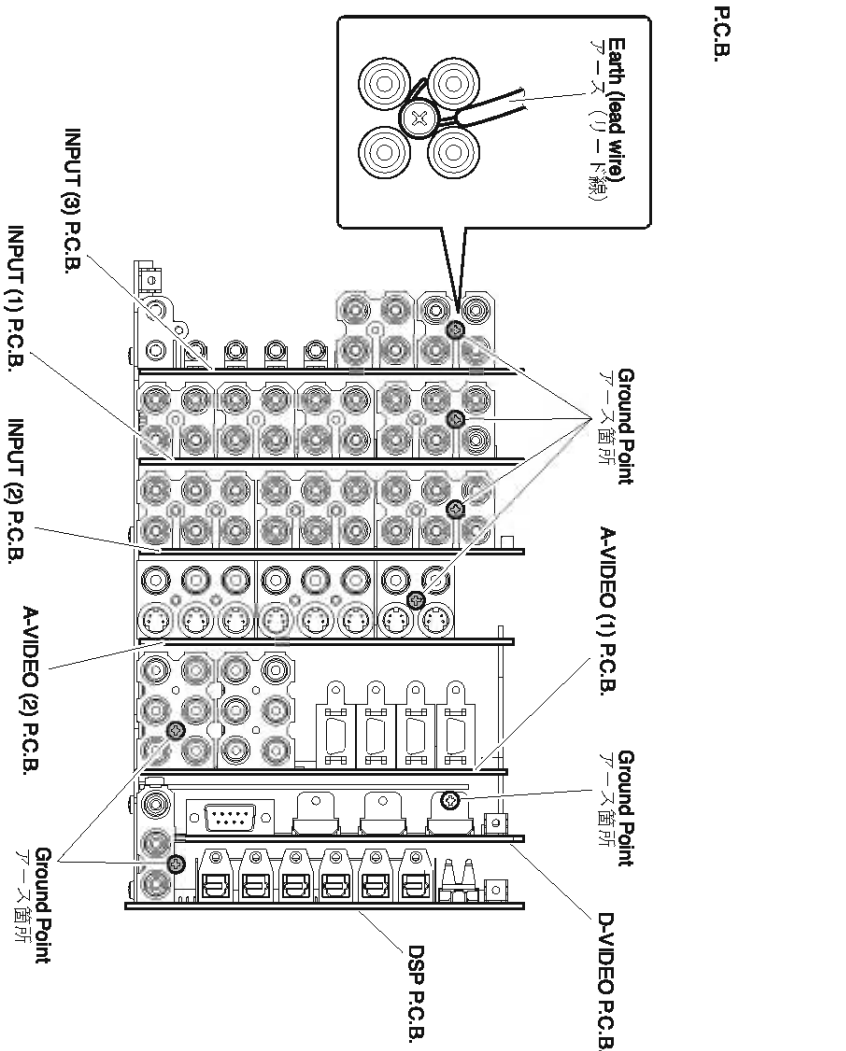

Fig. B

7. Removal of OPERATION (6) P.C.B.

- Remove 2 screws (18). (Fig. 6)
- Remove the OPERATION (6) P.C.B. which is connected directly to the lower P.C.B. with connectors. (Fig. 6)

7. オペレーション(6)P.C.B.の外し方

- ⑱のネジ2本を外します。(Fig. 6)
- OPERATION (6) P.C.B.を取り外します。(Fig. 6) 但し、OPERATION (1) P.C.B.は、下方のP.C.B.と直接コネクタで接続されています。

8. Removal of Fan

- Remove 2 screws (19). (Fig. 6)
- Remove CB20. (Fig. 6)
- Remove the Fan together with the frame by lifting them up. (Fig. 6)

8. ファンを外し方

- ⑲のネジ2本を外します。(Fig. 6)
- CB20を外します。(Fig. 6)
- ファンをフレームとともに上方に取り外します。(Fig. 6)

9. Removal of Amp Unit

- Remove 4 screws (20) and 4 screws (21). (Fig. 6)
- Remove the Amp Unit. (Fig. 6)

9. アンプユニットの外し方

- ⑳のネジ4本、㉑のネジ4本を外します。(Fig. 6)
- アンプユニットを取り外します。(Fig. 6)

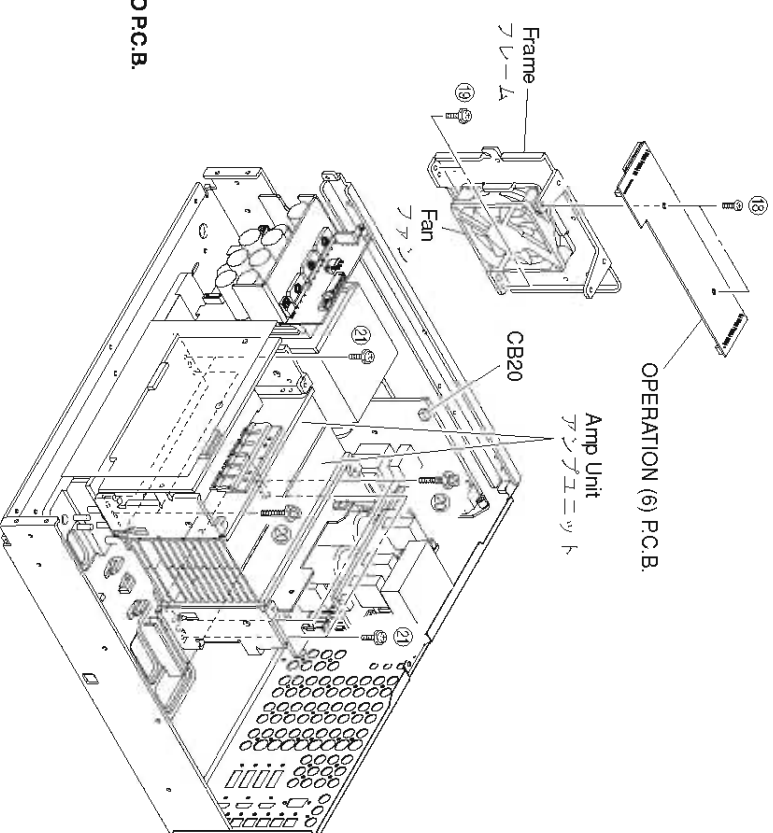

Fig. 6

When checking the Amp Unit:

- The Sub Chassis Unit put on the Rubber Sheet and the Cloth and check it. (Fig. C)
- Reconnect all cables (connectors) that have been disconnected.

Be sure to use the extension cable for servicing for the following section.

DSP P.C.B. CB2 – OPERATION (2) P.C.B. CB909:

MF117350 (17P 350mm)

INPUT (6) P.C.B. CB600 – OPERATION (6) P.C.B. CB913:

MF124500 (24P 500mm)

INPUT (6) P.C.B. W600 – POWER (3) P.C.B. CB14:

MF405400 (5P 400mm)

- When connecting the flat cable, use care for the polarity.

アンプユニットをチェックする場合には

- サブシャーシユニットをゴムシートと布の上に置いてチェックします。(Fig. C)
- 外したケーブル(コネクタ)をすべて接続します。ただし次の区間は、サービス用延長ケーブルを使用してください。

DSP P.C.B. CB2 – OPERATION (2) P.C.B. CB909:
MF117350 (17P 350mm)

INPUT (6) P.C.B. CB600 – OPERATION (6) P.C.B. CB913:
MF124500 (24P 500mm)

INPUT (6) P.C.B. W600 – POWER (3) P.C.B. CB14:
MF405400 (5P 400mm)

- フラットケーブルを接続する際、極性に注意してください。

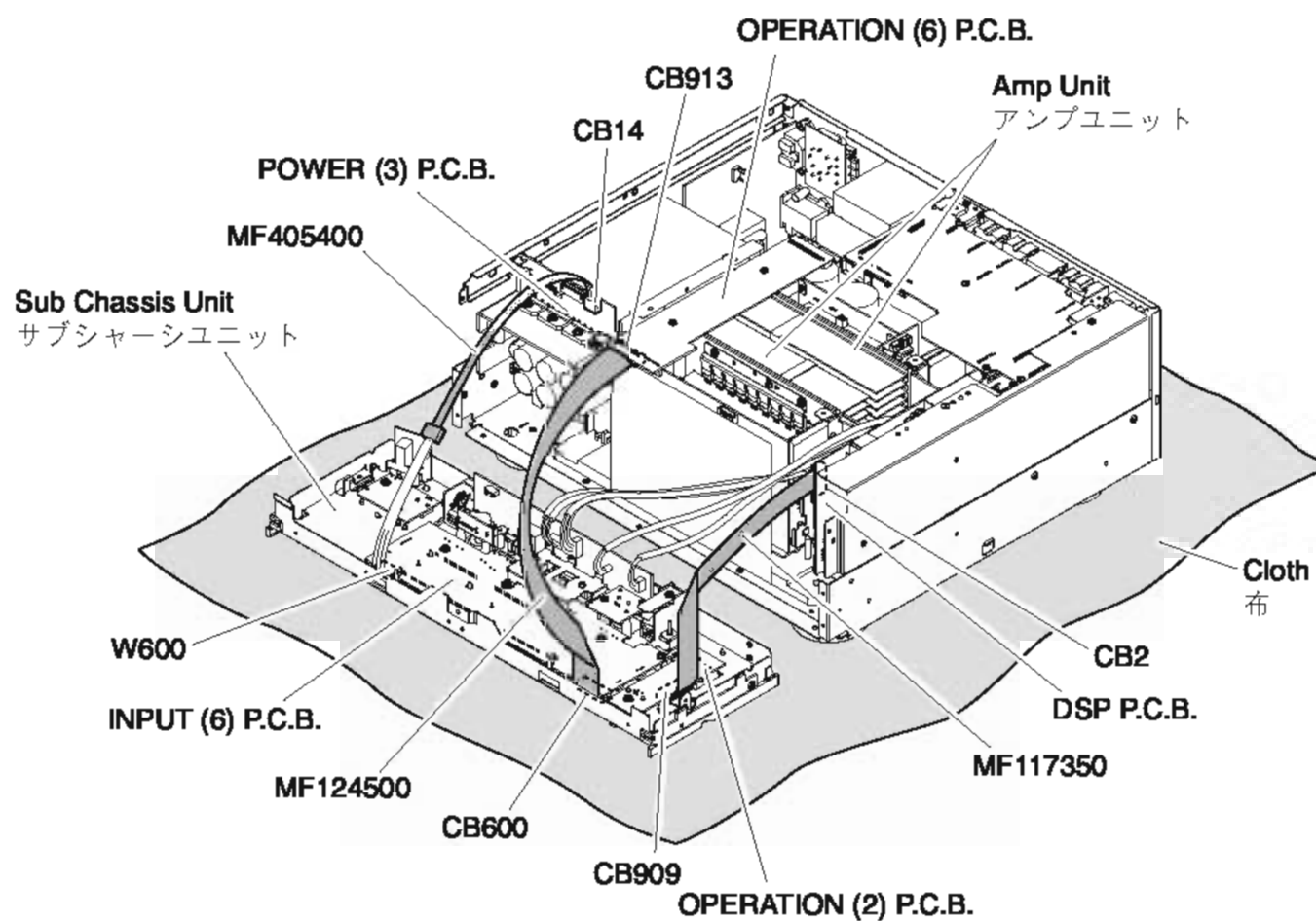

Fig. C

■ UPDATING FIRMWARE / ファームウェアの書き込み

When replacing the following parts, be sure to write the updated data of the firmware.

IC301 of P.C.B. ASS'Y FUNCTION : X6909A00
... Writing of MAIN
IC507 of P.C.B. ASS'Y D-VIDEO : X7220A00
... Writing of VIDEO
IC542 of P.C.B. ASS'Y DSP : X7016A00
... Writing of DSP

● Required tools

- DOS/V machine, OS: Windows 98/2000/Me/XP, PC with a serial port (RS232C)
- Program upgrading program
DSP_FLASHER_Vx600.exe
- Firmware
 - * Be sure to put following 3 firmwares in the same folder.
 - MAIN V16Mxxxx.mot
 - VIDEO V16Vxxxx.mot
 - DSP Vx600_verX_XX_0xXXXXXXXXX.hex

- RS232C cross cable "D-sub 9 pin female"
(Specifications)

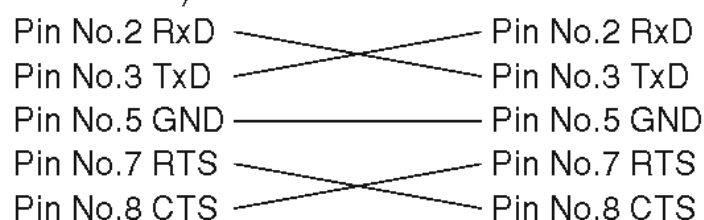

● Preparation and precautions before starting the operation

- Download DSP_FLASHER_Vx600.exe from the specified source to the PC being used.
- Prepare the above specified RS232C cross cable.
- While writing, keep the other application software on the PC closed. It is also recommended to keep the software on the task tray closed as well.

下記の部品をサービス部品に交換した場合、最新のファームウェアの書き込みを行ってください。

P.C.B. FUNCTIONのIC301 : X6909A00
... MAINの書き込み
P.C.B. D-VIDEOのIC507 : X7220A00
... VIDEOの書き込み
P.C.B. DSPのIC542 : X7016A00
... DSPの書き込み

● 必要なツール

- DOS/V機、OS：Windows 98/2000/Me/XP、シリアルポート付き (RS232C) PC
- プログラムアップグレードプログラム
DSP_FLASHER_Vx600.exe
- ファームウェア
 - ※ 以下の3つのファームウェアは必ず同一フォルダ内へ入れてください。
 - MAIN V16Mxxxx.mot
 - VIDEO V16Vxxxx.mot
 - DSP Vx600_verX_XX_0xXXXXXXXXX.hex

- RS232Cクロスケーブル "D-sub 9pin メス"
(仕様)

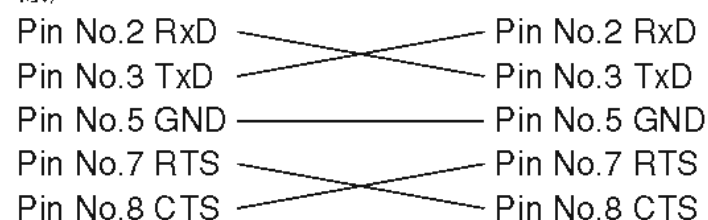

● 操作前の準備と注意

- PCへ指定のダウンロード先から DSP_FLASHER_Vx600.exeをダウンロードしてください。
- RS232Cクロスケーブルは必ず上記仕様のもを用意してください。
- 書き込み時は、PC上の他のアプリケーションソフトは閉じてください。さらに、タスクトレイ上にあるソフトも閉じておくことを推奨します。

● Operation Procedure

● 操作方法

Writing of MAIN or VIDEO

MAINまたは、VIDEOの書き込み

1. Install DSP_FLASHER_Vx600.exe into the PC.
2. Connect the RS232C terminal of the main unit to the PC's RS232C terminal with the RS232C cross cable. (Fig. 1)

1. PCにDSP_FLASHER_Vx600.exeをインストールします。
2. 本機のRS232C端子とPCのRS232C端子をRS232Cクロスケーブルで接続します。(Fig. 1)

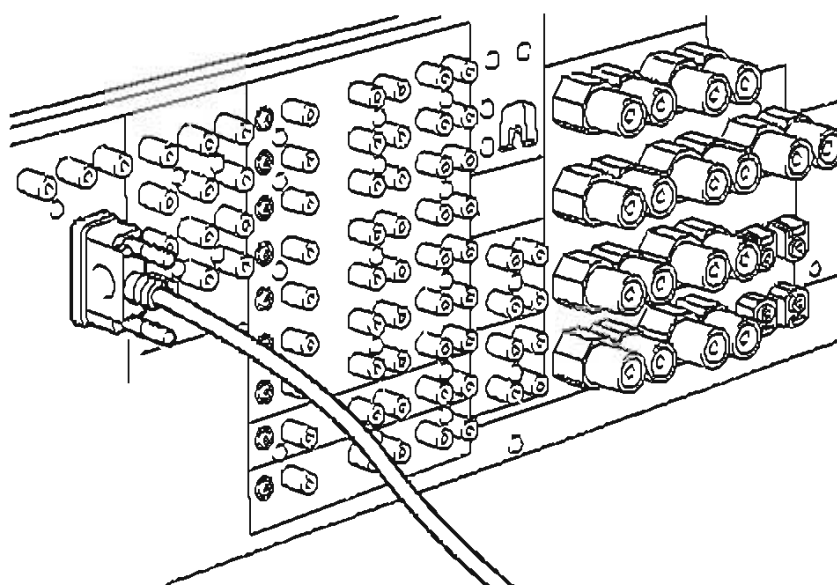
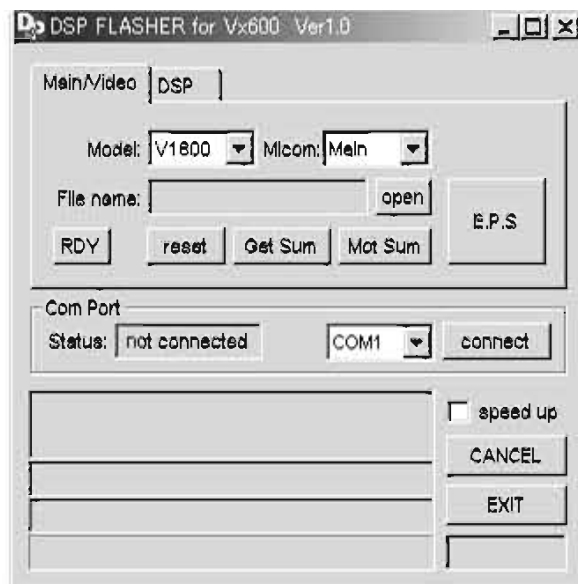

Fig. 1

3. Start up DSP_FLASHER_Vx600.exe. Then the screen shown below is displayed.

3. PCのDSP_FLASHER_Vx600.exeを立ち上げます。すると下記の画面が表示されます。



RX-V1600/DSP-AX1600

4. Select the model name of the receiver, the Micom, Com Port and file name.
 - **Model**
Select "V1600".
 - **Micom**
Writing of MAIN : Select "Main".
Writing of VIDEO : Select "Video"
 - **Com Port**
Select the port of RS-232C to use and press the [connect] button.
(Com Port Status changes to "connected")
 - **File name**
Writing of MAIN : Select "V16Mxxxx.mot".
Writing of VIDEO : Select "V16Vxxxx.mot"

4. レシーバのモデル名、マイコン、ポート、ファイル名を選択します。
 - **Model**
"V1600"を選択します。
 - **Micom**
MAINの書き込み時 : "Main"を選択します。
VIDEOの書き込み時 : "Video"を選択します。
 - **Com Port**
接続しているRS-232Cポートを選択し[connect]ボタンを押します。
(Com Port Statusが"connected"に変わります)
 - **File name**
MAINの書き込み時 : "V16Mxxxx.mot"を選択します。
VIDEOの書き込み時 : "V16Vxxxx.mot"を選択します。

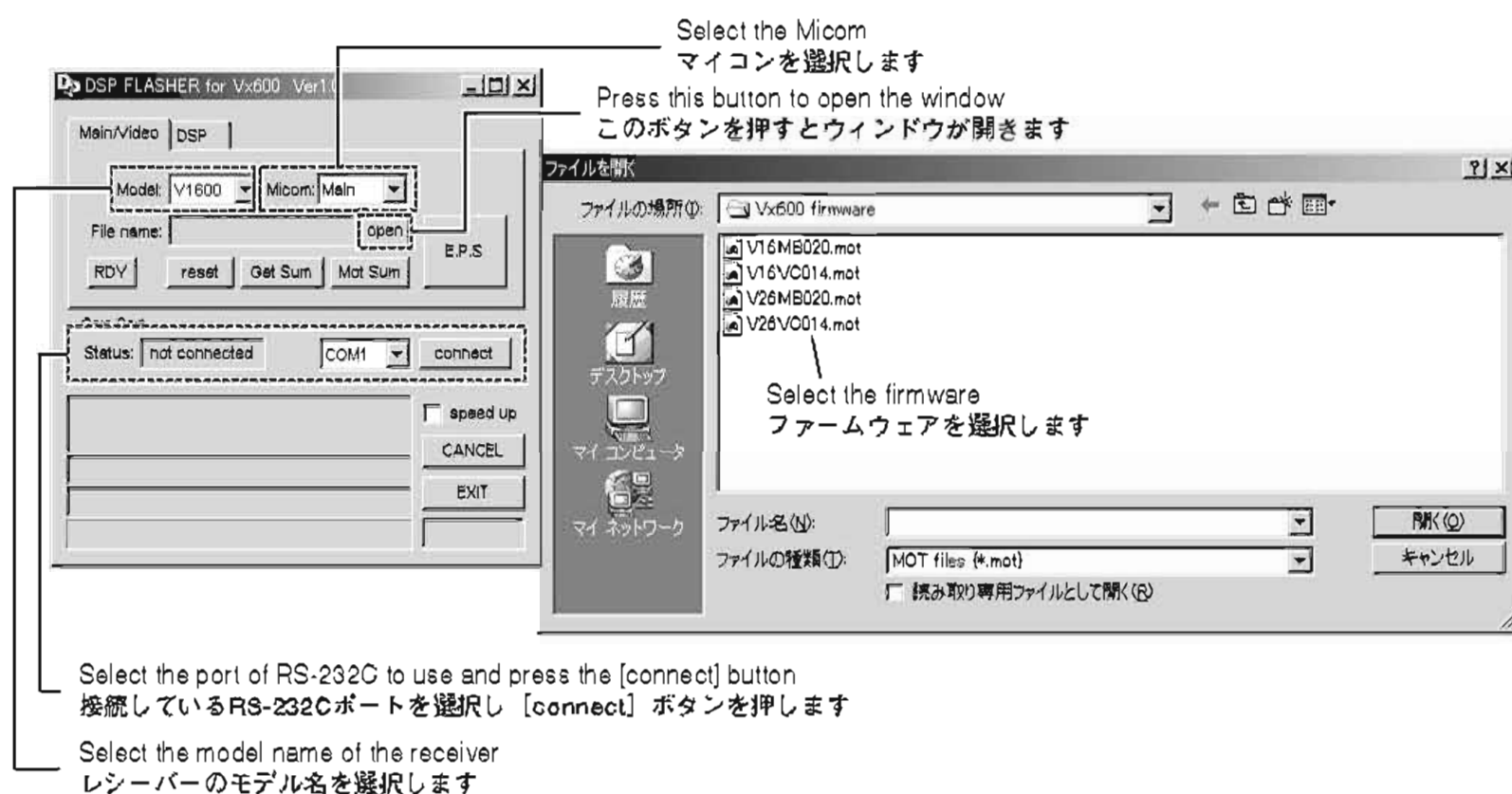

5. Connect the power cable of main unit to the AC outlet. While pressing the "PRESET/TUNING ▶" key and "A/B/C/D/E" key of the main unit, press the "MASTER ON/OFF" key to activate the DIAG function.
 - a. Using the "PROGRAM" knob of the main unit, select the DIAG menu in the figure below.

24. FLASH 232C
MAIN

5. 本機の電源コードをACコンセントに接続し、本機の"PRESET/TUNING ▶"キーと"A/B/C/D/E"キーを押しながら、"MASTER ON/OFF"キーを押し、ダイアグを起動します。
 - a. 本機の"PROGRAM"ノブを回し、下図のダイアグメニューを選択します。

- b. Using the "PRESET/TUNING ▶" key of the main unit, select the DIAG sub-menu in the figure below.
 - Writing of MAIN / MAINの書き込み

24. FLASH 232C
MAIN

- b. 本機の"PRESET/TUNING ▶"キーを使い、下図のダイアグメニューを選択します。

- Writing of VIDEO / VIDEOの書き込み

24. FLASH 232C
VIDEO

6. Press the [RDY] button.

6. [RDY]ボタンを押します。

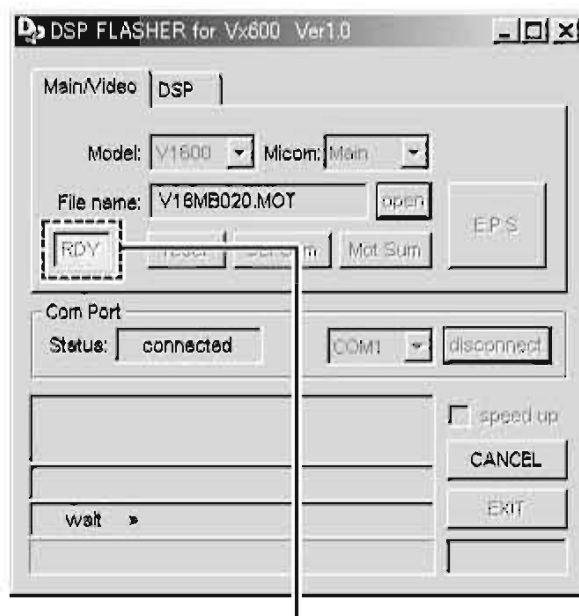

Press this button
このボタンを押します

7. Press the "STRAIGHT" key of the main unit.

7. 本機の"STRAIGHT"キーを押します。

8. Press the [E.P.S.] button and start writing.

8. [E.P.S.]ボタンを押し、書き込みを開始します。

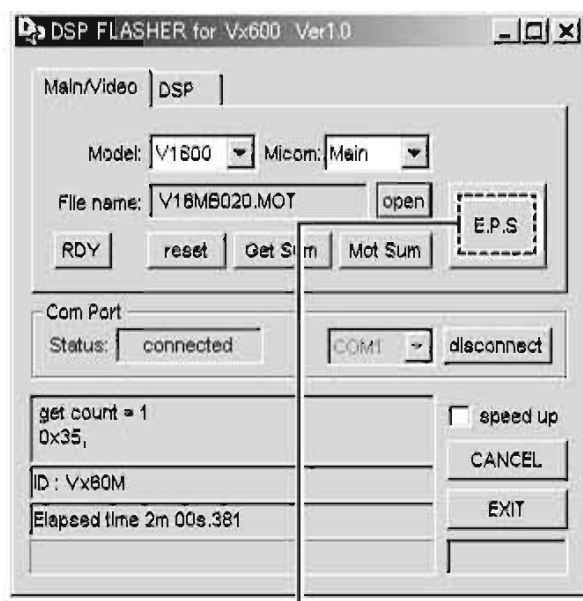

Press this button
このボタンを押します

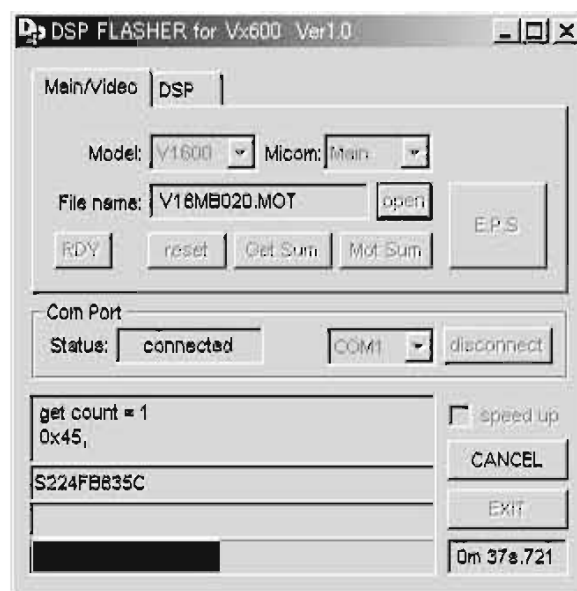

During downloading
書き込み中

RX-V1600/DSP-AX1600

9. Check the checksum.

When writing is completed, the checksum is displayed in the box located at the lower left of "CheckSum result".

- a. Disconnect the power cable of main unit from the AC outlet.
- b. Connect the power cable of main unit to the AC outlet. Start the DIAG function of the main unit and check that the checksum value is the same.

The procedure is completed when the same version as shown below is obtained.

9. チェックサムを確認します。

書き込みが完了後、“CheckSum result”の左下BOXにチェックサムが表示されます。

- a. 本機の電源コードをACコンセントから抜きます。
- b. 本機の電源コードをACコンセントに接続し、本体のダイアグを起動してチェックサム値が同じであることを確認します。

以下のように同様のバージョンになれば完了です。

Check that the checksum value is the same
チェックサム値が同じであることを確認します

* If there is a difference, perform the procedure again starting from step "3.Start up DSP_FLASHER_Vx600.exe".

※ チェックサムの値が違っている場合は、“3.DSP_FLASHER_Vx600.exeを立ち上げ”からやり直してください。

Writing of DSP

1. Install DSP_FLASHER_Vx600.exe into the PC.
2. Connect the RS232C terminal of the main unit to the PC's RS232C terminal with the RS232C cross cable. (Fig. 1)
3. Start up DSP_FLASHER_Vx600.exe. Then the screen shown below is displayed.

DSPの書き込み

1. PCにDSP_FLASHER_Vx600.exeをインストールします。
2. 本機のRS232C端子とPCのRS232C端子をRS232Cクロスケーブルで接続します。(Fig. 1)
3. PCのDSP_FLASHER_Vx600.exeを立ち上げます。すると下記の画面が表示されます。

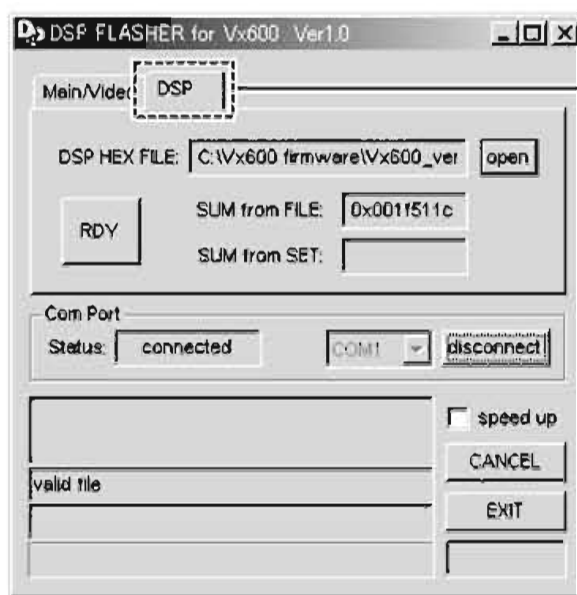

Select DSP
DSPを選択します

4. Select "DSP" Tag.
5. Select the data to be transmitted and Com Port.
 - **DSP HEX FILE**
Select "Vx600_verX_XX_0XXXXXXXXX.hex".
 - **Com Port**
Select the port of RS-232C to use and press the [connect] button. (Com Port Status changes to "connected")

4. "DSP"タグを選択します。
5. 送信データ、ポートを選択します。
 - **DSP HEX FILE**
"Vx600_verX_XX_0XXXXXXXXX.hex"を選択します。
 - **Com Port**
接続しているRS-232Cポートを選択し [connect] ボタンを押します。 (Com Port Statusが"connected"に変わります)



Select the port of RS-232C to use and press the [connect] button
接続しているRS-232Cポートを選択し [connect] ボタンを押します

RX-V1600/DSP-AX1600

6. Connect the power cable of main unit to the AC outlet. While pressing the “PRESET/TUNING ▶” key and “A/B/C/D/E” key of the main unit, press the “MASTER ON/OFF” key to activate the DIAG function.
- a. Using the “PROGRAM” knob of the main unit, select the DIAG menu in the figure below.



- b. Using the “PRESET/TUNING ▶” key of the main unit, select the DIAG sub-menu in the figure below.



7. Press the [RDY] button.

6. 本機の電源コードをACコンセントに接続し、本体の“PRESET/TUNING ▶”キーと“A/B/C/D/E”キーを押しながら、“MASTER ON/OFF”キーを押し、ダイアグを起動します。
- a. 本機の“PROGRAM”ノブを回し、下図のダイアグメニューを選択します。

- b. 本機の“PRESET/TUNING ▶”キーを使い、下図のダイアグメニューを選択します。

7. [RDY]ボタンを押します。

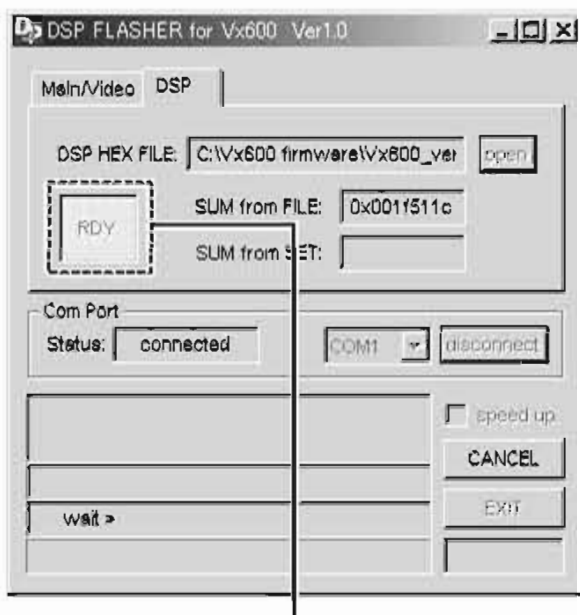

Press this button
このボタンを押します

8. Press the “STRAIGHT” key of the main unit. The writing function starts.

8. 本機の“STRAIGHT”キーを押します。書き込みを開始します。

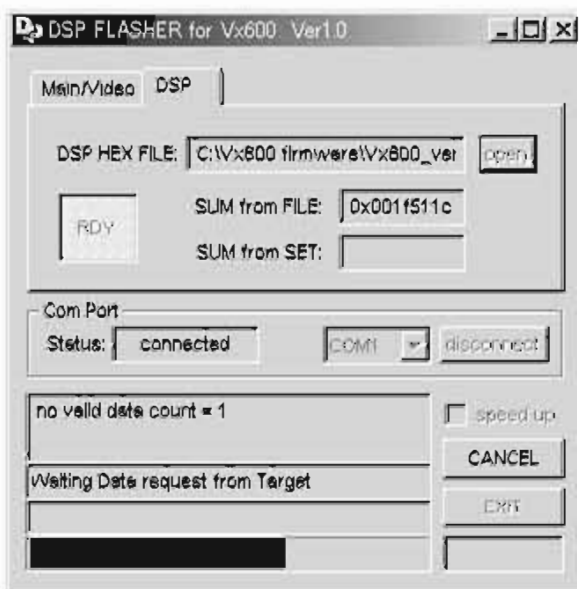

During downloading
書き込み中

* When writing is completed, the power to the main unit is automatically turned OFF/ON.

※ 書き込みが完了すると本体は自動的に電源OFF/ONします。

9. Check the checksum.
After downloading successfully, the value of "SUM from SET" is displayed.

Start the DIAG function of the main unit and check that the checksum value is the same.

The procedure is completed when the same version as shown below is obtained

9. チェックサムを確認します。
書き込み完了後、“SUM from SET”が表示されます。

本機のダイアグを起動しチェックサムの値が同じであることを確認します。

以下のように同様のバージョンになれば完了です。

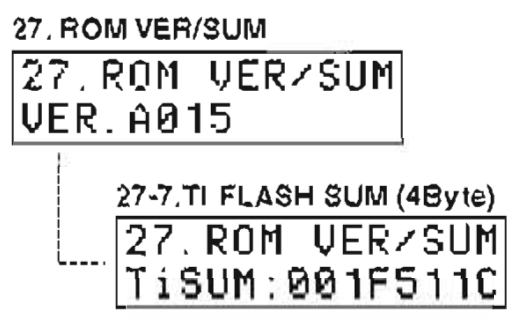
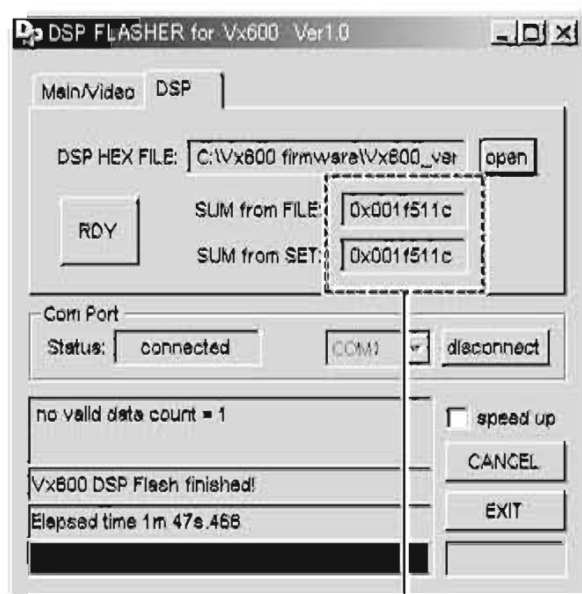

Check that the checksum value is the same
チェックサム値が同じであることを確認します

- If there is a difference, perform the procedure again starting from step "3.Start up DSP_FLASHER_Vx600.exe".

※ チェックサムの値が違っている場合は、“3.DSP_FLASHER_Vx600.exeを立ち上げ”からやり直してください。

■ SELF DIAGNOSIS FUNCTION (DIAG) / 自己診断機能 (ダイアグ)

There are 27 DIAG menu items, each of which has sub-menu items. Listed in the table below are menu items and sub-menu items.

ダイアグメニューは27個あり、そのそれぞれにサブメニューがあります。下表はメニュー一覧です。

No	DIAG MENU	SUB MENU
1	DA60Y-YSS930 1. DA60Y-YSS930 MARGIN	1. MARGIN
		2. FULL BIT
2	BYPASS 2. BYPASS ANALOG BYPASS	1. ANALOG BYPASS
		2. DSP BYPASS
3	RAM THROUGH 3. RAM THROUGH MARGIN	1. MARGIN
		2. FULL BIT
4	HDMI AUDIO 4. SPDIF	1. SPDIF
		2. Multi
		3. DSD (Not applied to this model. / このモデルには適用されません。)
		4. DSD DIRECT (Not applied to this model. / このモデルには適用されません。)
5	SPEAKERS SET 5. SPEAKERS SET FRONT: SML 0dB	1. FRONT: SMALL 0dB
		2. CENTER: NONE
		3. LFE/B: FRNT
		4. Pres Mix: 5ch
		5. FATT1 GAIN
		6. FATT2 GAIN
		7. Surr B: MUTE
		8. Surr L/R: MUTE
		9. Surr NONE
		10. ZoneOn Zone Amp Tone: MAX
		11. ZoneOn Zone Amp Tone: MIN
6	Multi INPUT 6. Multi INPUT 6ch INPUT_6Ω	1. 6ch INPUT_6 ohms
		2. 8ch INPUT_6 ohms
		3. 6ch INPUT_8 ohms
		4. 8ch INPUT_8 ohms
		5. TMP TEST
7	MIC CHECK 7. MIC CHECK --- db	1. MIC CHECK
8	STRAIGHT DISPLAY CHECK 8. STRAIGHT DISPLAY CHECK	1. STRAIGHT (Initial display / 初期表示)
		2. VFD DISP OFF (All segments OFF / 全セグメント消灯)
		3. VFD DISP ALL (All segments ON 100% / 全セグメント点灯100%)
		4. VFD DIMMER (All segments ON 50% / 全セグメント点灯50%)
		5. CHECK PATTERN (ON in lattice / 格子状点灯)
9	MANUAL TEST 9. MANUAL TEST TEST ALL	1. TEST ALL
		2. TEST FRNT L
		3. TEST CENTER
		4. TEST FRNT R
		5. TEST SURR R
		6. TEST SB R
		7. TEST SB L
		8. TEST SURR L
		9. TEST PRES L
		10. TEST PRES R
		11. TEST LFE
10	RS-232C 10. RS-232C TX DATA: NG	1. TX DATA
		2. HARD FLOW
11	FACTORY PRESET 11. FAC PRESET PRESET INH	1. PRESET INH (memory initialization inhibited / メモリーの初期化禁止)
		2. PRESET RSRV (memory initialized / メモリーの初期化)
12	AD DATA CHECK 12. AD CHECK DC: 021	1. DC
		2. PS1/PS2

No	DIAG MENU	SUB MENU
13	XM STATUS [13. XM STATUS 1k - 1dB/44	3. TM1/TM2 4. RECOUT SEL (Not applied to this model. / このモデルには適用されません。) 5. POWER LIMITER 6. LIMIT 7. FAN 8. MODEL 9. DESTINATION 10. PANEL KEY (K0/K1) 1. 1k -1dB /44. 1k 2. 1k -61dB /44. 1k 3. Mute /44. 1k 4. XM Tone /44. 1k 5. ISO Tone /44. 1k 6. 1k -1dB /32k 7. 1k -61dB /32k 8. Mute /32k 9. XM Tone /32k 10. ISO Tone /32k 11. XM/DT Bus Power: OFF
14	IF STATUS [14. IF STATUS 151: 3300020000	1. IS 1 (5Byte) 2. IS 2 (2Byte) 3. CS 1 (5Byte) 4. CS 2 (5Byte) 5. CS 3 (4Byte) 6. BS 1 (2Word) 7. BS 2 (2Word) 8. BS 3 (2Word) 9. BS 4 (2Word) 10. BS 5 (2Word) 11. BS 6 (2Word) 12. BS 7 (2Word) 13. BS 8 (2Word) 14. BS 9 (2Word) 15. BS 10 (2Word) 16. TI 1 (5Byte) 17. TI 2 (1Byte) 18. MITT (5Byte)
15	PROTECTION SETTING (Not applied to this model. / このモデルには適用されません。) [15. PROTECTION PS_Lo: 0076	1. PS_Lo 2. PS_HI 3. DC_Lo 4. DC_HI 5. FUN_0 6. FUN_1 7. FUN_2 8. FUN_3 9. FUN_4 10. FUN_5 11. TEMP 12. PL_8_M_L 13. PL_8_M_H 14. PL_8_N_L 15. PL_8_N_H 16. PL_6_M_L 17. PL_6_M_H 18. PL_6_N_L 19. PL_6_N_H

No	DIAG MENU	SUB MENU
16	PROTECTION HIST. [16. PROTE HIST. HIST:	1. LAST: 2. HIST1: 3. HIST2: 4. HIST3:
17	DSP CHECK [17. DSP CHECK TI BUS: NOER	1. TI BUS 2. YSS-930 BUS 1. ALL Check 2. Micom/Flash Check 3. I2C Read Check 4. YGV Bus Check (Not applied to this model. / このモデルには適用されません。) 1. HDMI Model Name 2. HDMI Product ID 3. HDMI Vendor Name 1. HDMI NONE: No Connect 2. HDMI IN 1: HDMI IN 1 Port 3. HDMI IN 2: HDMI IN 2 Port
18	D-VIDEO CHK [18. DVIDEO CHK ALL: OK	1. ALL Check 2. Micom/Flash Check 3. I2C Read Check 4. YGV Bus Check (Not applied to this model. / このモデルには適用されません。) 1. HDMI Model Name 2. HDMI Product ID 3. HDMI Vendor Name 1. HDMI NONE: No Connect 2. HDMI IN 1: HDMI IN 1 Port 3. HDMI IN 2: HDMI IN 2 Port
19	HDMI INFO [19. HDMI INFO HMN: DSP-AX1600	1. HDMI Model Name 2. HDMI Product ID 3. HDMI Vendor Name 1. HDMI NONE: No Connect 2. HDMI IN 1: HDMI IN 1 Port 3. HDMI IN 2: HDMI IN 2 Port
20	HDMI SELECT [20. HDMI SELECT HDMI NONE	1. HDMI NONE: No Connect 2. HDMI IN 1: HDMI IN 1 Port 3. HDMI IN 2: HDMI IN 2 Port
21	HDMI UPCONV [21. HDMI UPCONV HDMI DECODER	1. HDMI Decoder (Not applied to this model. / このモデルには適用されません。) 2. HDMI YGV (Not applied to this model. / このモデルには適用されません。) 3. HDMI I/P 4. HDMI 720p (Not applied to this model. / このモデルには適用されません。) 5. HDMI 1080i (Not applied to this model. / このモデルには適用されません。) 1. DIGITAL THR COMP 2. DIGITAL THR CVBS 3. DIGITAL THR Y/C 4. DIGITAL BYPASS 5. ANALOG BYPASS 6. TEST PATTERN 1 7. TEST PATTERN 2 8. VIDEO INFO 1. TI FLASH READ 2. TI FLASH WRITE 3. TI SDRAM READ 4. TI SDRAM WRITE 5. YGV READ 6. YGV WRITE 1. MAIN 2. VIDEO 3. TI
22	VIDEO [22. VIDEO DIGITAL COMP	1. DIGITAL THR COMP 2. DIGITAL THR CVBS 3. DIGITAL THR Y/C 4. DIGITAL BYPASS 5. ANALOG BYPASS 6. TEST PATTERN 1 7. TEST PATTERN 2 8. VIDEO INFO 1. TI FLASH READ 2. TI FLASH WRITE 3. TI SDRAM READ 4. TI SDRAM WRITE 5. YGV READ 6. YGV WRITE 1. MAIN 2. VIDEO 3. TI
23	BUS CHECK (Not applied to this model. / このモデルには適用されません。) [23. BUS CHECK TI FLASH R	1. TI FLASH READ 2. TI FLASH WRITE 3. TI SDRAM READ 4. TI SDRAM WRITE 5. YGV READ 6. YGV WRITE 1. MAIN 2. VIDEO 3. TI
24	FLASH 232C [24. FLASH 232C MAIN	1. MAIN 2. VIDEO 3. TI
25	SET INFO [25. SET INFO MODEL: V1600	1. MODEL: V1600 2. DEST.: J, UC, R, T, K, A, BG, L 1. SW MODE: PCB/FNC 2. VIDEO FORMAT: NTSC/PAL 3. AAC EXIST: EXIST/NOT 4. CSII EXIST: EXIST/NOT 5. RDS EXIST: EXIST/NOT 6. XM EXIST: EXIST/NOT 7. TMP TEST JUC/RL 8. TMP TEST UCKTABG 9. TMP TEST RL 1. MAIN VERSION 2. MAIN SUM 3. VIDEO VERSION 4. VIDEO SUM 1 5. VIDEO SUM 2 6. TI FLASH VERSION 7. TI FLASH SUM (4Byte) 8. XM VERSION
26	SOFT SW [26. SOFT SW SM MODE: PCB	1. SW MODE: PCB/FNC 2. VIDEO FORMAT: NTSC/PAL 3. AAC EXIST: EXIST/NOT 4. CSII EXIST: EXIST/NOT 5. RDS EXIST: EXIST/NOT 6. XM EXIST: EXIST/NOT 7. TMP TEST JUC/RL 8. TMP TEST UCKTABG 9. TMP TEST RL 1. MAIN VERSION 2. MAIN SUM 3. VIDEO VERSION 4. VIDEO SUM 1 5. VIDEO SUM 2 6. TI FLASH VERSION 7. TI FLASH SUM (4Byte) 8. XM VERSION
27	ROM VER/SUM [27. ROM VER/SUM VER: H015	1. MAIN VERSION 2. MAIN SUM 3. VIDEO VERSION 4. VIDEO SUM 1 5. VIDEO SUM 2 6. TI FLASH VERSION 7. TI FLASH SUM (4Byte) 8. XM VERSION

● **Starting DIAG**

Press the "MASTER ON/OFF" key while simultaneously pressing those two keys of the main unit as indicated in the figure below.

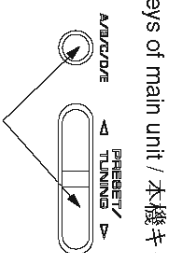

Turn on the power while pressing these keys.
これらのキーを同時に押しながら、パワーオンする。

● **Starting DIAG in the protection cancel mode**

If the protection function works and causes hindrance to trouble diagnosis, cancel the protection function as described below, and it will be possible to enter the DIAG mode. (The protection functions other than the excess current detect function will be disabled.)

Press the "MASTER ON/OFF" key while simultaneously pressing those two keys indicated in the figure above. At this time, keep pressing those two keys for 3 seconds or longer.

In this mode, the "SLEEP" segment of the FL display of the main unit flashes to indicate that the mode is DIAG mode with the protection functions disabled.

CAUTION!
Using this product with the protection function disabled may cause damage to itself. Use special care for this point when using this mode.

● **Canceling DIAG**

- ① Before canceling DIAG, execute setting for PRESET of DIAG menu No.11 (Memory initialization inhibited or Memory initialized).
* In order to keep the user memory stored, be sure to select PRESET INHIBIT (Memory initialization inhibited). Any protection history will remain in memory.
- ② Turn off the power by pressing the "MASTER ON/OFF" key of the main unit or the "STANDBY" key of the remote control.

● **ダイアグの起動**

本機の下図に示すキーを同時に押しながら“MASTER ON/OFF”キーを押すと、ダイアグが起動します。

● **プロテクション解除モードでの起動**

プロテクションが動作することにより、故障箇所の診断に支障をきたすような場合は、次の方法によりプロテクションを解除した状態でダイアグモードに入ることが出来ます。(過電流検出以外のプロテクション動作を解除する)

上図のキーを同時に押しながら“MASTER ON/OFF”キーを押します。このとき、上図のキーを3秒以上押し続けてください。

このモードでは本機FLの“SLEEP”セグメントが点滅し、プロテクションを解除した状態でのダイアグモードであることを知らせます。

注意!
プロテクションを解除した状態でのダイアグモードは、危険な状態でもプロテクションが動作しないため、動作させると、機器を破壊することがあります。このモードを使用する場合は十分注意してください。

● **ダイアグの解除**

- ① ダイアグを解除する前に、ダイアグメニューNo.11のFACTORY PRESET (メモリーの初期化禁止/またはメモリーの初期化)の設定をします。
※ ユーザーメモリーを保持したい場合は、必ずPRESET INHIBIT (メモリー初期化禁止)を選択してください。
- ② 本機の“MASTER ON/OFF”キーかリモコンの“STANDBY”キーを押し、パワーオフにします。

● **Display provided when DIAG started**

The FL display of the main unit displays the protection function history data and the version (1 alphabet) and the DIAG menu (sub-menu MARGIN of DIAG menu No.1 DA60Y-YSS930) a few seconds later.

● **ダイアグ起動時の表示**

本機のFLディスプレイにプロテクション履歴情報とバージョン(英1文字)が表示され、数秒後にダイアグメニュー(No.1 DA60Y-YSS930のサブメニューMARGIN)になります。

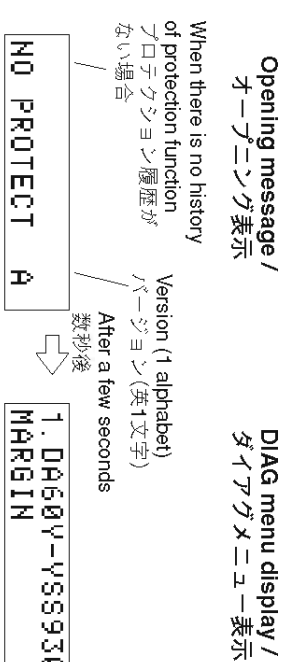

When there is no history of protection function:

プロテクション履歴がない場合:

When there is a history of protection function:

プロテクション履歴がある場合:

Cause: An excessive current flowed through the power amplifier.
Turning on the power without correcting the abnormality will cause the protection function to work immediately and the power supply will instantly be shut off.

原因: パワーアンプに過電流が流れた。
補足: パワーアンプの電流を検出していきますので、電流検出トランジスタをチェックすれば異常チャネルが特定できます。
異常状態のままパワーオンすると、瞬時にプロテクションがかかり、すぐに電源が切れます。

Note)

- Applying the power to a unit without correcting the abnormality can be dangerous and cause additional circuit damage.
- The output transistors in each amplifier channel should be checked for damage before applying any power.
- Amplifier current should be monitored by measuring across the emitter resistors for each channel.

When there is a history of protection
function due to abnormal voltage in
the power supply section
電源部の電圧異常によるプロテク
ション履歴がある場合 \

Version (1 alphabet)
バージョン(英1文字)

PSx PRT:000 A

A/D conversion value of voltage
電圧のA/D変換値

Cause: The voltage in the power supply section is abnormal.

Supplementary information: The abnormal voltage is displayed in based on 5V as 255.

Turning on the power without correcting the abnormality will cause the protection function to work 1 second later and the power supply will be shut off.

原因: 電源部の電圧が異常。

補足: 異常時の電圧の状態を、5Vを255とした値で表示します。

異常状態のままパワーオンすると、1秒後にプロテクションがかかり、電源が切れます。

When there is a history of protection
function due to abnormal DC output
DC出力異常によるプロテクション
履歴がある場合 \

Version (1 alphabet)
バージョン(英1文字)

DC PRT:000 A

A/D conversion value of voltage
電圧のA/D変換値

Cause: DC output of the power amplifier is abnormal.

Supplementary information: The abnormal voltage is displayed in based on 5V as 255.

Turning on the power without correcting the abnormality will cause the protection function to work 3 seconds later and the power supply will be shut off.

原因: パワーアンプのDC出力が異常。

補足: 異常時の電圧の状態を、5Vを255とした値で表示します。

異常状態のままパワーオンすると、3秒後にプロテクションがかかり、電源が切れます。

When there is a history of protection
function due to excessive heat sink
temperature
放熱器の異常温度によるプロテク
ション履歴がある場合 \

Version (1 alphabet)
バージョン(英1文字)

TMPx PRT:000 A

A/D conversion value of voltage
電圧のA/D変換値

Cause: The temperature of the heat sink is excessive.

Supplementary information: The abnormal voltage is displayed in based on 5V as 255.

Turning on the power without correcting the abnormality will cause the protection function to work 1 second later and the power supply will be shut off.

原因: 放熱器の温度が異常。

補足: 異常時の電圧の状態を、5Vを255とした値で表示します。

異常状態のままパワーオンすると、1秒後にプロテクションがかかり、電源が切れます。

* Additional causes of protection can be due to loose connections, associated components, Microprocessor, etc.

* For the protection voltage value, refer to DIAG menu No.12 described later.

※ 前記の異常原因の他に、コネクタのはずれやMicro-processor周辺などに原因があります。

※ プロテクションの電圧値に関しては、後述のダイアグメニューNo.12を参照してください。

● History of protection function

When the protection function has worked, its history is stored in memory with a backup. Even if no abnormality is noted while servicing the unit, an abnormality which has occurred previously can be defined as long as the backup data has been stored.

The history of the protection function is cleared when DIAG is cancelled by selecting PRESET RESERVED (Memory initialized) of DIAG menu No. 11 or when the backup data is erased.

● プロテクションの履歴

プロテクションが働いた場合、履歴をバックアップして記憶しています。サービスのときに異常が認められなくても、バックアップが残っていれば、お客様のところで起きた異常を区別できます。

プロテクションの履歴は、ダイアグメニューNo.11で PRESET RESERVED (メモリーの初期化) を選んでダイアグを解除した場合や、バックアップが消えたときにはクリアされます。

● Display during menu operation

During the DIAG mode, the monitor screen shows the wall paper and the function at work among following functions as a short message.

- Input selection, multi channel input
- Muting
- Speaker relay A/B
- Master volume

The FL display of the main unit shows the function at work. The displayed contents are described in the later section on detailed functions.

● メニュー動作中の表示

ダイアグ中、モニター画面には壁紙表示と以下の動作中の機能がショートメッセージとして表示されます。

- インプット切替、マルチチャンネルインプット
- ミューティング
- スピーカーリレーA/B
- マスターボリューム

本機のFLディスプレイには動作中の機能が表示されます。機能動作中の表示内容については、後述の機能詳細で記述します。

● Operation procedure of DIAG menu and SUB-MENU

There are 27 MENU items, each of which has some SUB-MENU items.

DIAG menu selection

Select the menu using PROGRAM knob.

● ダイアグメニューとサブメニューの操作

ダイアグにはNo.1~27のメニューがあり、そのそれぞれにサブメニューがあります。

ダイアグメニューの選択

PROGRAMツマミで選択します。

SUB-MENU selection

Select the sub-menu using ▷ (Forward) and ◁ (Reverse) keys of PRESET/TUNING.

サブメニューの選択

PRESET/TUNING ▷ (順送り), ◁ (逆送り) キーで選択します。

SUB-MENU selection
サブメニューの選択

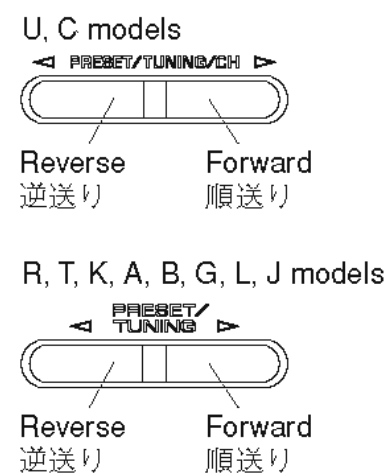

DIAG menu selection
ダイアグメニューの選択

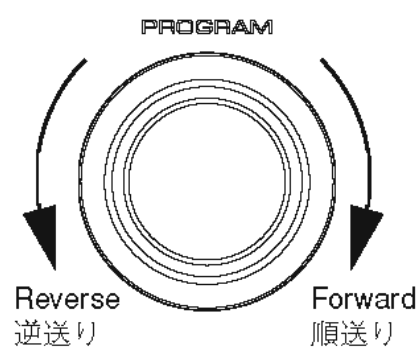

● Functions in DIAG mode

In addition to the DIAG menu items, functions as listed below are available.

- Input selection, Multi channel input
 - Center/Rear/Rear center/Sub-woofer level adjustment
 - Muting
 - Speaker relay A/B
 - Power on/off
 - Master volume
- * Functions related to the tuner and the set menu are not available.
- * It is possible to confirm Menu No.14 IF STATUS while keeping the signal process (operation status) of each DIAG menu by using the "AUDIO SELECT" key of the main unit.

● Initial settings used to start DIAG

The following initial settings are used when starting DIAG. When DIAG is canceled, these settings are restored to those before starting DIAG.

- Master volume: -20dB
- Input: DVD (MULTI CHANNEL INPUT OFF)
- Effect level: 0dB
- Audio mute: OFF
- Speaker relay A/B: ON
- Speaker setting: LARGE / BASS OUT = BOTH
- DIAG menu: DA60Y-YSS930 (1. MARGIN)

● ダイアグ中の機能

ダイアグメニューの他に、以下の機能が動作します。

- インプット切り換え、マルチチャンネルインプット
- センター、リア、リアセンター、サブウーファーレベル調整
- ミューティング
- スピーカーリレーA/B
- パワーオン/オフ
- マスターボリューム

※ チューナー関連、セットメニュー関連は機能しません。

※ 本機の“AUDIO SELECT”キーにより、各ダイアグメニューの信号処理(動作状態)を維持したままダイアグメニューNo.14 IF STATUSの確認ができます。

● ダイアグ開始時の初期設定

ダイアグ開始時に以下のような設定になります。ダイアグ解除時にはダイアグ開始前の状態に戻ります。

- マスターボリューム: -20dB
- インプット: DVD (マルチチャンネルINPUT オフ)
- エフェクトレベル: 0dB
- オーディオミュート: オフ
- スピーカーリレーA/B: オン
- スピーカー設定: LARGE / BASS OUT=BOTH
- ダイアグメニュー: DA60Y-YSS930 (1. MARGIN)

RX-V1600/DSP-AX1600

● Details of DIAG menu

With full-bit output specified in some modes, it is possible to execute 0dBFS output without head margin in each channel.

1. DA60Y-YSS930

This function is for YSS930 only. Main DSP of YSS930 is selected for FRONT output.

Using the sub-menu, it is possible to select 0dB output level or full-bit output.

MARGIN

- The signal is output including the head margin.

● ダイアグメニュー詳細

一部のモードでフルビット指定することで、各チャンネルのヘッドマージンを廃して0dBFS出力することが可能です。

1. DA60Y-YSS930

YSS930のみの動作です。FRONT出力にはYSS930のMain DSPが選択されます。

サブメニューにより、出力レベル0dB、フルビット出力が選択可能です。

MARGIN

- ヘッドマージンを含んで出力されます。

1. DA60Y-YSS930
MARGIN

INPUT: DVD ANALOG

SPEAKER OUT: 1kHz, SUBWOOFER OUTPUT: 50Hz

Input level	Volume	SPEAKER OUT					SUBWOOFER OUTPUT
		FRONT	CENTER	SURROUND	SURROUND BACK	PRESENCE	
Both ch, -20 dBm	+6.5 dB	+18.5 dBm	+12.5 dBm	+12.5 dBm	+12.5 dBm	-∞	-6.0 dBm

FULL BIT

- The signal is output in digital full bit without including the head margin.
- The SWFR signal is output but not in digital full bit.

FULL BIT

- ヘッドマージンを含まず、デジタルフルビットで出力されます。
- SWFRは出力されますが、デジタルフルビットではありません。

1. DA60Y-YSS930
FULL BIT

INPUT: DVD ANALOG

SPEAKER OUT: 1kHz, SUBWOOFER OUTPUT: 50Hz

Input level	Volume	SPEAKER OUT					SUBWOOFER OUTPUT
		FRONT	CENTER	SURROUND	SURROUND BACK	PRESENCE	
Both ch, -20 dBm	+6.5 dB	+18.5 dBm	+12.5 dBm	+12.5 dBm	+12.5 dBm	-∞	-6.0 dBm

DA60Y-YSS930
(ANALOG)

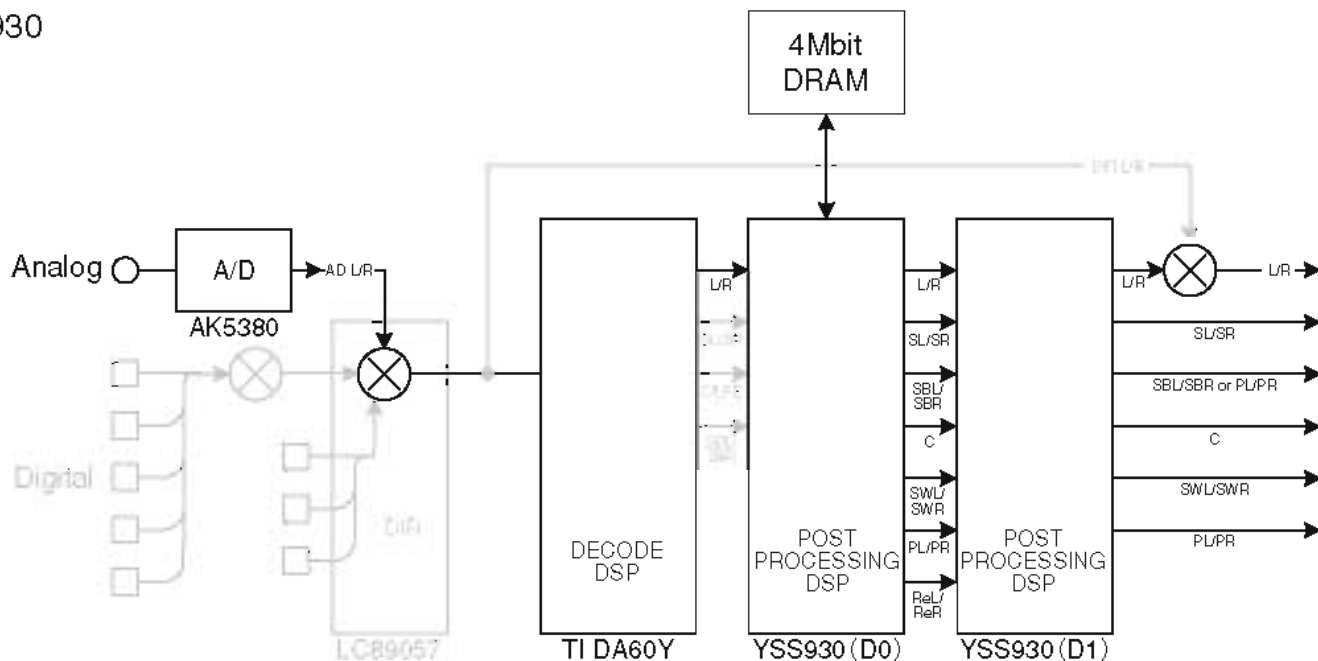

(Shaded items not used in this example)

2. BYPASS

2. BYPASS

ANALOG BYPASS

ANALOG BYPASS

2. BYPASS
ANALOG BYPASS

INPUT: DVD ANALOG
SPEAKER OUT: 1kHz, SUBWOOFER OUTPUT: 50Hz

Input level	Volume	SPEAKER OUT					SUBWOOFER OUTPUT
		FRONT	CENTER	SURROUND	SURROUND BACK	PRESENCE	
Both ch, -20 dBm	+6.5 dB	+18.5 dBm	-∞	-∞	-∞	-∞	-∞

DSP BYPASS

DSP BYPASS

2. BYPASS
DSP BYPASS

INPUT: DVD ANALOG
SPEAKER OUT: 1kHz, SUBWOOFER OUTPUT: 50Hz

Input level	Volume	SPEAKER OUT					SUBWOOFER OUTPUT
		FRONT	CENTER	SURROUND	SURROUND BACK	PRESENCE	
Both ch, -20 dBm	+6.5 dB	+18.5 dBm	-∞	-∞	-∞	-∞	-∞

ANALOG BYPASS, DSP BYPASS
(ANALOG)

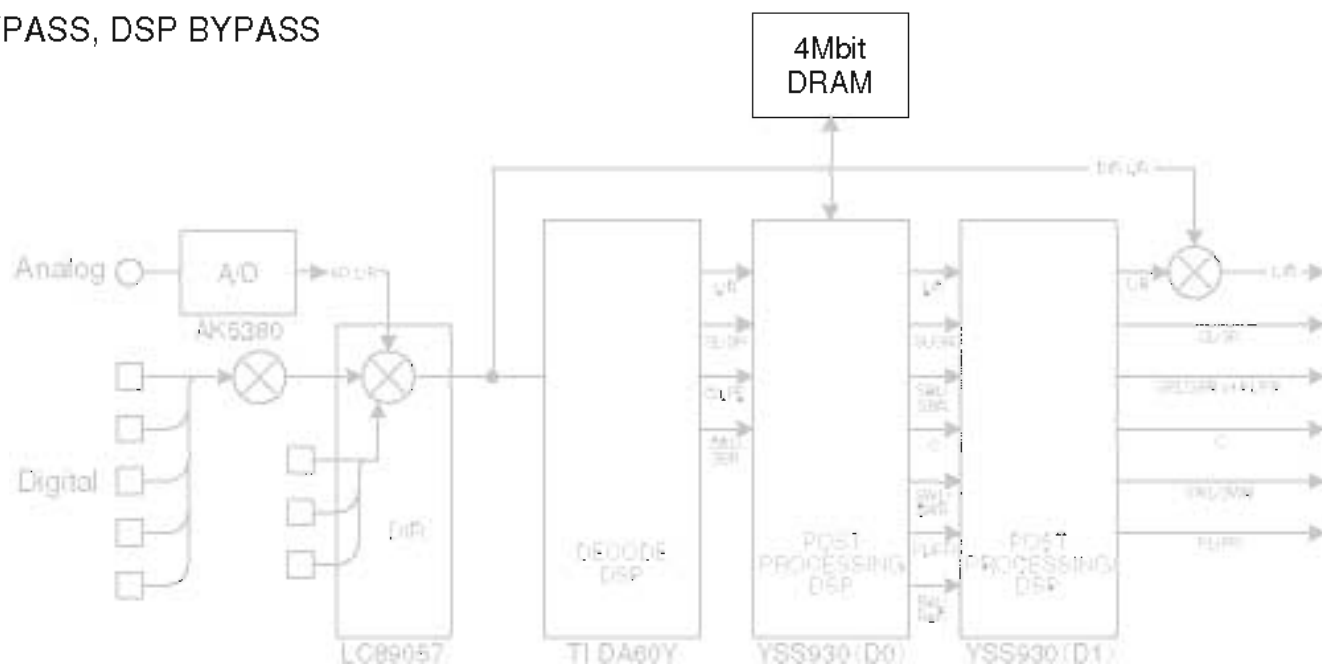

(Shaded items not used in this example)

DSP BYPASS
(DIGITAL)

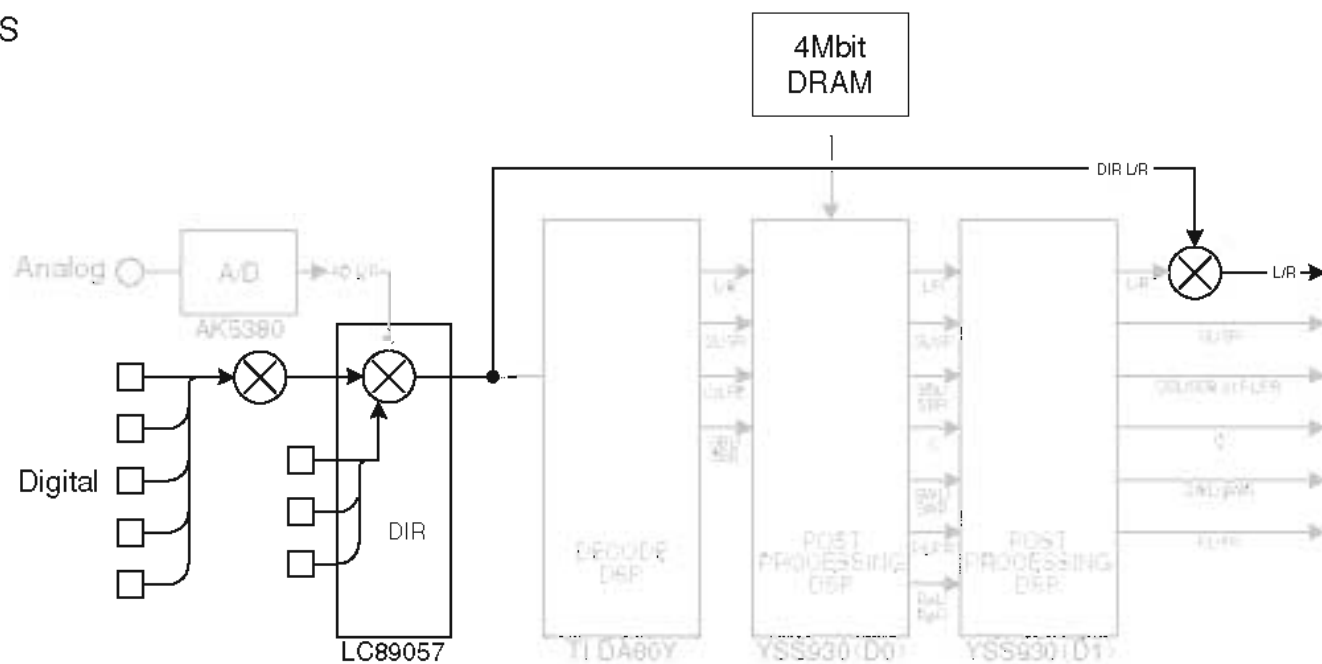

(Shaded items not used in this example)

RX-V1600/DSP-AX1600

3. RAM THROUGH

Using the sub-menu, it is possible to select the full-bit output at 0dB output level.

MARGIN

3. RAM THROUGH
MARGIN

INPUT: DVD ANALOG
SPEAKER OUT: 1kHz, SUBWOOFER OUTPUT: 50Hz

Input level	Volume	SPEAKER OUT					SUBWOOFER OUTPUT
		FRONT	CENTER	SURROUND	SURROUND BACK	PRESENCE	
Each ch, -20 dBm	+6.5 dB	+18.5 dBm	+12.5 dBm	+12.5 dBm	+12.5 dBm	-∞	-6.0 dBm

FULL BIT

- MAIN -9dB

3. RAM THROUGH
FULL BIT

INPUT: DVD ANALOG
SPEAKER OUT: 1kHz, SUBWOOFER OUTPUT: 50Hz

Input level	Volume	SPEAKER OUT					SUBWOOFER OUTPUT
		FRONT	CENTER	SURROUND	SURROUND BACK	PRESENCE	
Both ch, -20 dBm	+6.5 dB	+18.5 dBm	+12.5 dBm	+12.5 dBm	+12.5 dBm	-∞	-6.0 dBm

**RAM THROUGH
(ANALOG)**

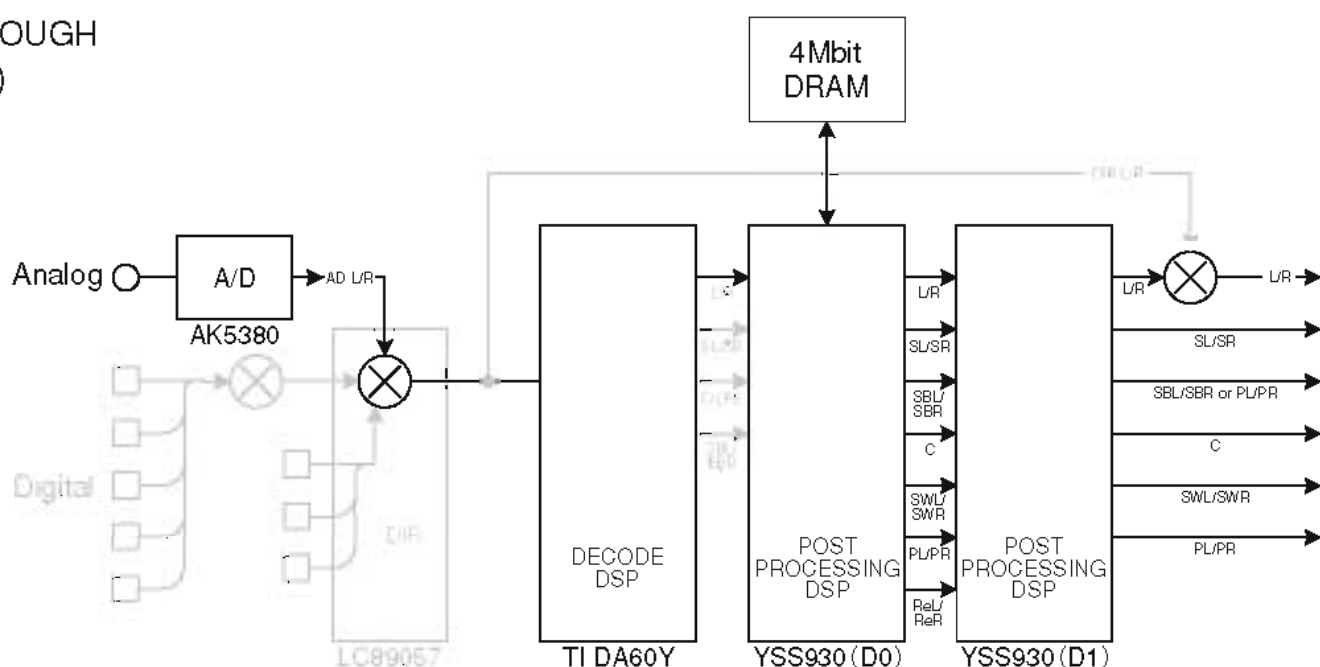

(Shaded items not used in this example)

4. HDMI AUDIO

The signals input to HDMI IN1 and IN2 are selected by the sub-menu and output.

4. HDMI AUDIO

HDMI IN1、IN2に入力された信号をサブメニューで選択し、出力します。

SPDIF

Only SPDIF is output.

SPDIF

SPDIFのみを出力します。



Multi

Only Multi (DVD-AUDIO) is output.

Multi

Multi(DVD-AUDIO)のみを出力します。



DSD

Not applied to this model.

DSD

このモデルには適用されません。



DSD Direct

Not applied to this model.

DSD Direct

このモデルには適用されません。



5. SPEAKERS SET

The input signal is automatically identified in the order of dts→DOLBY DIGITAL→AAC→PCM→Analog. There are 11 sub-menu items as follows. The signals output from the DSP block are the same as sub-menu MARGIN of DIAG menu No.1 DA60Y-YSS930.

5. SPEAKERS SET

入力は、dts→DOLBY DIGITAL→AAC→PCM→アナログの優先順で自動判別されます。サブメニューは以下の11つあります。DSP部からは、No.1 DA60Y-YSS930のMARGINと同様の信号が出力されます。

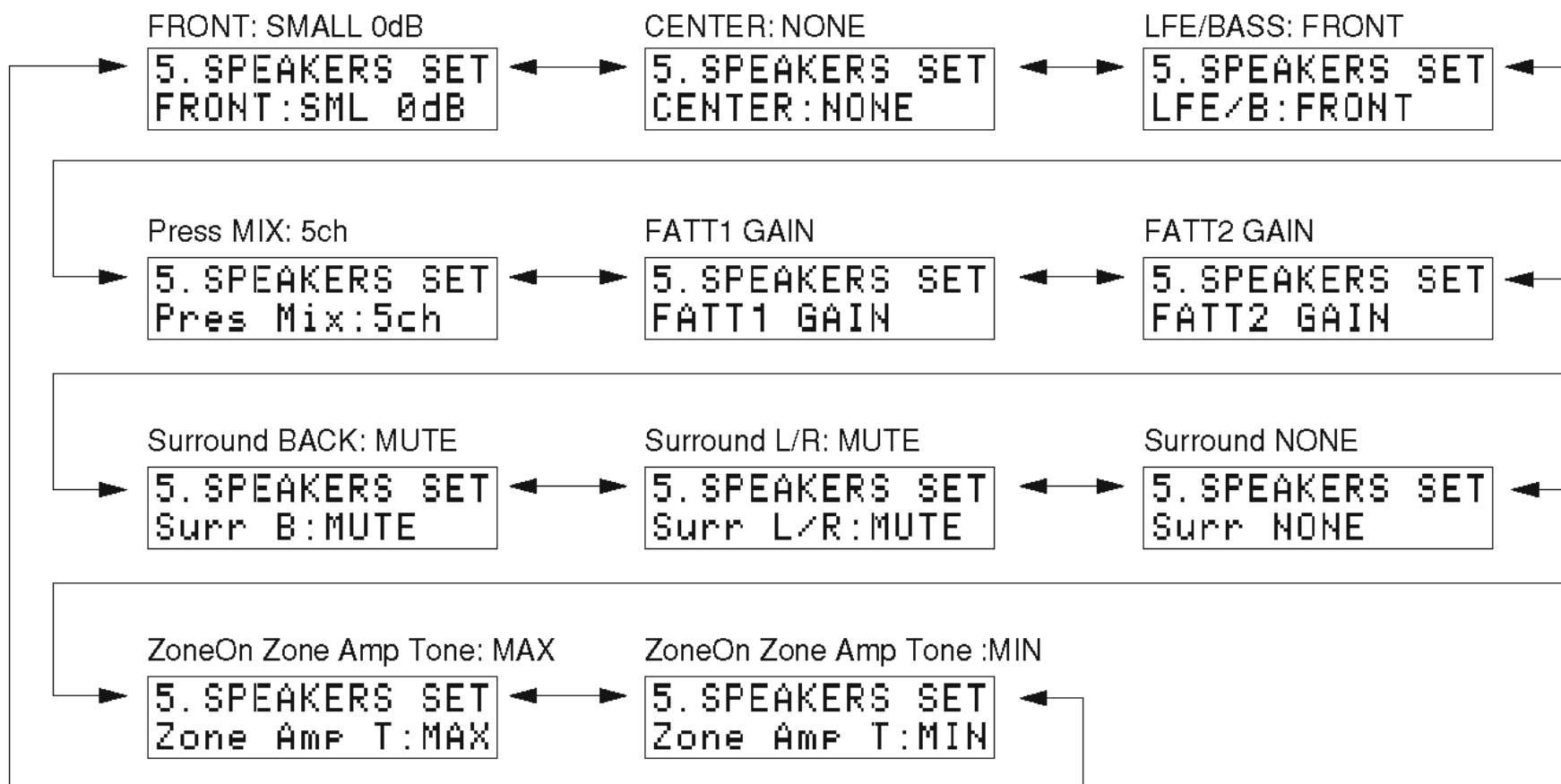

RX-V1600/DSP-AX1600

The analog switch settings for each sub-menu are as shown in the table below.

各サブメニューにおけるアナログスイッチの設定は以下の通りです。

SUB MENU	FRONT L/R	CENTER	SURROUND L/R	SURROUND BACK L/R	LFE/BASS
1. FRONT: SMALL 0dB	SMALL	LARGE	LARGE	LARGE	SWFR
2. CENTER: NONE	LARGE	NONE	LARGE	LARGE	SWFR
3. LFE/B: FRNT	LARGE	SMALL	SMALL	SMALL	FRONT
4. Pres Mix: 5ch	LARGE	LARGE	LARGE	LARGE	SWFR
5. FATT1 GAIN	LARGE	LARGE	LARGE	LARGE	SWFR
6. FATT2 GAIN	LARGE	LARGE	LARGE	LARGE	SWFR
7. Surr B: MUTE	LARGE	LARGE	LARGE	NONE	SWFR
8. Surr L/R: MUTE	LARGE	LARGE	NONE	LARGE	SWFR
9. Surr NONE	LARGE	LARGE	NONE	NONE	SWFR
10. ZoneOn Zone Amp Tone: MAX	LARGE	LARGE	NONE	NONE	SWFR
11. ZoneOn Zone Amp Tone: MIN	LARGE	LARGE	NONE	NONE	SWFR

- LARGE: This mode is used with a speaker with high bass reproduction performance (a large unit). Full bandwidth signals are output.
- SMALL: This mode is used with a speaker with low bass reproduction performance (a small unit). The signals of 90Hz or less are mixed into the channel specified by LFE/BASS.
- NONE: This mode is used with no center speaker. The center content is reduced by 3dB and distributed to FRONT L/R.
- SWFR: LFE of 5.1ch signal or LFE/BASS lower than 90Hz is output through SUBWOOFER OUT.
- FRONT: LFE of 5.1ch signal or LFE/BASS lower than 90Hz is distributed to FRONT L/R.

- LARGE: 低音再生能力の高い(ユニットの大きい)スピーカーを使用するモードです。全帯域が出力されます。
- SMALL: 低音再生能力の低い(ユニットの小さい)スピーカーを使用するモードです。90Hz以下がLFE/BASSで指定したチャンネルにミックスされます。
- NONE: スピーカーを使用しないモードです。センター成分は-3dBされて、FRONT L/Rに振り分けられます。
- SWFR: 5.1ch信号のLFEまたは90Hz以下のLFE/BASSがSUBWOOFER OUTに出力されます。
- FRONT: 5.1ch信号のLFEまたは90Hz以下のLFE/BASSをFRONT L/Rに振り分けます。

INPUT: DVD ANALOG
 SPEAKER OUT: 1kHz, SUBWOOFER OUTPUT: 50Hz
 Input level: Both ch, -20 dBm
 Volume: +6.5 dB

SUB MENU	SPEAKER OUT					SUBWOOFER OUTPUT
	FRONT	CENTER	SURROUND	SURROUND BACK	PRESENCE	
1. FRONT: SMALL 0dB	+18.5 dBm	+12.5 dBm	+12.5 dBm	+12.5 dBm	-∞	-2.5 dBm
2. CENTER: NONE	+6.5 dBm	-∞	+12.5 dBm	+12.5 dBm	-∞	-6.0 dBm
3. LFE/B: FRNT	+25.0 dBm	+5.0 dBm	+3.5 dBm	+3.5 dBm	-∞	-∞
4. Pres Mix: 5ch	+13.5 dBm	+12.5 dBm	+12.5 dBm	+12.5 dBm	-∞	-6.0 dBm
5. FATT1 GAIN	+19.0 dBm	+12.5 dBm	+12.5 dBm	+12.5 dBm	-∞	-6.0 dBm
6. FATT2 GAIN	+18.5 dBm	+12.5 dBm	-∞	+12.5 dBm	-∞	-6.0 dBm
7. Surr B: MUTE	+18.5 dBm	+12.5 dBm	-∞	-∞	+12.5 dBm	-6.0 dBm
8. Surr L/R: MUTE	+18.5 dBm	+12.5 dBm	-∞	+12.5 dBm	-∞	-6.0 dBm
9. Surr NONE	+13.0 dBm	+12.5 dBm	-∞	-∞	+12.5 dBm	-6.0 dBm
10. ZoneOn Zone Amp Tone: MAX	+18.5 dBm	+12.5 dBm	-∞	-∞	-∞	-6.0 dBm
11. ZoneOn Zone Amp Tone: MIN	+18.5 dBm	+12.5 dBm	-∞	-∞	-∞	-6.0 dBm

6. Multi INPUT

It is possible to select the 6ch/8ch input and 6 ohms/8 ohms by using the SUB menu.

6CH INPUT_6 ohms

```
6.Multi INPUT
6ch INPUT_6Ω
```

INPUT: MULTI CH INPUT

SPEAKER OUT: 1kHz, SUBWOOFER OUTPUT: 50Hz

Input level	Volume	SPEAKER OUT					SUBWOOFER OUTPUT
		FRONT	CENTER	SURROUND	SURROUND BACK	PRESENCE	
Both ch, -20 dBm	+6.5 dB	+19.0 dBm	+13.0 dBm	+13.0 dBm	-∞	-∞	-6.5 dBm

6. Multi INPUT

サブメニューにより、6ch/8ch入力および6オーム/8オームが選択可能です。

6CH INPUT_6オーム**8CH INPUT_6 ohms**

```
6.Multi INPUT
8ch INPUT_6Ω
```

INPUT: MULTI CH INPUT

SPEAKER OUT: 1kHz, SUBWOOFER OUTPUT: 50Hz

Input level	Volume	SPEAKER OUT					SUBWOOFER OUTPUT
		FRONT	CENTER	SURROUND	SURROUND BACK	PRESENCE	
Both ch, -20 dBm	+6.5 dB	+19.0 dBm	+13.0 dBm	+13.0 dBm	+12.5 dBm	-∞	-6.5 dBm

8CH INPUT_6オーム**6CH INPUT_8 ohms**

```
6.Multi INPUT
6ch INPUT_8Ω
```

INPUT: MULTI CH INPUT

SPEAKER OUT: 1kHz, SUBWOOFER OUTPUT: 50Hz

Input level	Volume	SPEAKER OUT					SUBWOOFER OUTPUT
		FRONT	CENTER	SURROUND	SURROUND BACK	PRESENCE	
Both ch, -20 dBm	+6.5 dB	+19.0 dBm	+13.0 dBm	+13.0 dBm	-∞	-∞	-6.5 dBm

6CH INPUT_8オーム**8CH INPUT_8 ohms**

```
6.Multi INPUT
8ch INPUT_8Ω
```

INPUT: MULTI CH INPUT

SPEAKER OUT: 1kHz, SUBWOOFER OUTPUT: 50Hz

Input level	Volume	SPEAKER OUT					SUBWOOFER OUTPUT
		FRONT	CENTER	SURROUND	SURROUND BACK	PRESENCE	
Both ch, -20 dBm	+6.5 dB	+19.0 dBm	+13.0 dBm	+13.0 dBm	+12.5 dBm	-∞	-6.5 dBm

8CH INPUT_8オーム

RX-V1600/DSP-AX1600

TMP TEST

Perform the fan drive test.
Operation is changed using the "STRAIGHT" key.

TMP TEST (温度試験モード)

ファンの駆動テストを行います。
操作は"STRAIGHT"キーで切り替えます。

```
6. Multi INPUT
255000058059 _
```

_: OFF
L: LOW / 弱
M: MID / 中
H: HIGH / 強

7. MIC CHECK

The signals inputted through the microphone are output
via A/D - D/A.

7. MIC CHECK

マイク入力された信号をA/D-D/A経由で出力します。

```
7. MIC CHECK
--- db
```

8. STRAIGHT / DISPLAY CHECK

Use this program to check the FL display section and image control section. When checking the image control section, prepare a monitor, component video cable, S video cable and video pin cable and connect them. Using the sub-menu operation, the display status of the FL display section and image control section varies as shown below.
For audio signal processing, use EFFECT OFF (L/R output by using ANALOG MAIN BYPASS).

8. STRAIGHT / DISPLAY CHECK

FL表示部と映像制御部のチェックプログラムです。映像制御部をチェックする場合には、モニター、D端子ケーブル、コンポーネントビデオケーブル、Sビデオケーブル、ビデオ用ピンケーブルを準備し接続します。サブメニュー操作により、FL表示部と映像制御部の表示状態が以下のように連動して変わります。オーディオ信号処理はEFFECT OFF (ANALOG MAIN BYPASSでL/Rを出力)です。

Checking FL display section

FL表示部のチェック

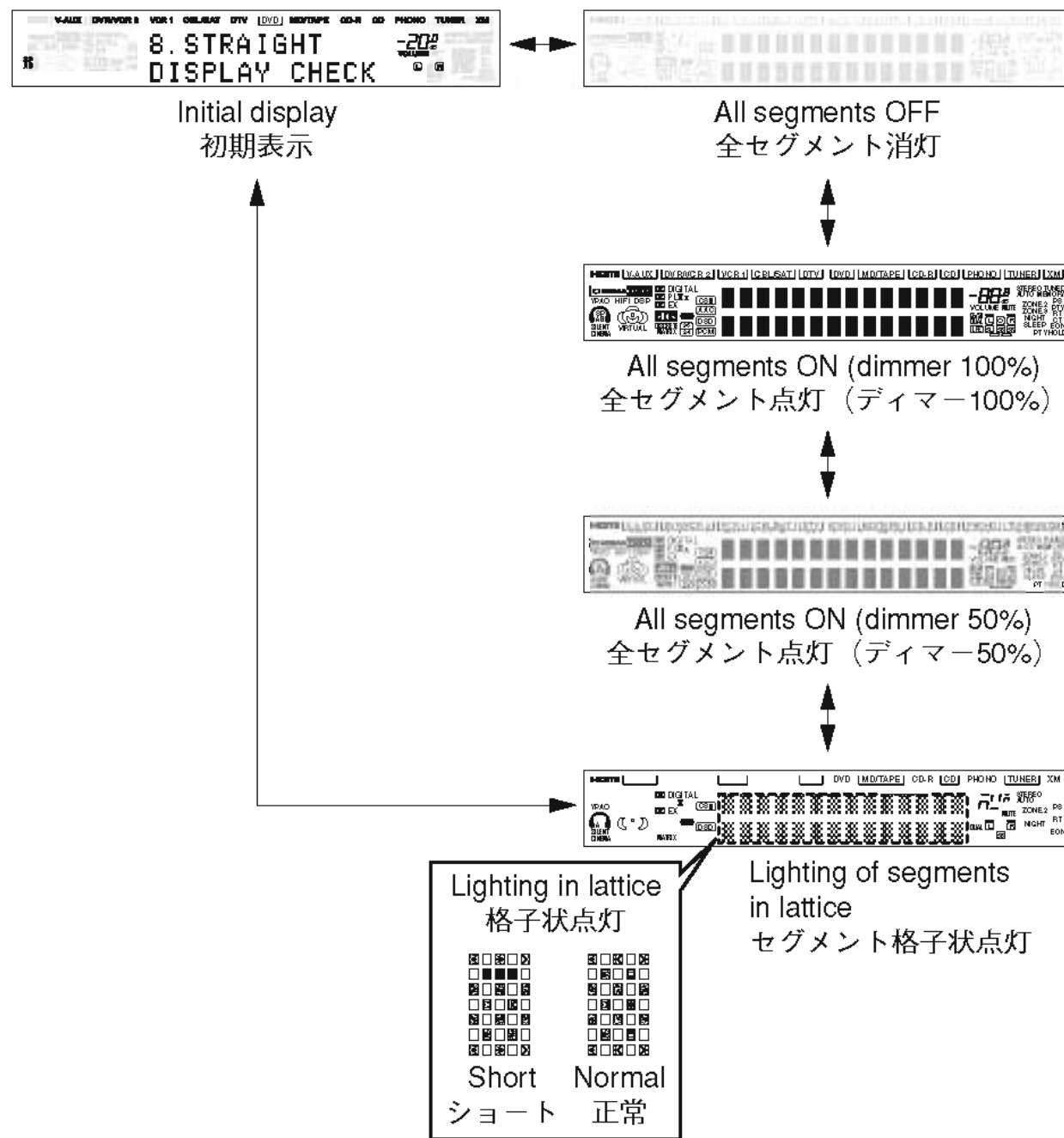

Segment conditions of the FL driver and the FL tube are checked by turning ON and OFF all segments. Next, the operation of the FL driver is checked by using the dimmer control. Then a short between segments next to each other is checked by turning ON and OFF all segments alternately (in lattice). (In the above example, the segments in the second row from the top are shorted.)

全セグメント消灯・全セグメント点灯によりFLドライバー、FL管のセグメントの不良を確認します。次に、ディマーコントロールによってFLドライバーの動作チェックを行います。さらに全セグメントを交互(格子状)に点灯/消灯することで、隣り合うセグメントのショートをチェックします。

RX-V1600/DSP-AX1600

Check of the Video control circuit. (Monitor out) / 映像表示部のチェック (モニター出力)

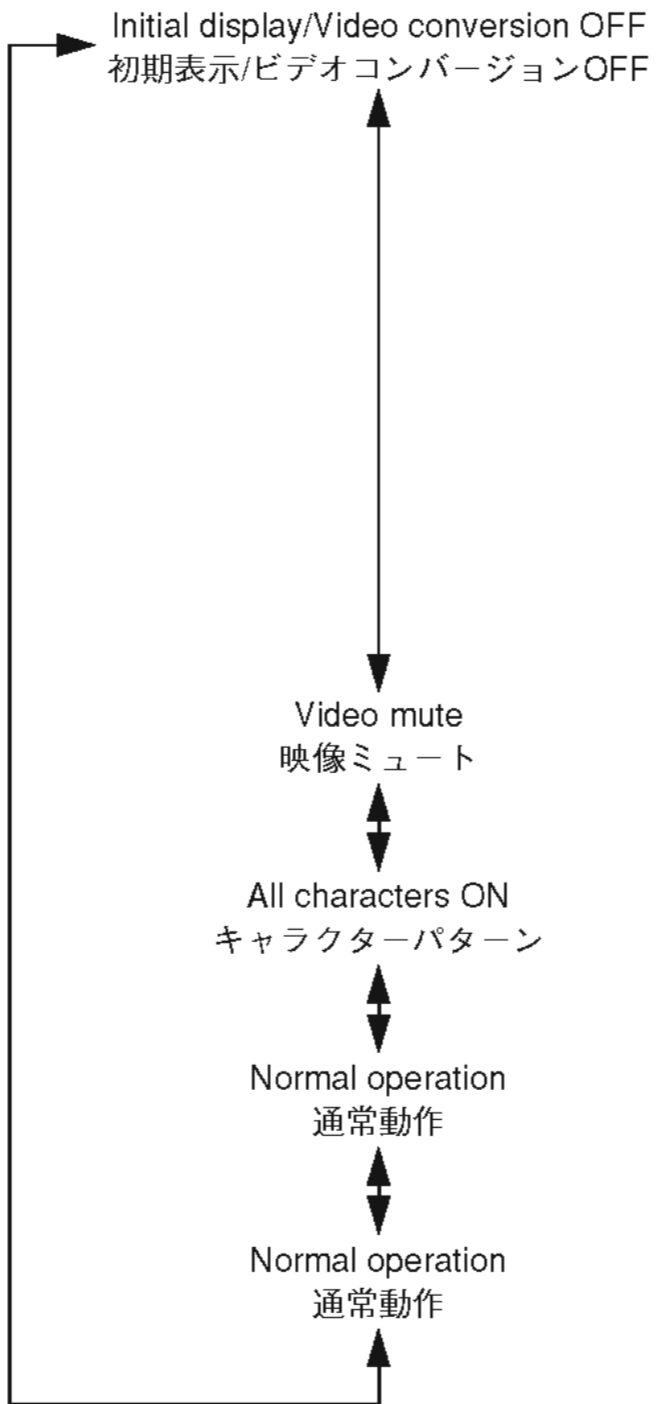

The image signal is output as follows.
映像信号は以下のように出力されます。

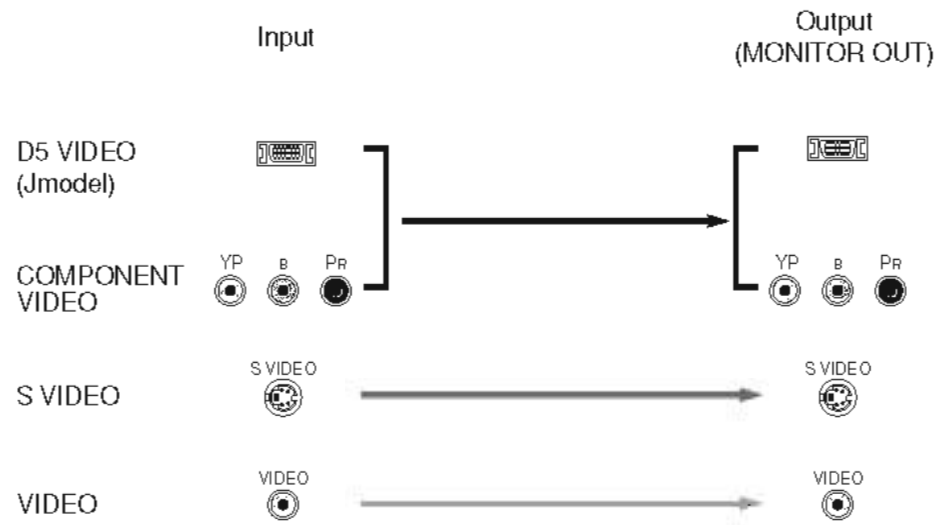

The image signal is not output.
映像信号は出力されません。

The 128 pictographs for checking the OSD driver are used for the ZONE2 Video output.
ZONE2 VIDEO OUT (ZONE2)にOSDドライバー確認用128絵文字が出力されます。

9. MANUAL TEST

The noise generator with a built-in DSP outputs the test noise through the channels specified by the sub-menu. The noise frequency for LFE is 35 to 250 Hz. Other than that, the center frequency is 800Hz.

9. MANUAL TEST

DSP内蔵のノイズ発生回路によって、サブメニューで指定したチャンネルへテストノイズを出力します。LFE用のノイズ周波数は35~250Hz、それ以外は中心周波数800Hzとなります。

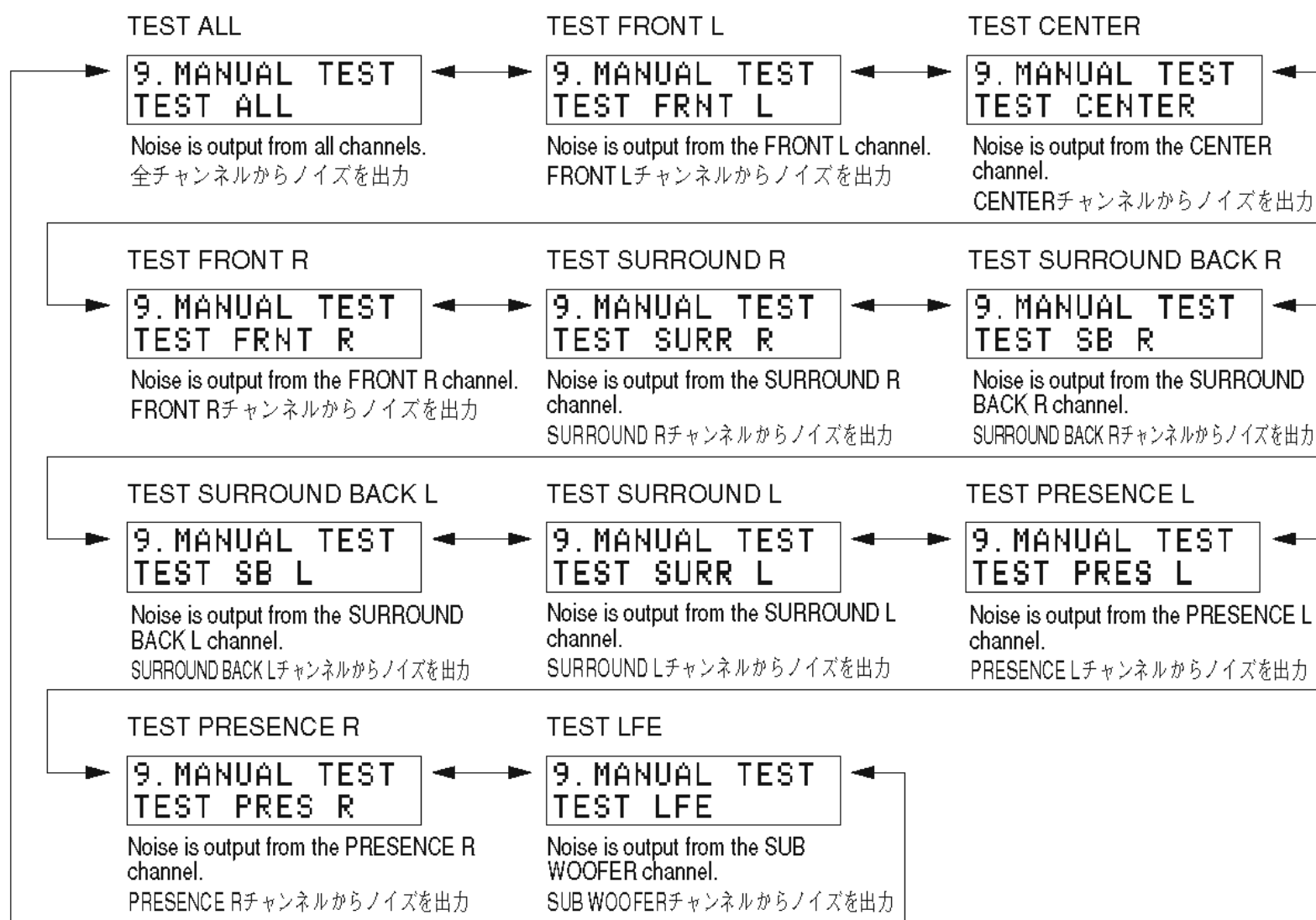

10. RS-232C

This menu is used to check transmission of the data and the flow port of the hardware. With the power turned off, short between pins No.2 (RxD) and No.3 (TxD), and between pins No.7 (RTS) and No.8 (CTS) of the RS-232C terminal. (Be sure to turn off the power when shorting the pins.) Start DIAG and select the menu. There are two sub-menu items.

10. RS-232C

データ送受信チェック、ハードウェアフローポートチェックを行うメニューです。パワーオフ状態にしてから、RS-232C端子の2ピン(RxD)と3ピン(TxD)、7ピン(RTS)と8ピン(CTS)をショートさせます。(ショートさせるときは必ず電源を切ってください。)ダイアグを起動してメニューを選択します。サブメニューは2つあります。

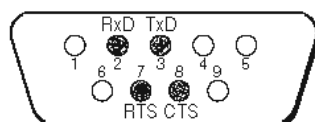

TX DATA

The sub-menu is used to check transmission of the test data. "OK" appears when the data is transmitted properly and "NG" when it is not. In this mode, NULL command transmission is continued after the test command is transmitted.

TX DATA

テストの送受信チェックを行います。正常に送受信完了した場合、「OK」と表示します。正常に送受信しなかった場合は「NG」と表示します。このモードでは、テストコマンド送信後、200msごとにNULLコマンド(無効なコマンド)を送信し続けます。

10. RS-232C
TX DATA: NG

RX-V1600/DSP-AX1600

HARD FLOW

This sub-menu is used to check operation of the flow port of the hardware. "OK" appears when the check result is satisfactory and "NG" when it is not.

HARD FLOW

ハードウェアフローポートの動作チェックを行います。正常にチェック完了した場合、“OK”と表示します。正常にチェック完了しなかった場合は“NG”と表示します。

10. RS-232C
HARD FLOW: NG

11. FACTORY PRESET

This menu is used to reserve and inhibit initialization of the back-up RAM. The signals are processed using EFFECT OFF. (The L/R signal is output using ANALOG MAIN BYPASS.)

11. FACTORY PRESET

バックアップ用RAM (音場プログラムのパラメーターやセットメニュー内容等)の初期化を予約/禁止します。信号処理はEFFECT OFFと同じです。(ANALOG MAIN BYPASSでL/Rを出力)

11. FAC PRESET
PRESET INH



11. FAC PRESET
PRESET RSRV

PRESET INHIBIT (Initialization inhibited) / PRESET INHIBIT (初期化禁止)

RAM initialization is not executed. Select this sub-menu to protect the values set by the user.

RAMの初期化は行われません。ユーザーの設定値を保護するときは、こちらを選択してください。

PRESET RESERVED (Initialization reserved) / PRESET RESERVED (初期化予約)

Initialization of the back-up RAM is reserved. (Actually, initialization is executed the next time that the power is turned on.) Select this sub-menu to reset to the original factory settings or to reset the RAM. Any protection history will be cleared.

バックアップRAMの初期化が予約されます。(実際に初期化されるのは、次回の電源投入時です。)工場出荷時やRAMをリセットしたいときは、こちらを選択してください。

CAUTION: Before setting to the PRESET RESERVED, write down the existing preset memory content of the Tuner in a table as shown below. (This is because setting to the PRESET RESERVED will cause the user memory content to be erased.)

注意： PRESET RESERVEDを選んで初期化をする前に、チューナーのユーザーメモリー内容を下表に書き写してください。(初期化をすると、ユーザーメモリーの内容は消えてしまいます。)

Preset group	P1	P2	P3	P4	P5	P6	P7	P8
A								
B								
C								
D								
E								

• PRESET STATIONS / プリセット局

STATION		FM FACTORY PRESET DATA (MHz)		
PAGE	NO.	U, C	R, T, K, A, B, G, L	J
A/C/E	1	87.5	87.50	76.0
	2	90.1	90.10	83.0
	3	95.1	95.10	84.0
	4	98.1	98.10	86.0
	5	107.9	108.00	90.0
	6	88.1	88.10	78.0
	7	106.1	106.10	88.0
	8	107.9	108.00	82.1

STATION		AM FACTORY PRESET DATA (kHz)		
PAGE	NO.	U, C, R, T, K	A, B, G, L	J
B/D	1	630	630	630
	2	1080	1080	1080
	3	1440	1440	1440
	4	530	531	531
	5	1710	1611	1611
	6	900	900	900
	7	1350	1350	1350
	8	1400	1404	1404

12. AD DATA CHECK

This menu is used to display the A/D conversion value of the main Microprocessor which detects panel keys of the main unit and protection functions in using the sub-menu. During signal processing, the condition before execution is maintained.

When K0/K1 menu is selected, keys become non-operable due to detection of the values of all keys. However, it is possible to advance to the next sub-menu by turning the VOLUME of the main unit. When using this function, note that turning the VOLUME more than 1 click would cause the volume value to change.

* The figures in the diagram are given as reference only.

DC (protection detection)

DC: DC detect protection value (Normal value: 3 to 33)

* If DC is out of the normal value range, the protection function works to turn off the power.

(Reference voltage: 5V=255)

```
12. AD CHECK
DC: 021
```

PS1/PS2 (Power supply voltage protection detection)

Power supply voltage protection value (Normal value: PS1: 76 to 106, PS2: 62 to 97)

PS1: Detects $\pm B1$, $\pm B2$, $\pm B4$, $\pm B5$, $\pm 12V$, $+5D1$, $+5D2$, $+5V2$, $+5V3$, $+5VBUS$ (U, C models) and $+2.5D$.

PS2: Detects $+9V$, $\pm 5V$ and $+7V$.

* If PS is out of the normal value range, the protection function works to turn off the power.

(Reference voltage: 5V=255)

```
12. AD CHECK
PS1: 091 PS2: 079
```

TM1/TM2 (temperature detection)

Temperature detected value

(Normal value: 20 to 182) U, C, T, K, A, B, G models

(Normal value: 20 to 176) R, L, J models

TM1: Detects the temperatur of the front heat sink.

TM2: Detects the temperatur of the rear heat sink.

(Reference voltage: 5V=255)

```
12. AD CHECK
TM1: 059 TM2: 060
```

12. AD DATA CHECK

本機パネルキー、プロテクションなどを検出しているメインMicroprocessorのA/D変換の値を、サブメニューで表示します。信号処理は実行前の状態を維持します。K0/K1のメニューにすると、全キーの値を検出するためキー操作はできなくなりますが、本機のVOLUMEを回すことにより、次のサブメニューに進めることができます。このとき1クリック以上回すと、ボリューム値が変化するので注意してください。

※図中の数値は参考例です。

DC (プロテクションの検出)

DC: DC検出プロテクションの値(正常値3~33)

※ DCは正常値を外れるとプロテクションが働き、電源オフされます。

(基準電圧: 5V=255)

PS1/PS2 (電源電圧プロテクションの検出)

プロテクションの値(正常値 PS1: 76~106、PS2: 62~97)

PS1: $\pm B1$ 、 $\pm B2$ 、 $\pm B4$ 、 $\pm B5$ 、 $\pm 12V$ 、 $+5D1$ 、 $+5D2$ 、 $+5V2$ 、 $+5V3$ 、 $+2.5D$ を検出しています。

PS2: $+9V$ 、 $\pm 5V$ 、 $+7V$ を検出しています。

※ PSは正常値を外れるとプロテクションが働き、電源オフされます。

(基準電圧: 5V=255)

TM1/TM2 (温度検出)

温度検出値(正常値: 20~176)

TM1: フロントヒートシンクの温度を検出しています。

TM2: リアヒートシンクの温度を検出しています。

(基準電圧: 5V=255)

RX-V1600/DSP-AX1600

RECOUT SEL (Select position)
Not applied to this model.

RECOUT SEL (選択位置表示)
このモデルには適用されません。

12. AD CHECK
RECOUT: 244

POWER LIMITER (Power limiter detection)
Power limiter detection value
The voltage value of pin No. 141 of IC301 is displayed, using 5V/255 as standard.
Based on the input voltage value of pin No. 141 of IC301, the output of pins No. 3 of IC301 is controlled.

POWER LIMITER (パワーリミッターの検出)
パワーリミッター検出の値
IC301の141ピンの電圧値を5V/255を基準にして表示します。
IC301の141ピンの入力電圧値により、IC301の3ピンの出力を制御します。

12. AD CHECK
PLIMIT: 000

LIMIT
Limiter control value
The voltage at 3 pin of IC301 is displayed with 5V/255 as a standard.

LIMIT
リミッター制御の値
IC301の3ピンの電圧値を5V/255を基準にして表示します。

12. AD CHECK
LIMIT: 255

FAN
Fan control value
The voltage at 4 pin of IC301 is displayed with 5V/255 as a standard.

FAN
ファン制御の値
IC301の4ピンの電圧値を5V/255を基準にして表示します。

12. AD CHECK
FAN: 000

FUN DRIVE	Value
OFF	0
LOW	184
MID	214
HIGH	255

MODEL
Model detection value
(Reference voltage: 5V=255)

MODEL
モデル検出の値
(基準電圧: 5V=255)

12. AD CHECK
MODEL: 129

MODEL	Value
RX-V2600/DSP-AX2600	0
RX-V1600/DSP-AX1600	124
HTR-5990	255

DESTINATION
Destination detection value
(Reference voltage: 5V=255)

DESTINATION
仕向け検出の値
(基準電圧: 5V=255)

12. AD CHECK
DEST: 000

DESTINATION	Value
J	0
U, C	27
R	81
T	102

DESTINATION	Value
K	127
A	152
B, G	208
L	229

PANEL KEY (K0/K1)

(Panel key of main unit) [Remote control code: -]

A/D of the key fails to function properly when the standard value is deviated by ± 8 . In this case, check the constant of partial pressure resistor, solder condition, etc. Refer to table.

(Reference voltage: 5V=255)

PANEL KEY (K0/K1)

(本機パネルキー)

キーのA/Dは基準値から ± 8 を外れると、正常な動きをしません。下表をご覧になり、各キーの分圧抵抗の定数、ハンダ不良等の確認をしてください。

(基準電圧：5V=255)

```
12. AD CHECK
K0:255 K1:255
```

Display	K0	K1
0+4	TONE CONTROL	ZONE CONTROL
26±4	STRAIGHT / EFFECT	A/B/C/D/E
51±4	TUNING MODE	AUDIO SELECT
77±4	MEMORY	SPEAKERS A
104±4	FM/AM	SPEAKERS B
129±4	PRESET/EDIT	PURE DIRECT
154±4	PRESET/TUNING▷	—
179±4	◁ PRESET/TUNING	—
205±4	—	—
230±4	—	—
255	KEY OFF	KEY OFF

13. XM STATUS (U, C models)

The output check of XM Radio Antenna is executed.

1k -1dB/44.1k

The test tone (1kHz, -1dB/44.1kHz) is output.

```
13. XM STATUS
1k - 1dB/44
```

1k -61dB/44.1k

The test tone (1kHz, -61dB/44.1kHz) is output.

```
13. XM STATUS
1k -61dB/44
```

Mute /44.1k

Nothing is output.

```
13. XM STATUS
Mute /44
```

XM Tone/44.1k

The XM tone (44.1kHz) is output.

```
13. XM STATUS
XM Tone/44
```

13. XM STATUS (U, C models)

XM Radio Antennaの出力チェックを行います。

1k -1dB/44.1k

テストトーン(1kHz、-1dB/44.1kHz)を出力します。

1k -61dB/44.1k

テストトーン(1kHz、-61dB/44.1kHz)を出力します。

Mute /44.1k

何も出力されません。

XM Tone/44.1k

XMトーン(44.1kHz)を出力します。

RX-V1600/DSP-AX1600

ISO Tone/44.1k

The ISO tone (44.1kHz) is output.

ISO Tone/44.1k

ISOトーン(44.1kHz) を出力します。

```
13. XM STATUS
ISO Tone/44
```

1k -1dB/32k

The test tone (1kHz, -1dB/32kHz) is output.

1k -1dB/32k

テストトーン(1kHz、-1dB/32kHz) を出力します。

```
13. XM STATUS
1k - 1dB/32
```

1k -61dB/32k

The test tone (1kHz, -61dB/32kHz) is output.

1k -61dB/32k

テストトーン(1kHz、-61dB/32kHz) を出力します。

```
13. XM STATUS
1k -61dB/32
```

Mute /32k

Nothing is output.

Mute /32k

何も出力されません。

```
13. XM STATUS
Mute /32
```

XM Tone/32k

The XM tone (32kHz) is output.

XM Tone/32k

XMトーン(32kHz) を出力します。

```
13. XM STATUS
XM Tone/32
```

ISO Tone/32k

The ISO tone (32kHz) is output.

ISO Tone/32k

ISOトーン(32kHz) を出力します。

```
13. XM STATUS
ISO Tone/32
```

XM/DT Bus Power: OFF

The power of XM module is turned off.

XM/DT Bus Power: OFF

XMモジュールの電源をOFFします。

```
13. XM STATUS
Bus Power:OFF
```

14. IF STATUS (Input function status)

Using the sub-menu, the status data is displayed one after another in the hexadecimal notation.

During signal processing, the status before execution of this menu is maintained.

* Numeric values in the figure example are for reference.

14. IF STATUS

サブメニュー操作により、以下のステータス情報を順次16進数で表示します。信号処理は、本メニュー実行前の状態を維持します。

※ 図中の数値は参考例です。

IS1, 2 (Inside status)

Indicates the status information of the microprocessor.

IS1、2 (内部ステータス)

マイコンのステータス情報を表示します。

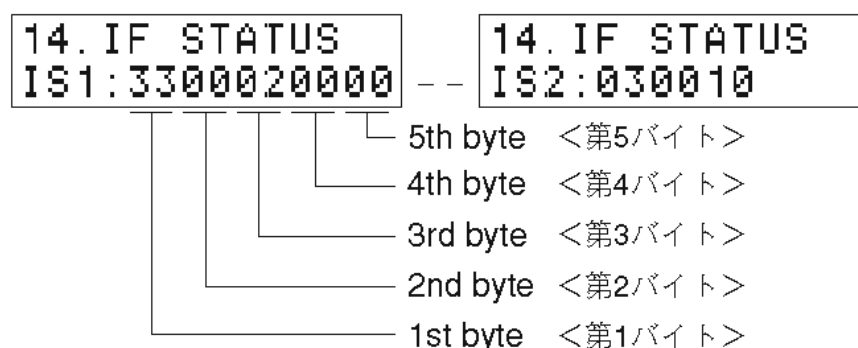

<1st byte> Digital input/output setting value

Upper 4 bits: REC OUT selected /

lower 4 bits: INPUT selected

<第1バイト>デジタル入出力設定値

上位4bit REC OUT選択 /

下位4bit INPUT選択

Value	Choice	Preset name
0	NONE	
1	OPT A	V-AUX
2	OPT B	CD
3	OPT C	DVD
4	OPT D	D-TV
6	OPT F	CBL/SAT
8	COAX A	CD
9	COAX B	DVD
A	COAX C	DVR/VCR2

<2nd byte> Fs information of reproduction signal

<第2バイト>再生信号のFs情報

Display	00	01	02	03	04	05	06	0A	0B	0C	0D
Fs (kHz)	Analog	32	44.1	48	64	88.2	96	Unknown NRM	Unknown DBL	Unknown QUAD	Not defined

<3rd byte> Audio code mode information of reproduction signal

<第3バイト>再生信号のオーディオコードモード情報

Display	00	01	02	03	04	05	06	07	08	09	0A	0B	0C	0D
Audio Code	1+1	1/0	2/0	3/0	2/1	3/1	2/2	3/2	2/3	3/3	OVER 6.1	MULTI PCE	Unknown	Unknown

<4th byte> Format information of reproduction signal

<第4バイト>再生信号のフォーマット情報

*1: Analog processing used for digital reproduction is not possible because of a commercial bit or 4-ch audio reason.

*1: 業務用ビットや4chオーディオなどの理由で、デジタル再生できずアナログ処理されます。

Display	Signal format
00	Analog (Unlock)
01	Incorrect Digital (*1)
10	PCM Audio
20	Digital Data
21	IEC1937 Data
22	None PCM
23	Unknown
50	dts
51	Red dts
54	dts-ES MATRIX
58	dts-ES DISCRETE
5C	dts-ES (Both flag)
60	AAC
C0	Dolby Digital
C1	D.D. Karaoke
C4	D.D.6.1 (D.D.EX)

RX-V1600/DSP-AX1600

<5th byte> Signal processing status information

*2: With digital signals other than 32kHz, 44.1kHz and 48kHz, through processing method is used for reproducible signals.

<第5バイト>信号処理ステータス情報

*2: 32kHz、44.1kHz、48kHz以外のデジタル信号の場合、再生可能な信号についてはスルー処理されます。

bit7	MUTE request	bit3	-
bit6	Red dts flashing	bit2	Through & bypass (*2)
bit5	6.1/EX processing	bit1	-
bit4	FULL MUTE (ON: 1)	bit0	dts analog mute

CS1~3 (Channel status):

Indicates channel status information of the input signal (IEC60958).

CS1~3 (Channel status):

入力信号のIEC60958チャンネルステータス情報を表示します。

14. IF STATUS CS1:FFFFFFFF	-----	14. IF STATUS CS3:FF325400
-------------------------------	-------	-------------------------------

BS1~10: Indicates information of the bit stream included in the dts and Dolby Digital signals.

BS1~10: dts、Dolby Digital、AAC信号に含まれるビットストリームインフォメーション情報を表示します。

14. IF STATUS BS1:0000000000	-----	14. IF STATUS BS10:000000
---------------------------------	-------	------------------------------

TI1~2:

TI1~2:

14. IF STATUS TI1:0808000600	-----	14. IF STATUS TI2:00
---------------------------------	-------	-------------------------

MTT: Mute Trigger

MTT: Mute Trigger

14. IF STATUS MTT:00180018FF

Byte No.	Function
1	Mute condition
2	Factor of the last mute
3	Error count of YSS930-FSCNT
4	Mute count by YSS930-FSCNT
5	Error factor of down load of CS49329

15. PROTECTION SETTING

Not applied to this model.

PS_Lo:

```
15. PROTECTION
PS_Lo: 0076
```

PS_Hi:

```
15. PROTECTION
PS_Hi: 0106
```

DC_Lo:

```
15. PROTECTION
DC_Lo: 0003
```

DC_Hi:

```
15. PROTECTION
DC_Hi: 0033
```

FAN_0~5:

```
15. PROTECTION 15. PROTECTION
FAN_0: 0063 ----- FAN_5: 0069
```

TEMP:

```
15. PROTECTION
TEMP : 0090
```

PL_8_M_L:

```
15. PROTECTION
PL_8_M_L:0160
```

```
15. PROTECTION
PL_8_M_H:0189
```

```
15. PROTECTION
PL_8_N_L:0160
```

```
15. PROTECTION
PL_8_N_H:0189
```

```
15. PROTECTION
PL_6_M_L:0150
```

```
15. PROTECTION
PL_6_M_H:0180
```

```
15. PROTECTION
PL_6_N_L:0150
```

```
15. PROTECTION
PL_6_N_H:0180
```

15. PROTECTION SETTING

このモデルには適用されません。

PS_Lo:

PS_Hi:

DC_Lo:

DC_Hi:

FAN_0~5:

TEMP:

PL_8_M_L:

RX-V1600/DSP-AX1600

16. PROTECTION HIST.

The history of protection function is displayed.
After selecting the sub-menu, press the "STRAIGHT" key, and the history will be erased.

16. PROTECTION HIST.

プロテクション履歴を表示します。
サブメニューを選んだ後、“STRAIGHT”キーを押すと履歴は消去されます。

Last

```
16. PROTE HIST.
LAST:
```

Last

History1

```
16. PROTE HIST.
HIST1:
```

History1

History2

```
16. PROTE HIST.
HIST2
```

History2

History3

```
16. PROTE HIST.
HIST3:
```

History3

17. DSP CHECK

Whether the bus of DSP P.C.B. is connected properly or not is self-diagnosed.

17. DSP CHECK

DSP P.C.B.のバス接続の正否を自己診断します。

TI BUS

TI (IC512) data bus check is executed.

TI BUS

TI (IC512)のデータバスチェックを行います。

```
17. DSP CHECK
TI BUS:NoEr
```

YSS-930 BUS

YSS-930 (IC516, IC518) data bus check is executed.

YSS-930 BUS

YSS-930 (IC516、IC518)のデータバスチェックを行います。

```
17. DSP CHECK
YSS BUS:NoEr
```

Display	Description
WAIT	Bus is being checked.
NoEr	No error detected.
DATA	Data bus shorted or open.
RSCS	/RAS or /CAS shorted, or open.
ADDR	Address bus shorted or open.

表示	判断
WAIT	バスチェック中
NoEr	不良検出なし
DATA	データバスの短絡・解放
RSCS	/RASまたは/CASの短絡・解放
ADDR	アドレスバスの短絡・解放

18. D-VIDEO CHECK

Whether the bus of D-VIDEO P.C.B. is connected properly or not is self-diagnosed.

ALL Check

The synthetic judgment result is displayed.

- OK : No error detected
- NG : An error is detected
- No Check : Detection is not executed

```
18. DVIDEO CHK
ALL:OK
```

Microprocessor/Flash Check

The data bus check of Microprocessor (IC501) and Flash (IC507) is executed.

- OK : No error detected
- NG : An error is detected

```
18. DVIDEO CHK
M:OK F:OK
```

I2C Read Check

The Line check of I2C is executed.

- OK : 0
- NG : 1

```
18. DVIDEO CHK
I2C:00000000
```

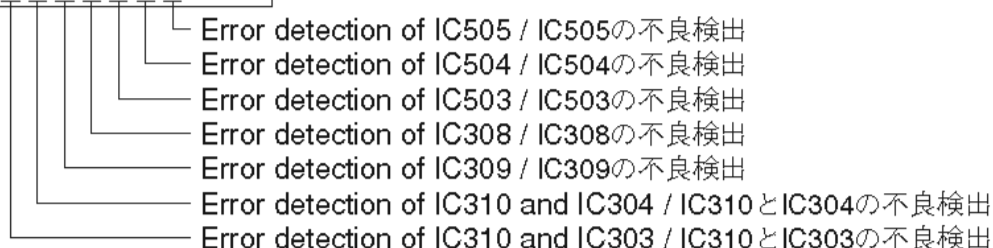

YGV BUS Check

Not applied to this model.

```
18. DVIDEO CHK
YGV:NoError
```

18. D-VIDEO CHECK

D-VIDEO P.C.B.のバス接続の正否を自己診断します。

ALL Check

総合判定結果を表示します。

- OK : 不良検出なし
- NG : 不良検出あり
- No Check : 未検出

Microprocessor/Flash Check

Microprocessor (IC501) とFlash (IC507) のデータバスチェックを行います。

- OK : 不良検出なし
- NG : 不良検出あり

I2C Read Check

I2Cラインのチェックを行います。

- OK : 0
- NG : 1

YGV BUS Check

このモデルには適用されません。

19. HDMI INFORMATION

HDMI Model Name

The model name of this unit written in HDMI module is displayed.

- RX-V1600 (U, C, R, T, K, A, B, G, L models)
- DSP-AX1600 (J model)

```
19. HDMI INFO
HMN:DSP-AX1600
```

19. HDMI INFORMATION

HDMI Model Name

HDMIモジュールに書き込まれている本機のモデル名を表示します。

- RX-V1600 (U, C, R, T, K, A, B, G, L models)
- DSP-AX1600 (J model)

RX-V1600/DSP-AX1600

HDMI Product ID

The product ID of this unit written in HDMI module is displayed.

3105 (U, C, R, T, K, A, B, G, L models)
3104 (J model)

HDMI Product ID

HDMIモジュールに書き込まれている本機のプロダクトIDを表示します。

3105 (U, C, R, T, K, A, B, G, L models)
3104 (J model)

```
19.HDMI INFO
HPI:3104
```

HDMI Vendor Name

The vendor name (YAMAHA) of this unit written in the HDMI module is displayed.

HDMI Vendor Name

HDMIモジュールに書き込まれている本機のベンダ名 (YAMAHA) を表示します。

```
19.HDMI INFO
HVN:YAMAHA
```

20. HDMI SELECT**HDMI NONE: No Connect**

Neither HDMI IN 1 terminal nor HDMI IN 2 terminal is selected for input.

20. HDMI SELECT**HDMI NONE: No Connect**

HDMI IN 1端子とHDMI IN 2端子のどちらも入力セレクトしません。

```
20.HDMI SELECT
HDMI NONE
```

HDMI IN 1: HDMI IN 1 Port

The HDMI device connected to HDMI IN 1 terminal is selected for input and HDMI is reproduced.

With the audio input terminal selection set to HDMI (Fix), SPDIF or I2S is selected automatically according to the audio format which is used for HDMI input.

Support Audio is set to "others".

HDMI IN 1: HDMI IN 1 Port

HDMI IN 1端子に接続したHDMI機器を入力セレクトして、HDMI再生します。

音声入力端子切替は、HDMI(Fix)に設定し、HDMI入力した音声フォーマットに従ってSPDIFとI2Sを自動で切り替えます。

対応音声(Support Audio)を、その他の機器(others)に設定します。

```
20.HDMI SELECT
HDMI IN 1
```

HDMI IN 2: HDMI IN 2 Port

The HDMI device connected to HDMI IN 2 terminal is selected for input and HDMI is reproduced.

With the audio input terminal selection set to HDMI (Fix), SPDIF or I2S is selected automatically according to the audio format which is used for HDMI input.

Support Audio is set to "others".

HDMI IN 2: HDMI IN 2 Port

HDMI IN 2端子に接続したHDMI機器を入力セレクトして、HDMI再生します。

音声入力端子切替は、HDMI(Fix)に設定し、HDMI入力した音声フォーマットに従ってSPDIFとI2Sを自動で切り替えます。

対応音声(Support Audio)を、その他の機器(others)に設定します。

```
20.HDMI SELECT
HDMI IN 2
```

21. HDMI UPCONV

The image signal is converted and output to HDMI OUT as follows.

HDMI Decoder

21. HDMI UPCONV

映像信号が以下のように変換され、HDMI OUTに出力されます。

HDMI Decoder

21. HDMI UPCONV
HDMI DECODER

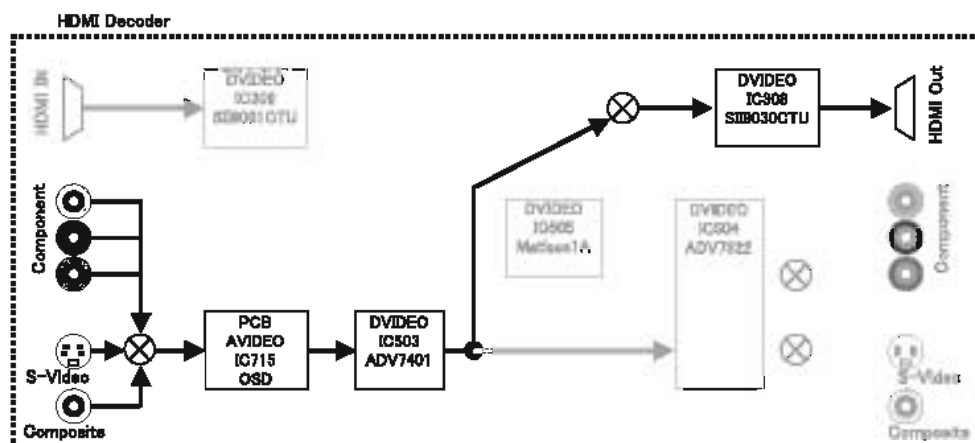

HDMI YGV

Not applied to this model.

HDMI YGV

このモデルには適用されません。

21. HDMI UPCONV
HDMI YGV

HDMI I/P

HDMI I/P

21. HDMI UPCONV
HDMI I/P

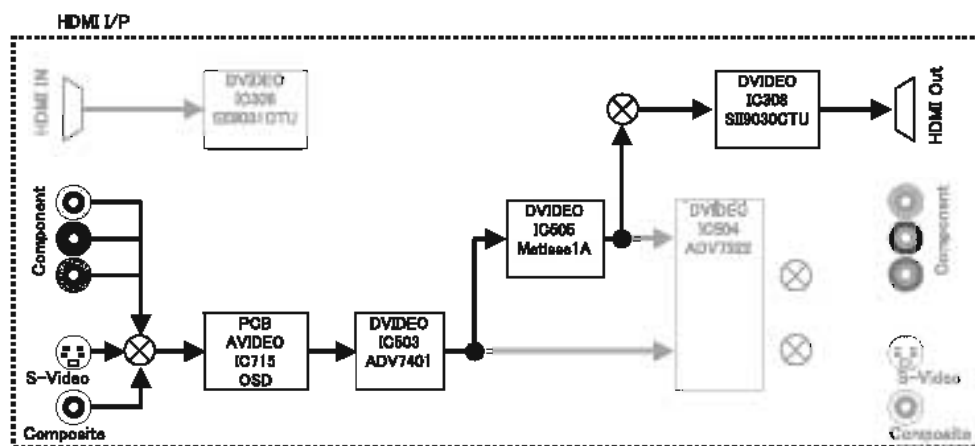

HDMI 720p

Not applied to this model.

HDMI 720p

このモデルには適用されません。

21. HDMI UPCONV
*HDMI 720P

HDMI 1080i

Not applied to this model.

HDMI 1080i

このモデルには適用されません。

21. HDMI UPCONV
*HDMI 1080i

RX-V1600/DSP-AX1600

22. VIDEO

The image signal is converted and output as follows.

DIGITAL THR COMP

22. VIDEO
DIGITAL COMP

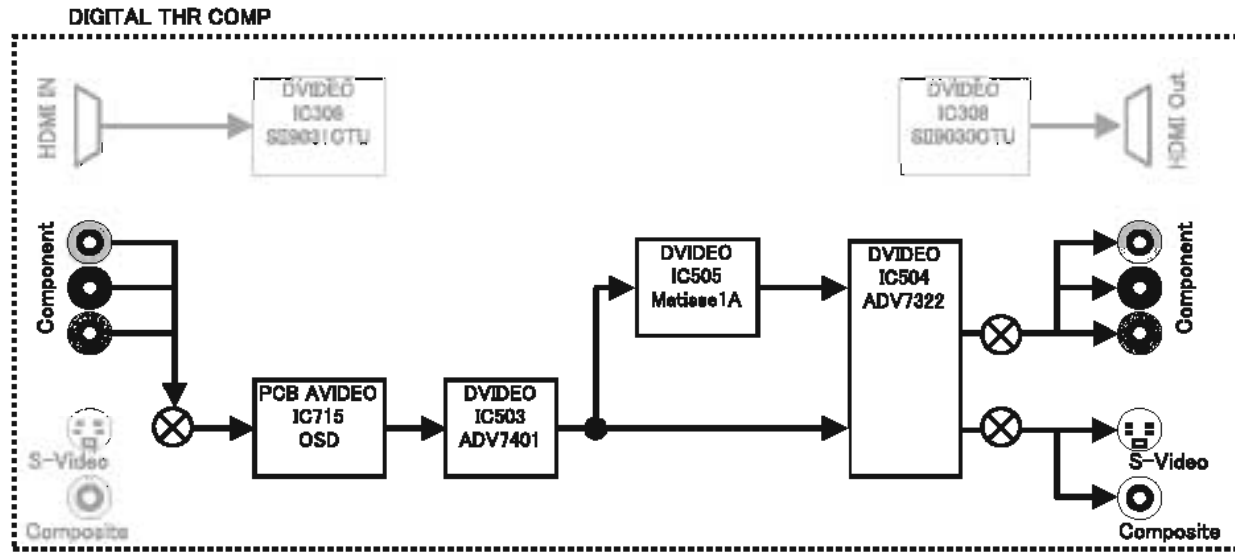

DIGITAL THR CVBS

22. VIDEO
DIGITAL CVBS

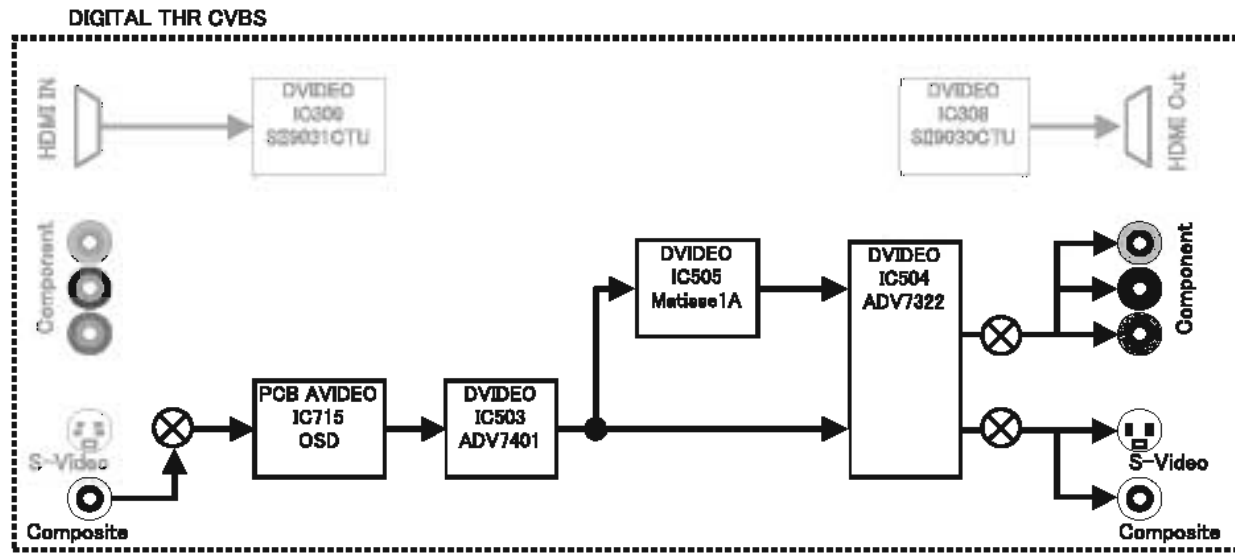

DIGITAL THR Y/C

22. VIDEO
DIGITAL Y/C

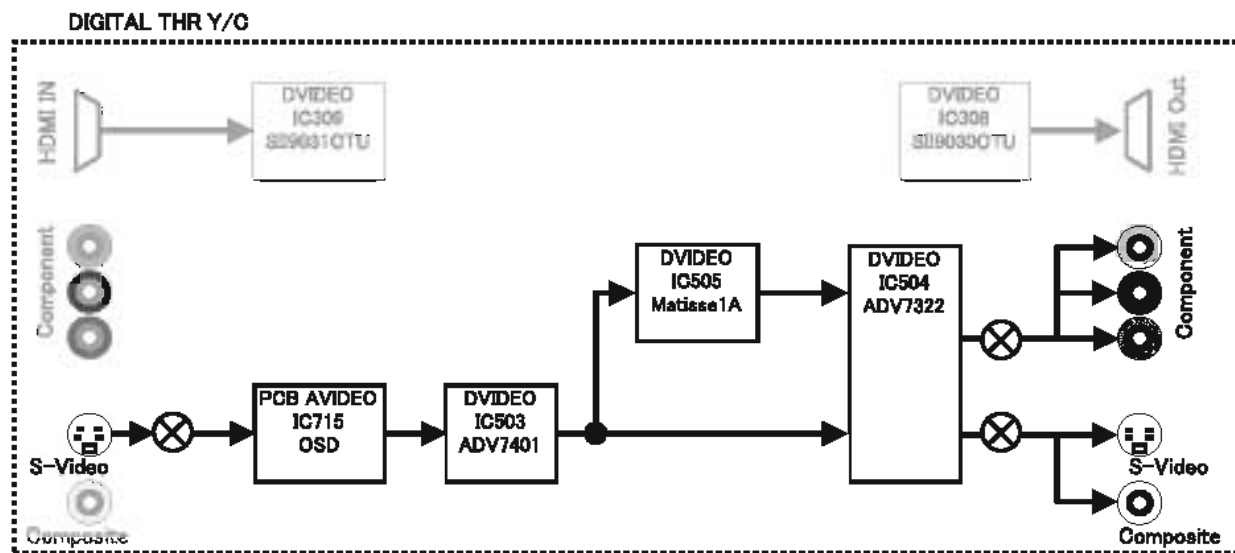

22. VIDEO

映像信号が以下のように変換され、出力されます。

DIGITAL THR COMP

DIGITAL THR CVBS

DIGITAL THR Y/C

DIGITAL BYPASS

DIGITAL BYPASS

22. VIDEO
DIGITAL BYPASS

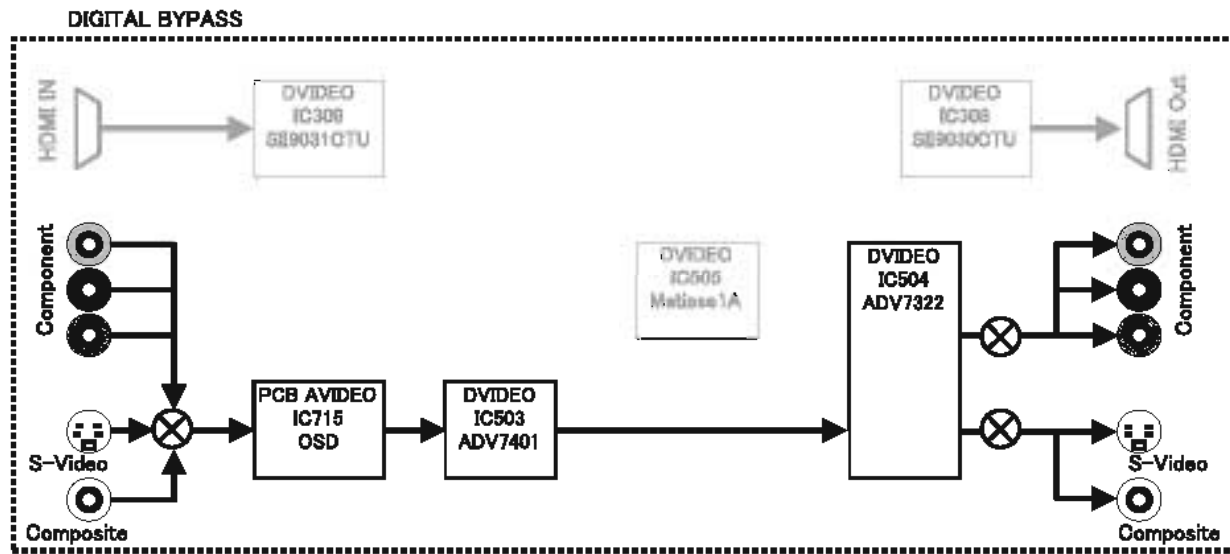

ANALOG BYPASS

ANALOG BYPASS

22. VIDEO
ANALOG BYPASS

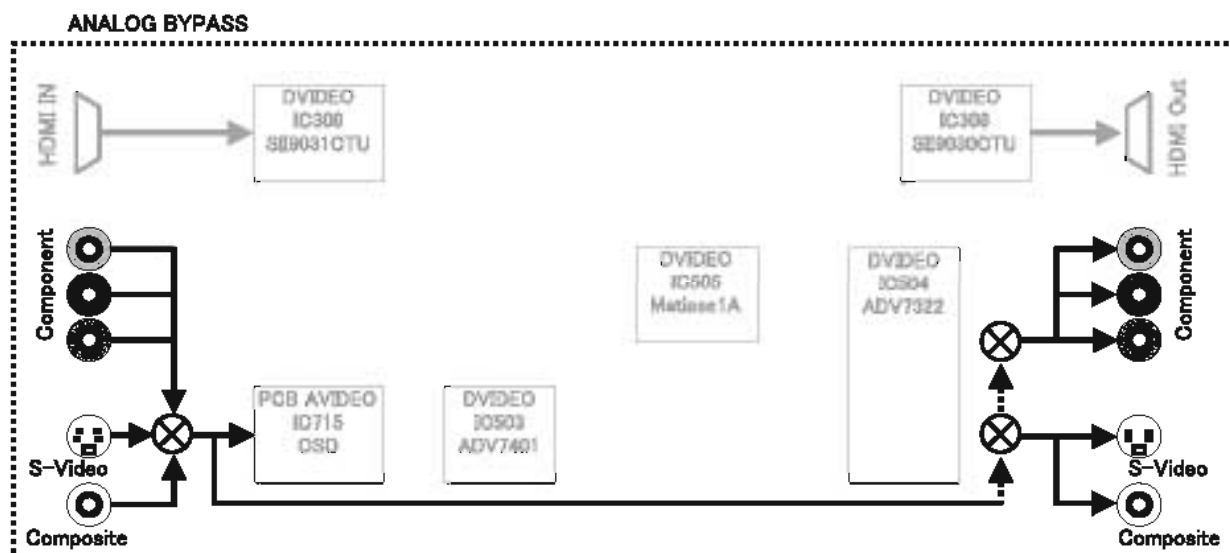

TEST PATTERN 1

TEST PATTERN 1

22. VIDEO
TEST PATTERN 1

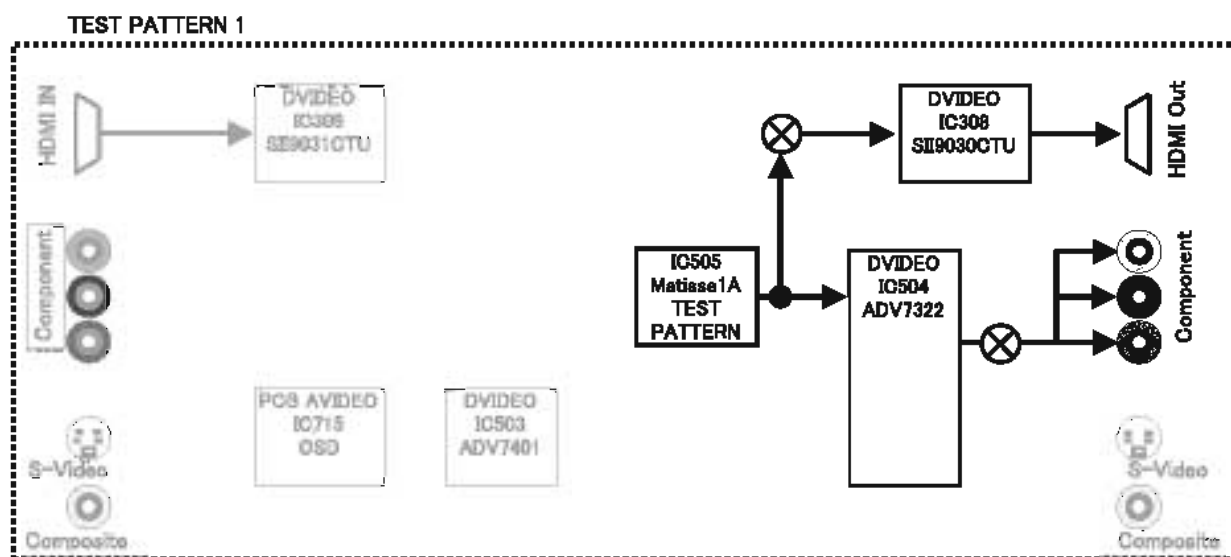

IC505 TEST Pattern (480p/576p)

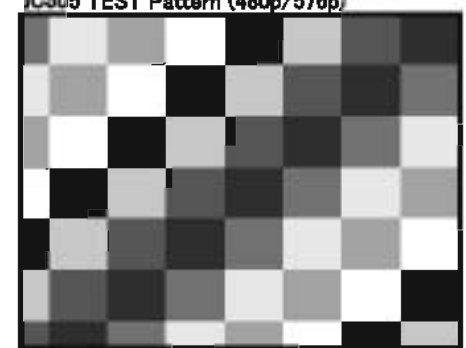

RX-V1600/DSP-AX1600

TEST PATTERN 2

TEST PATTERN 2

22. VIDEO
TEST PATTERN 2

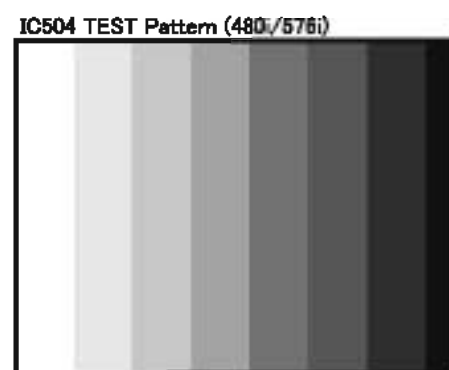
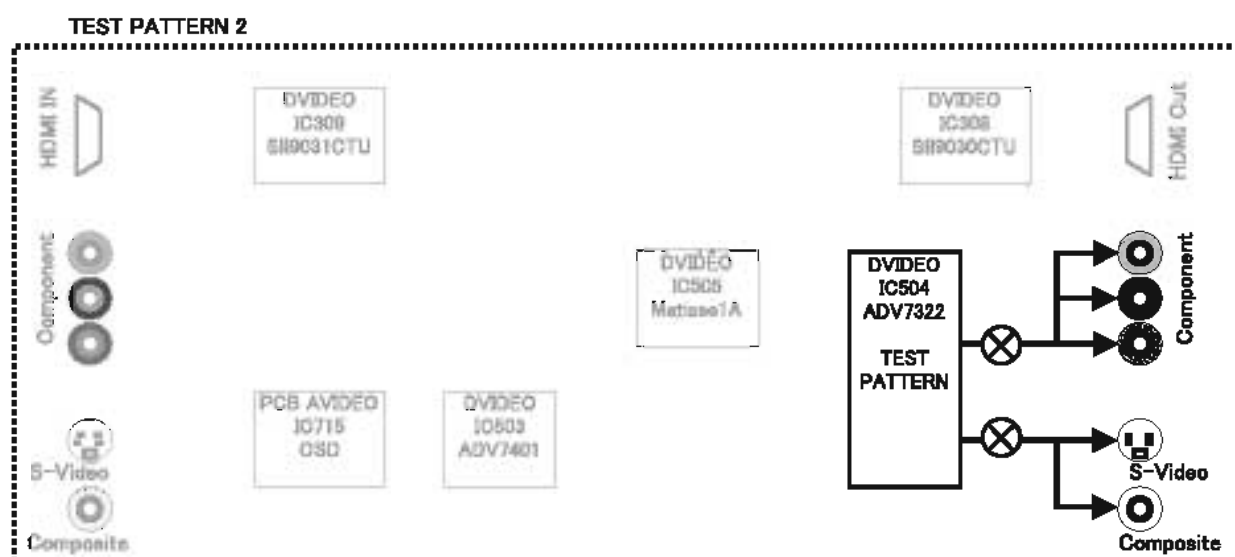

VIDEO INFO

VIDEO INFO

22. VIDEO
VIDEO INFO

23. BUS CHECK

Not applied to this model.

23. BUS CHECK

このモデルには適用されません。

TI FLASH READ

TI FLASH READ

23. BUS CHECK
TI FLASH R

TI FLASH WRITE

TI FLASH WRITE

23. BUS CHECK
TI FLASH W

TI SDRAM READ

TI SDRAM READ

23. BUS CHECK
TI SDRAM R

TI SDRAM WRITE

TI SDRAM WRITE

23. BUS CHECK
TI SDRAM W

YGV READ

YGV READ

23. BUS CHECK
YGV BUS R

YGV WRITE

YGV WRITE

23. BUS CHECK
YGV BUS W

24. FLASH 232C

Select this when writing the firmware.

MAIN

Writing of MAIN.

```
24. FLASH 232C
MAIN
```

VIDEO

Writing of VIDEO.

```
24. FLASH 232C
VIDEO
```

TI

Writing of DSP.

```
24. FLASH 232C
TI
```

24. FLASH 232C

ファームウェアの書き込み時に選択します。

MAIN

MAINの書き込み。

VIDEO

VIDEOの書き込み。

TI

DSPの書き込み。

25. SET INFO

The information on the model and destination is displayed.

MODEL: V1600

```
25. SET INFO
MODEL: V1600
```

DEST.: J, UC, R, T, K, A, BG, L

J, UC, R, T, K, A, BG or L is displayed.

```
25. SET INFO
DEST.: J
```

25. SET INFO

モデル、仕向けの情報を表示します。

MODEL: V1600

DEST.: J, UC, R, T, K, A, BG, L

J, UC, R, T, K, A, BG, Lのいずれかを表示します。

26. SOFT SW

This menu is used to switch the function settings on P.C.B. through the software so as to activate the product.

The protection function follows the P.C.B. settings. When connected to AC or in the maker preset state, the unit is initialized to the P.C.B. setting. Display of each function after initialization varies depending on settings on P.C.B.. The operation mode can be changed by selecting the sub-menu and then using the "STRAIGHT" key.

SW MODE: PCB/SOFT

PCB or SOFT can be selected.

```
26. SOFT SW
SW MODE : PCB
```

26. SOFT SW

P.C.B.上の機能設定をソフト的に切り替えて、製品を動作させる機能です。

プロテクション機能は、P.C.B.の設定に従います。AC接続またはメーカープリセットで、P.C.B.の設定に初期化されます。初期化後の各機能の表示は、P.C.B.上の設定によります。操作は、サブメニューを選んだ後、“STRAIGHT”キーで切り替えます。

SW MODE: PCB/SOFT

PCBまたはSOFTを選択できます。

RX-V1600/DSP-AX1600

VIDEO FORMAT: NTSC/PAL

NTSC or PAL can be selected.
 NTSC (U, C, R, K, J models)
 PAL (T, A, B, G, L models)

VIDEO FORMAT: NTSC/PAL

NTSC、PALいずれかを選択できます。
 NTSC (U、C、R、K、J models)
 PAL (T、A、B、G、L models)

26. SOFT SW
TV FORMAT:

AAC EXIST: EXIST/NOT

EXIST or NOT can be selected.
 EXIST (J model)
 NOT (U, C, R, T, K, A, B, G, L models)

AAC EXIST: EXIST/NOT

EXIST、NOTいずれかを選択できます。
 EXIST (J model)
 NOT (U、C、R、T、K、A、B、G、L models)

26. SOFT SW
AAC:

CSII EXIST: EXIST/NOT

EXIST or NOT can be selected.
 EXIST (J model)
 NOT (U, C, R, T, K, A, B, G, L models)

CSII EXIST: EXIST/NOT

EXIST、NOTいずれかを選択できます。
 EXIST (J model)
 NOT (U、C、R、T、K、A、B、G、L models)

26. SOFT SW
CSII:

RDS EXIST: EXIST/NOT

EXIST or NOT can be selected.
 EXIST (B, G models)
 NOT (U, C, R, T, K, A, L, J models)

RDS EXIST: EXIST/NOT

EXIST、NOTいずれかを選択できます。
 EXIST (B、G models)
 NOT (U、C、R、T、K、A、L、J models)

26. SOFT SW
RDS:

XM EXIST: EXIST/NOT

EXIST or NOT can be selected.
 EXIST (U, C models)
 NOT (R, T, K, A, B, G, L, J models)

XM EXIST: EXIST/NOT

EXIST、NOTいずれかを選択できます。
 EXIST (U、C models)
 NOT (R、T、K、A、B、G、L、J models)

26. SOFT SW
XM:

TMP TEST J/UC/RL

J, UC or RL can be selected.
 J (J model)
 UC (U, C, T, K, A, B, G models)
 RL (R, L models)

TMP TEST J/UC/RL

J、UC、RLいずれかを選択できます。
 J (J model)
 UC (U、C、T、K、A、B、G models)
 RL (R、L models)

26. SOFT SW
TMP TEST J

27. ROM VER/SUM

The version and checksum are displayed. The signal is processed using EFFECT OFF. The checksum is obtained by adding the data at every 8 bits for each program area and expressing the result as a 4-figure hexadecimal data.

27. ROM VER/SUM

プログラムのバージョン、チェックサムを表示します。信号はエフェクトOFFです。チェックサムは、プログラムエリア別にデータを8ビットごとに加算していき、4桁の16進データで現したものです。



■ AMP ADJUSTMENT / アンプ部調整

Confirmation of Idling Current of Amp

Unit

- Right after power is turned on, confirm that the voltage across the terminals of R319 (MAIN Lch), R320 (MAIN Rch), R325 (CENTER), R326 (SURROUND Lch), R327 (SURROUND Rch), R321 (SURROUND BACK Lch), R322 (SURROUND BACK Rch) are between 0.1mV and 10.0mV.
- If it exceeds 10.0mV, open (cutoff) R291 (MAIN Lch), R292 (MAIN Rch), R295 (CENTER), R296 (SURROUND Lch), R297 (SURROUND Rch), R293 (SURROUND BACK Lch), R294 (SURROUND BACK Rch) and reconfirm the voltage.

Attention

If the idle current exceeds 10.0mV after an amplifier repair, first check for a defective component before cutting the bias resistor.

- Confirm that the voltage is 0.2 mV ~ 15.0 mV after 60 minutes.

アンプユニットのアイドリング電流の確認

- 電源投入直後、R319 (MAIN Lch)、R320 (MAIN Rch)、R325 (CENTER)、R326 (SURROUND Lch)、R327 (SURROUND Rch)、R321 (SURROUND BACK Lch)、R322 (SURROUND BACK Rch)の端子間電圧を測定し、0.1mVから10.0mVの間であることを確認してください。
- 電圧が10mVを超えている場合は、R291 (MAIN Lch)、R292 (MAIN Rch)、R295 (CENTER)、R296 (SURROUND Lch)、R297 (SURROUND Rch)、R293 (SURROUND BACK Lch)、R294 (SURROUND BACK Rch)をカットし、電圧を再確認してください。

注意

パワーアンプ修理後に10.0mVを超えている場合は、抵抗をカットする前に故障箇所を調べてください。

- 60分後、電圧が0.2mV～15.0mVであることを確認してください。

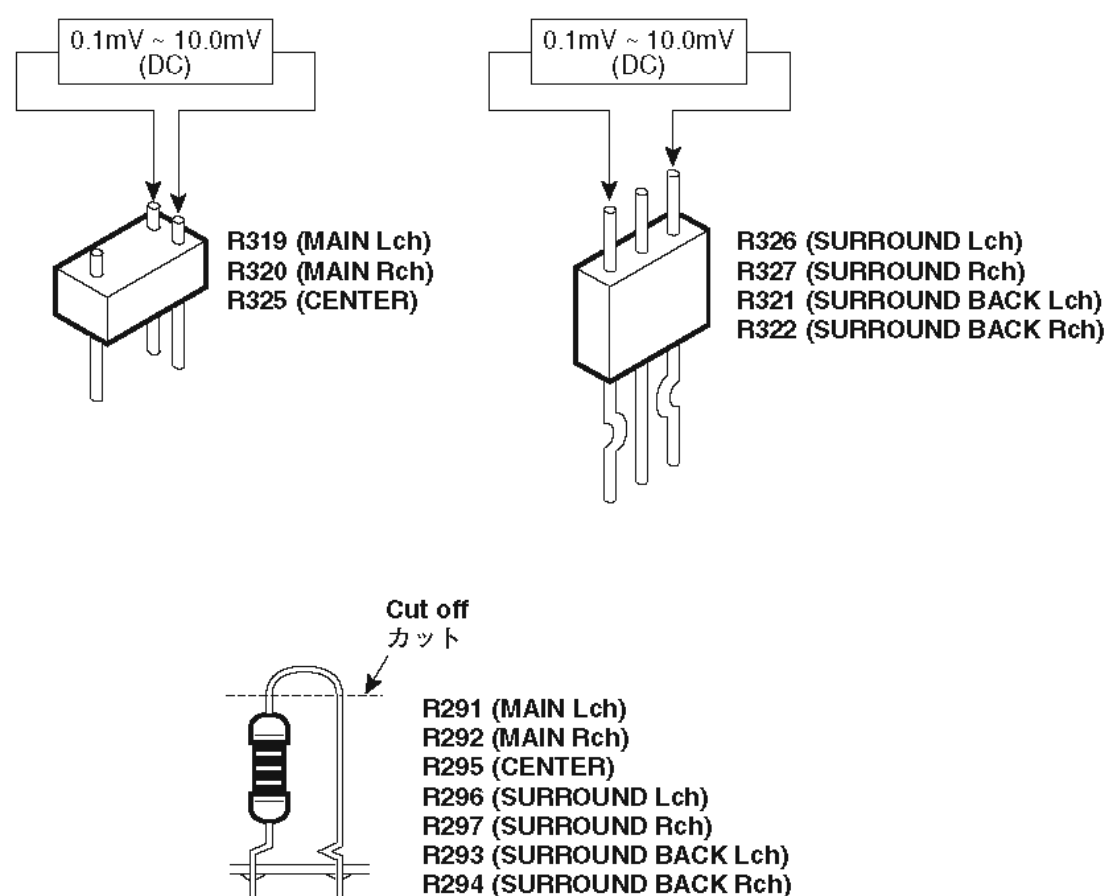

REAR

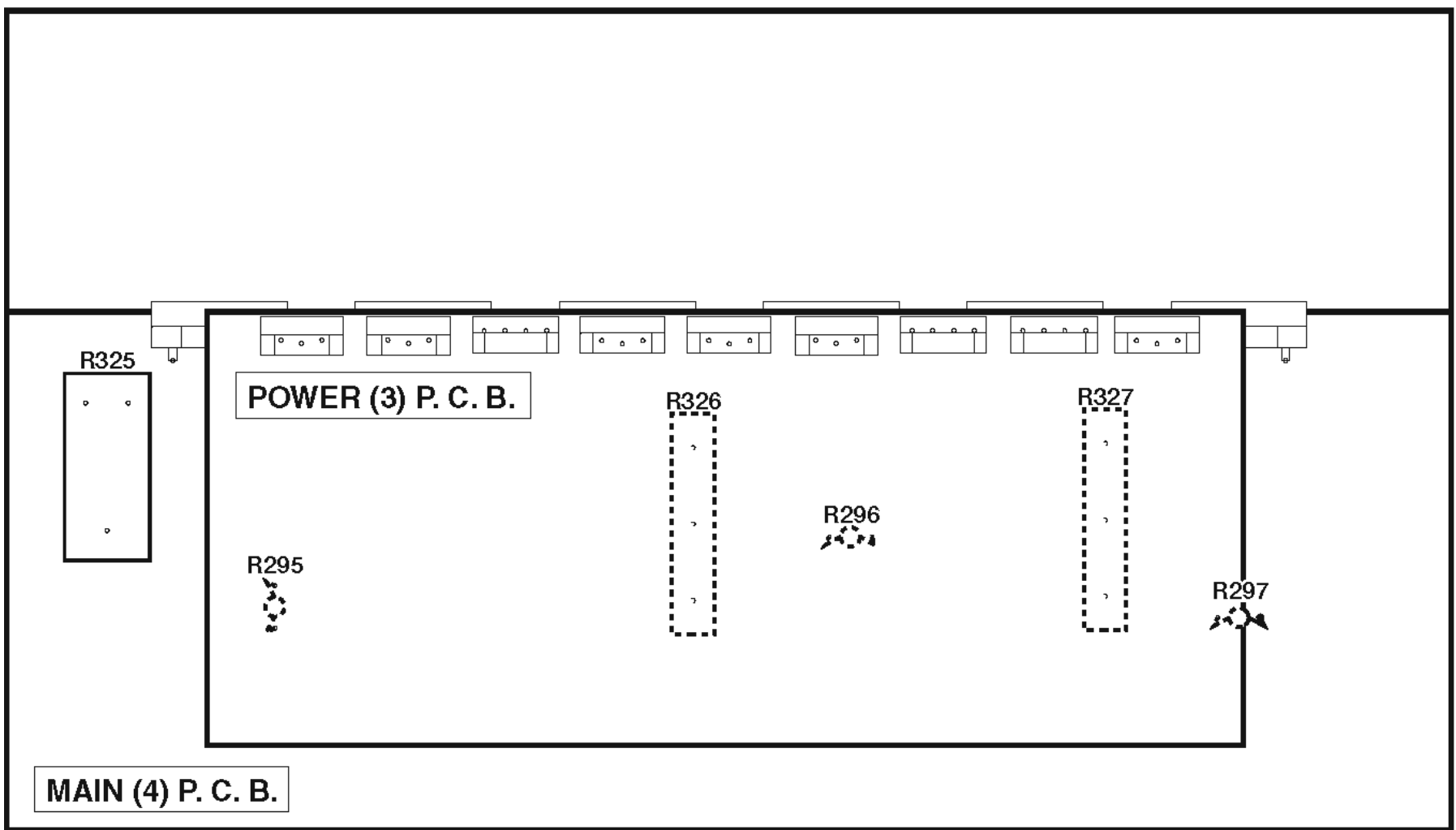
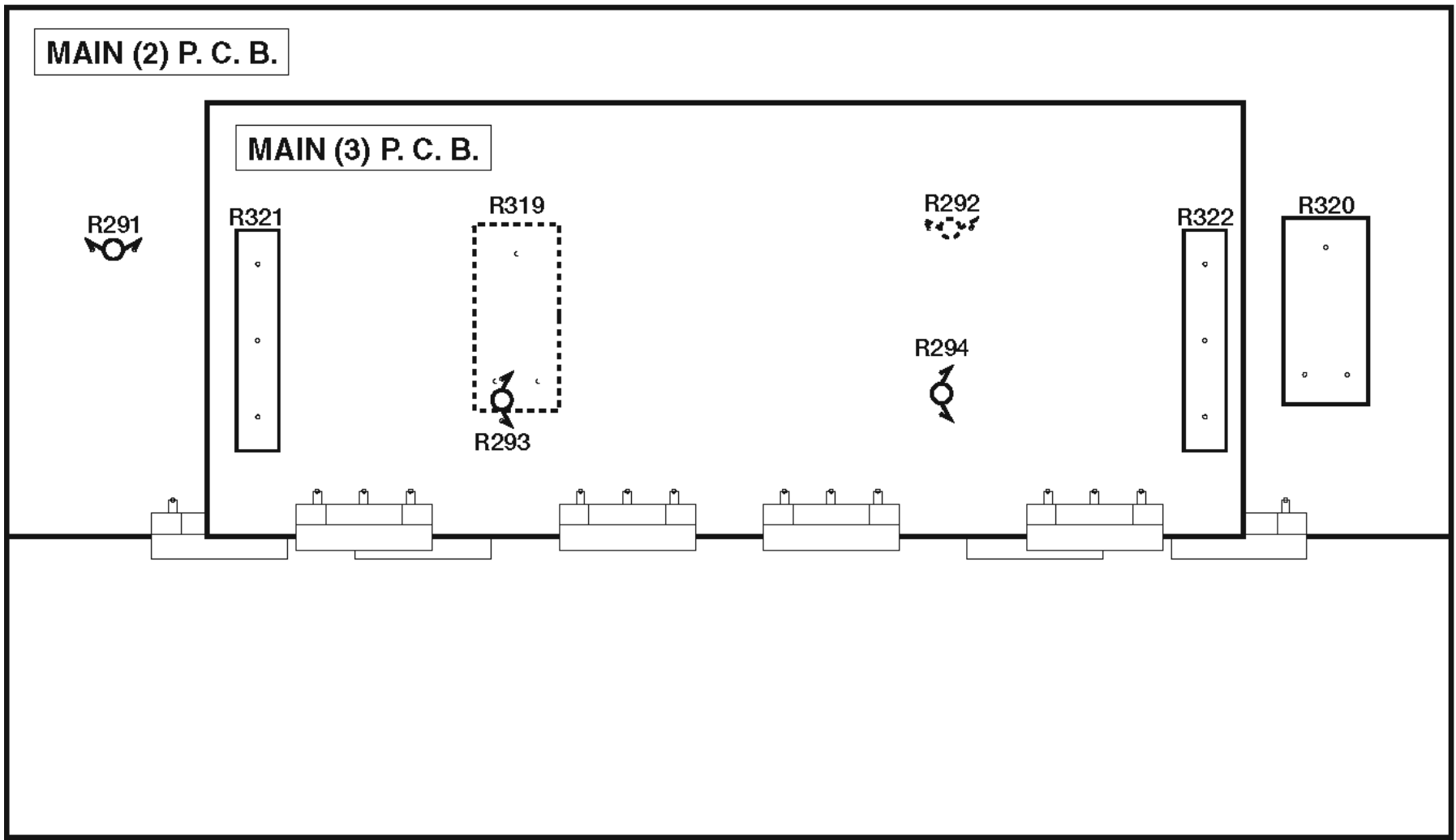

FRONT

DISPLAY DATA

● V600 : HNA-16ML10T (WF875800)

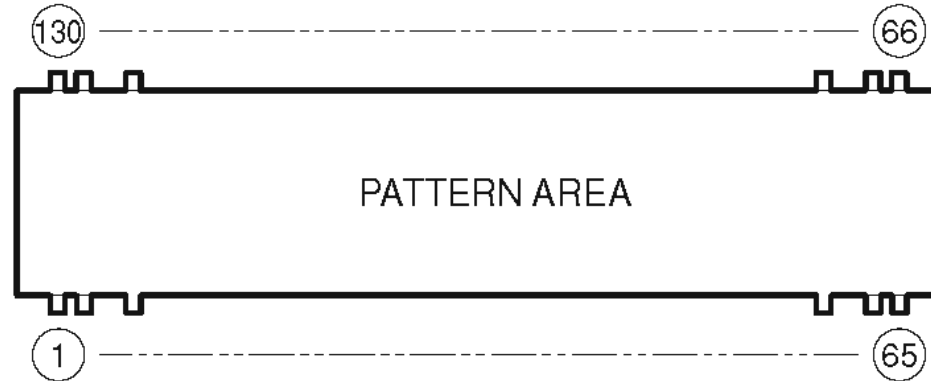

PIN CONNECTION

Pin No.	130	129	128	127	126	125	124	123	122	121	120	119	118	117	116	115	114	113	112	111	110	109	108	107	106	105	104	103	102	101	100	99	
Connection	F1	F1	NP	NP	P	P	P	P	P	P	P	P	P	P	P	P	P	P	P	P	P	P	P	P	P	P	P	P	P	P	P	P	
					35A	34A	33A	32A	31A	30A	29A	28A	27A	26A	25A	24A	23A	22A	21A	20A	19A	18A	17A	16A	15A	14A	13A	12A	11A	10A	9A	8A	
Pin No.	98	97	96	95	94	93	92	91	90	89	88	87	86	85	84	83	82	81	80	79	78	77	76	75	74	73	72	71	70	69	68	67	66
Connection	P	P	P	P	P	P	P	NX	NX	NX	NX	NX	16	15	14	13	12	11	10	9	8	7	6	5	4	3	2	1	NP	NP	F2	F2	
	7A	6A	5A	4A	3A	2A	1A						G	G	G	G	G	G	G	G	G	G	G	G	G	G	G	G					
Pin No.	34	35	36	37	38	39	40	41	42	43	44	45	46	47	48	49	50	51	52	53	54	55	56	57	58	59	60	61	62	63	64	65	
Connection	P	P	P	P	P	P	P	P	P	P	P	P	P	P	P	P	P	P	P	P	P	P	P	P	P	P	P	P	NP	NP	F2	F2	
	8B	9B	10B	11B	12B	13B	14B	15B	16B	17B	18B	19B	20B	21B	22B	23B	24B	25B	26B	27B	28B	29B	30B	31B	32B	33B	34B	35B					
Pin No.	1	2	3	4	5	6	7	8	9	10	11	12	13	14	15	16	17	18	19	20	21	22	23	24	25	26	27	28	29	30	31	32	33
Connection	F1	F1	NP	NP	1	2	3	4	5	6	7	8	9	10	11	12	13	14	15	NX	NX	NX	NX	NX	NX	NX	P	P	P	P	P	P	
					GB	GB	GB	GB	GB	GB	GB	GB	GB	GB	GB	GB	GB	GB	GB								1B	2B	3B	4B	5B	6B	7B

Note: 1) F1, F2 Filament pin 2) 1GA~16GA, 1GB~15GB Grid pin 3) P1A~P35A, P1B~P35B Anode pin 4) NP No pin 5) NX No extended pin

GRID ASSIGNMENT

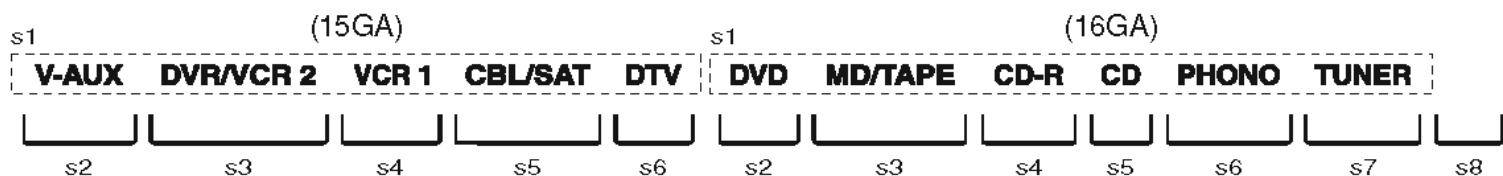
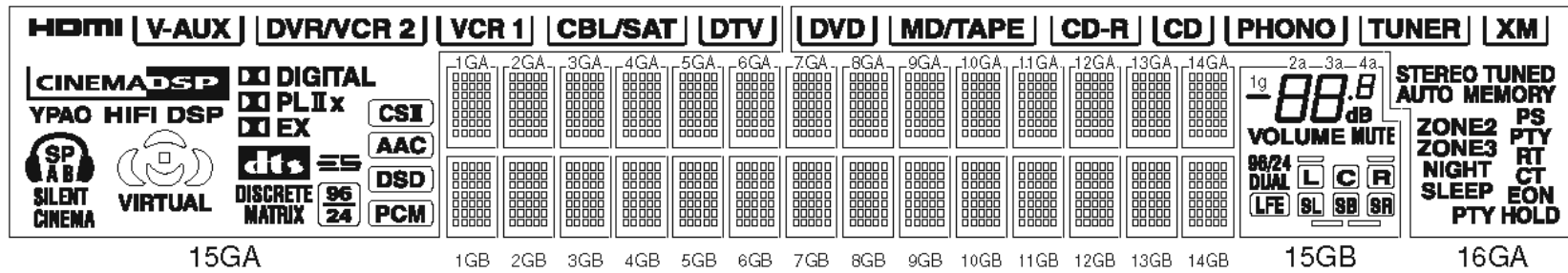

(1GA~14GA, 1GB~14GB)

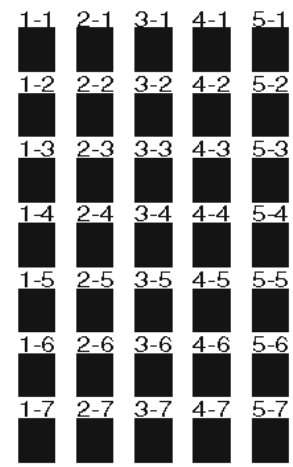







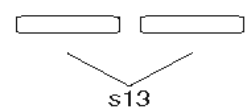
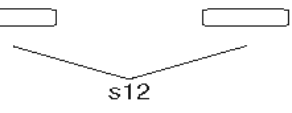



(15GA)









(15GB)



● ANODE CONNECTION

	1GA~14GA	15GA	16GA
P1A	1-1	HDMI	s1
P2A	2-1	s1	s2
P3A	3-1	s2	s3
P4A	4-1	s3	s4
P5A	5-1	s4	s5
P6A	1-2	s5	s6
P7A	2-2	s6	s7
P8A	3-2	CINEMA DSP	s8
P9A	4-2	YPAO	STEREO
P10A	5-2	HIFI DSP	TUNED
P11A	1-3		AUTO
P12A	2-3	SP	MEMORY
P13A	3-3	A	ZONE2
P14A	4-3	B	ZONE3
P15A	5-3	SILENT CINEMA	NIGHT
P16A	1-4	s7	SLEEP
P17A	2-4	s8	PS
P18A	3-4	s9	PTY
P19A	4-4	s10	RT
P20A	5-4	VIRTUAL	CT
P21A	1-5	 DIGITAL	EON
P22A	2-5	 PL	PTY HOLD
P23A	3-5	II	XM
P24A	4-5	x	
P25A	5-5	 EX	
P26A	1-6		
P27A	2-6		
P28A	3-6	DISCRETE	
P29A	4-6	MATRIX	
P30A	5-6		
P31A	1-7		
P32A	2-7		
P33A	3-7		
P34A	4-7		
P35A	5-7		

	1GB~14GB	15GB
P1B	1-1	1g
P2B	2-1	2a
P3B	3-1	2b
P4B	4-1	2c
P5B	5-1	2d
P6B	1-2	2e
P7B	2-2	2f
P8B	3-2	2g
P9B	4-2	3a
P10B	5-2	3b
P11B	1-3	3c
P12B	2-3	3d
P13B	3-3	3e
P14B	4-3	3f
P15B	5-3	3g
P16B	1-4	4a
P17B	2-4	4b
P18B	3-4	4c
P19B	4-4	4d
P20B	5-4	4e
P21B	1-5	4f
P22B	2-5	4g
P23B	3-5	s11
P24B	4-5	MUTE
P25B	5-5	96/24
P26B	1-6	DUAL
P27B	2-6	
P28B	3-6	
P29B	4-6	
P30B	5-6	
P31B	1-7	
P32B	2-7	
P33B	3-7	
P34B	4-7	s12
P35B	5-7	s13

IC DATA

IC301: M30845FJGP (FUNCTION P.C.B)
16-bit Microprocessor

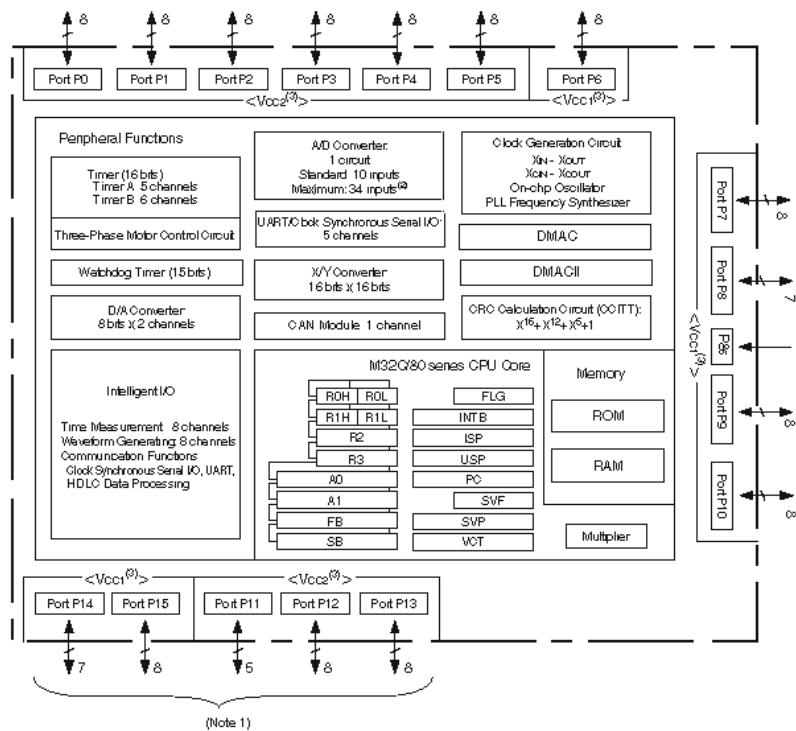

NOTES
 1. Ports P11 to P15 are provided in the 144-pin package only.
 2. Included in the 144-pin package only.
 3. The supply voltage of M32C/84T (High-reliability version) must be Vcc1=Vcc2.

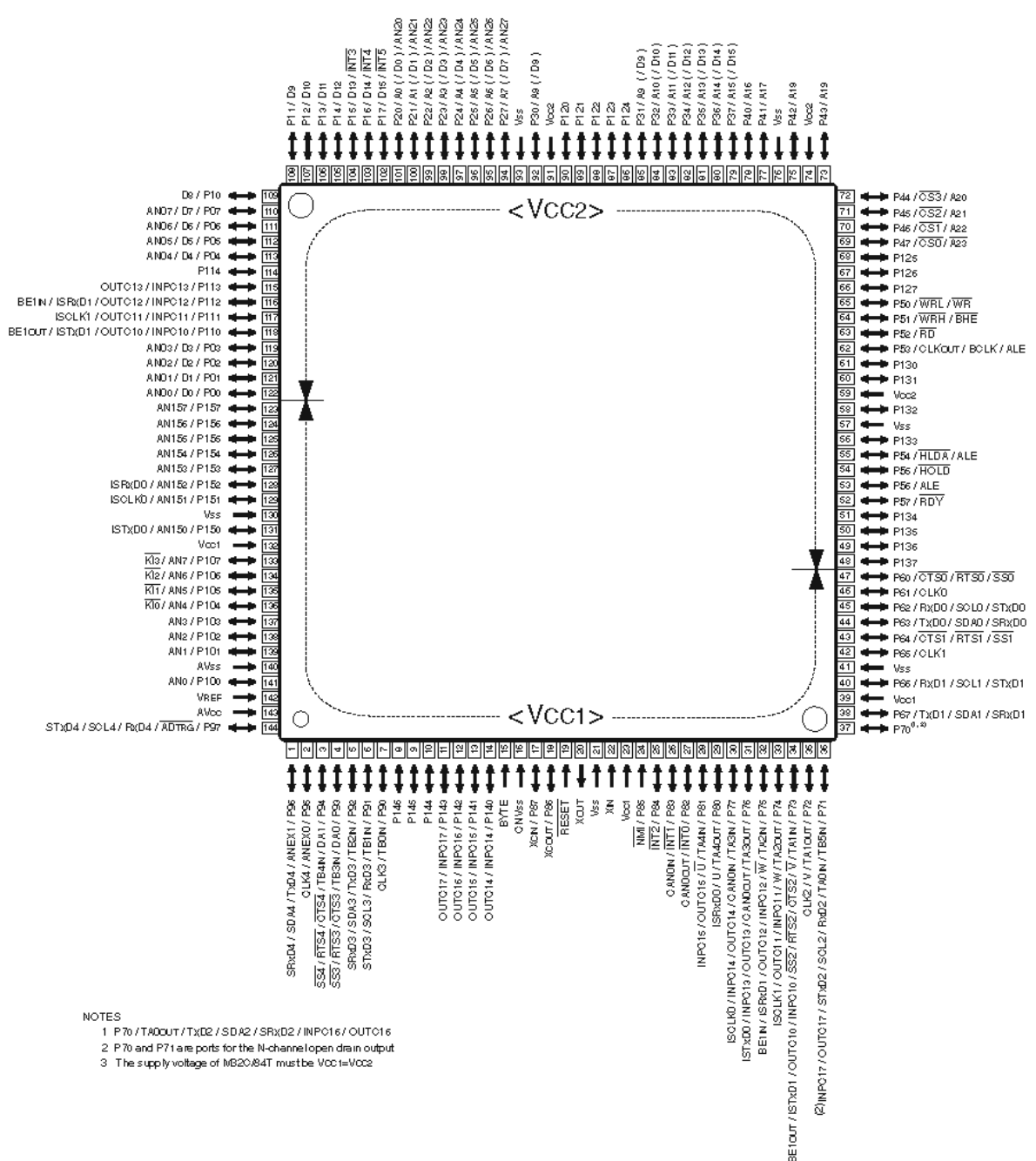

NOTES
 1. P7 to TAQOUT/TX02/SDA2/SRXD2/INP016/OUT016
 2. P7 and P71 are ports for the N-channel open drain output
 3. The supply voltage of M32C/84T must be Vcc1=Vcc2

IC301: M30845FJGP (FUNCTION P.C.B)
 16-bit Microprocessor

No.	Port Name	Terminal Name (P.C.B.)	I/O			Function
			PowerOn	Standby	MCUSleep [OFF]	
1	TXD4	TXDH (MtoV)	SO	0	0	Data transmits to VIDEO_CPU
2	CLK4	CLKH	SO	0	0	Clock transmits to VIDEO_CPU
3	DA1	LIMIT	DA	0	0	Limiter control output
4	DA0	FAN	DA	0	0	Temperature control FAN control output
5	SDA3/TXD3/TB2in	HDIMT	TMR	0	0	HDMI MUTE input
6	SCL3/RXD3/TB1in	/EN232C	I	0	0	VIDEO_CPU 232C communication line enable control
7	TB0in	HRES	TMR	0	0	VIDEO_CPU response return input
8	P146	/ICH	0	0	0	VIDEO_CPU reset
9	P145	HREQ	TMR	0	0	VIDEO_CPU I transmission demand input
10	P144	DMT	0	0	0	Digital FULL MUTE (HI=MUTE)
11	P143	/CSDAC3	0	0	0	
12	P142	/CSDAC2	0	0	0	* Chip enable for S, C, SW2chDAC (Reserve)
13	P141	/CSDAC1	0	0	0	2shDAC (PCM1791A) * Chip enable for 6
14	P140	/CSY	0	0	0	* Chip enable for YSS930 (#0 / #1 Common)
15	BYTE	BYTE	MCU	MCU	MCU	External data bus width change: 16 bit
16	CNVss	CNVss	MCU	MCU	MCU	Processor mode selection: Single chip mode/Hi: To boot mode with a built-in flash/At the time of hard reset: It is to boot mode at P50=H, P55=L, and CNVss=H
17	P87	/ICD	0	0	0	DIR initial clear
18	P86	/ICTI	0	0	0	TI initial clear
19	RESET	RESET	MCU	MCU	MCU	
20	Xout	Xout	MCU	MCU	MCU	
21	Vss	Vss	MCU	MCU	MCU	
22	Xin	Xin	MCU	MCU	MCU	
23	Vcc	Vcc	MCU	MCU	MCU	
24	NMI	NMI	IRQ	I	I	
25	INT2	REM1	IRQ	IRQ	IRQ	Remote control pulse input 1
26	INT1	REM2	IRQ	IRQ	IRQ	Remote control pulse input 2/Remote control pulse input for zone remote control
27	INT0	RXDR	IRQ	IRQ	IRQ	RS232C/YDC reception detection
28	TA4in	/VSYNC	TMR	0	0	Vertical sync pulse INT
29	P80	/CSTI	0	0	0	Chip enable for TI decoder DSP DA601
30	TA3in/P77	TIBUSY	I	0	0	TI BUSY detection/CDDA write-in DATA input
31	P76	SPIRDY	I / I	0 / 0	0 / 0	DA601 GP0(0): TI DA601 Serial Ready / DRI WCK output: DIR WCK input (WCK input for CDDA writing)
32	TA2in	/INTTI	TMR	0	0	TI (DA601) interruption
33	P74	/CSDIR	0	0	0	Chip enable for DIR
34	TA1in	/INTDIR	TMR	0	0	DIR interruption
35	P72/CLK2/TA1out	BT232C	I / I	I / I	0 / 0	RS232C flash write-in mode detection / MULTI CH INPUT key detection
36	P71/RxD2/SCO2	DRXM	SI	0	0	DABIC IC RxD (XM data reception) / 1.5k pull up to +5SPC
37	P70/TxD2/SDA2	DTXM	SO	0	0	DABIC IC TxD / 1.5k pull up to +5SPC
38	P67/TxD1	TXDR	SO / SO	SO / SO	0 / SO	RS232C: Usual RS-232C asynchronous communication data output / YDC: Transmitting terminal for AF220
39	Vcc	Vcc	MCU	MCU	MCU	
40	P66/RxD1	RXDR	SI / SI	SI / SI	SI [0] / SI	Usual RS-232C asynchronous communication data input / At the time of 232C driver OFF, since driver output is set to HiZ, it is LowFix processing / Transmitting terminal for AF220
41	Vss	Vss	MCU	MCU	MCU	
42	P65/CLK1	RTS / CLKF	SO / SO	SO / SO	0 / SO	Usual RS-232C asynchronous communication RTS output / Clock input for AF220
43	P64/CTS1/RTS1/	CTS/YDCBUSY	I / 0	I / 0	I [0] / 0	Usual RS-232C asynchronous communication CTS input / At the time of 232C driver OFF, since driver output is set to HiZ, it is LowFix processing / BUSY output for AF220
44	P63/TxD0	TXDD	SO	0	0	Serial data output to DIR, TI (DA601), YSS930, and DAC / DIR/ YSS: 4M, LSBF/TI: 1M, MSBF
45	P62/RxD0	RXDD	SI	0	0	Serial data reception to DIR, TI (DA601), YSS930, and DAC / DIR/YSS: 4M, LSBF/TI: 1M, MSBF
46	P61/CLK0	CLKD	SO	0	0	Serial Clock output to DIR, TI (DA601), YSS930, and DAC

RX-V1600/DSP-AX1600

IC301: M30845FJGP (FUNCTION P.C.B)
16-bit Microprocessor

No.	Port Name	Terminal Name	I/O			Function
			PowerOn	Standby	MCUSleep [AC OFF]	
47	P60		0	0	0	
48	P137	VRB	I	0	0	Volume Rotary B
49	P136	VRA	I	0	0	Volume Rotary A
50	P135	PGB	I	0	0	PROGRAM Rotary B
51	P134	PGA	I	0	0	PROGRAM Rotary A
52	P57/RDY	SCKA	0	0	0	Clock output for audio select IC
53	P56/RAS	SDTA	0	0	0	Data output for audio select IC / NJU: Transmitting dock 10us, MSB first
54	P55/HOLD	CEL	0	0	0	JRC analog SW IC CE1
55	P54/HLDA	CET	0	0	0	JRC analog SW IC CE2
56	P133	/HPMT	0	0	0 [0]	Headphone MUTE control
57	Vss	Vss	MCU	MCU	MCU	
58	P132	/FATT	0	0	0	FRONT attenuate output PL/PR MIXH
59	Vcc	Vcc	MCU	MCU	MCU	
60	P131	/MIC	I	0	0	MIC detection / 220k Pull Down
61	P130	/HP	I	0	0	Headphone detection / 100k Pull Up to +5SPC
62	P53/BCLK	CKEV	0	0	0	EVOL serial transmitting clock
63	P52/RD	DTEV	0	0	0	EVOL serial transmitting data / Clock speed 1M, MSB first
64	P51/WRH	/CEEV	0	0	0	EVOL CE
65	P50/WRL	XMPWR	0	0	0	XM Radio power supply control
66	P127	/FMFSW	0	0	0 [0]	Full Mute SWL/SWR/SW MONO
67	P126	/FMTC	0	0	0 [0]	Full Mute Center
68	P125	/FMFS	0	0	0 [0]	Full Mute SL/SR
69	P47/CS0	/FMFS	0	0	0 [0]	Full Mute FL/FR/SBL/SBR
70	P46/CS1	/ICFL	0	0	0	FL driver initial clear
71	P45/CS2	CEF2	0	0	0	FL enable 1
72	P44/CS3	CEF1	0	0	0	FL enable 2
73	P43/A19	ISB	I	0	0	Input selector Rotary B
74	Vcc	Vcc	MCU	MCU	MCU	
75	P42/A18	ISA	I	0	0	Input selector Rotary A
76	Vss	Vss	MCU	MCU	MCU	
77	P41/A17	PSWA	I	I	0	INT5: After [a SSW input] logic Key distinction
78	P40/A16	PSWB	I	I	0	INT5: After [a SSW input] logic Key distinction
79	P37/A15	SRYA	0	0	0	MAIN A SP RELAY
80	P36/A14	SRYB	0	0	0	MAIN B SP RELAY
81	P35/A13	SRYC	0	0	0	CENTER SP RELAY
82	P34/A12	SRYSB	0	0	0	SURROUND BACK SP RELAY
83	P33/A11	SRYSP	0	0	0	Presence/Zone SP RELAY
84	P32/A10	SRYSR	0	0	0	SURROUND/ZONE SP RELAY
85	P31/A9	FANLK	I	0	0	FAN lock detection / 100k Pull Up to +5M2
86	P124	PRY	0	0	0	Power relay control
87	P123	/ST	I	0	0	TUNER STEREO detection input / Pull Up to +5SPC
88	P122	TUNED	I	0	0	TUNER TUNED input / Pull Up +5SPC
89	P121	TUCE	0	0	0	PLL Chip select for TUNER
90	P120	/TMUTE	0	0	0	TUNER Mute output / Logic reversal according to Tr at a FUNCTION P.C.B.
91	Vcc		MCU	MCU	MCU	
92	P30/A8	PDLED	0	0	0	PureDirect LED
93	Vss		MCU	MCU	MCU	
94	AN27/P27/A7		0	0	0	
95	AN26/P26/A6		0	0	0	
96	AN25/P25/A5	/Z2MT	0	0	0 [0]	Zone2 MUTE control
97	AN24/P24/A4	/Z3MT	0	0	0 [0]	Zone3 MUTE control
98	AN23/P23/A3	/ICXM	0	0	0	DABIC IC reset (U model)
		-	0	0	0	(C, R, T, K, A, B, L, J models)
		RDSE	0	0	0	RDS Enable (G model)
99	AN22/P22/A2	RDATA2	0	0	0	Recout SW2 control (ROHM) data / Clock speed: 20us, MSBF
100	AN21/P21/A1	RLCK2	0	0	0	Recout SW2 control (ROHM) clock
101	AN20/P20/A0	PRI	I	0	0	Current protection detection / 100k Pull Down
102	P17/D15/INT5	PSW	IRQ	IRQ	IRQ	Main, Zone2, and 3 Power key interruption
103	P16/D14/INT4	SSW	IRQ	IRQ	IRQ	System power SW (Push lock SW)
104	P15/D13/INT3	PDET	IRQ	IRQ	IRQ	Power detect detection / At a SUPTR P.C.B., it is 100k Pull Up to 5M2

IC301: M30845FJGP (FUNCTION P.C.B)
 16-bit Microprocessor

No.	Port Name	Terminal Name	I/O			Function
			PowerOn	Standby	MCUSleep [AC OFF]	
105	P14/D12	SPC	O	O	O [O]	+5SPC Power supply ON/OFF control. (L=ON/H=OFF: Standby power requirement reduction sake) / Usually, Low fixes is standby power requirement reduction (MCUSleep) by making it HI, after the processing accompanying standby is completed. (An extended port and extended A/D do not operate at the time of HI.) / The time of AC IN and MCUSleep, please hold HighFix until there is a Power On input.
106	P13/D11	TRG1	O	O	O	DC TRIGGER output 1
107	P12/D10	TRG2	O	O	O	DC TRIGGER output 2
108	P11/D9		O	O	O	
109	P10/D8	VPOWER	O	O	O	VIDEO power supply control / At the time of Pure Direct is Low (VIDEO OFF)
110	P07/AN07/D7	VMT	O	O	O	Video output MUTE / Power ON/OFF / At the time PureDirect ON/OFF, this port is logic reversed in ON * Tr.
111	P06/AN06/D6	VBOOT	O	O	O	VIDEO_CPU boot enable
112	P05/AN05/D5	232PWR	O	O	O	232C driver ON/OFF control
113	P04/AN04/D4	BTSEL	O	O	O	VIDEO_CPU boot mode select
114	P114	RDATA	O	O	O	Recout SW1 control (ROHM) data / Clock speed: 20us, MSBF
115	P113	RLCK	O	O	O	Recout SW1 control (ROHM) clock
116	P112/ISRXD1	PLLR	I	O	O	PLL reception for TUNER / Reception clock 20us / LSB first
117	P111/ISCLK1	TUCK	O	O	O	PLL clock output for TUNER
118	P110/ISTXD1	TUDA	O	O	O	PLL data output for TUNER / Transmitting clock 4us / LSB first
119	P03/AN03/D3	CKZEV	O	O	O	EVOL serial transmitting clock for ZONE
120	P02/AN02/D2	DTZEV	O	O	O	EVOL serial transmitting data for ZONE / Clock speed: 1M, MSB first
121	P01/AN01/D1	/ICZEV	O	O	O	EVOL1 Reset for ZONE
122	P00/AN00/D0	/CEZEV1	O	O	O	EVOL1 CE for ZONE
123	AN157/P157	/CEZEV2	O	O	O	EVOL2 CE for ZONE
124	AN156/P156	REC	AD	O	O	AD REC OUT SEL taking in
125	AN155/P155	KEY0	AD	O	I [O]	Key0 AD value taking in
126	AN154/P154	KEY1	AD	O	I [O]	Key1 AD value taking in
127	AN153/P153	/OSDCE	O	O	O	OSD CE
128	AN152/P152/ISRXD0	RDS	I	O	O	RDS Rx D
129	AN151/P151/ISCLK0	SCKN	O	O	O	NONE AUDIO clock output (FL/RDS/OSD) / FL: 2us clock, MSBF RDS: 20us clock, LSBF
130	Vss	Vss	MCU	MCU	MCU	
131	AN150/P150/ISTXD0	SDTN	O	O	O	NONE AUDIO data output (FL/RDS/OSD)
132	Vcc	Vcc	MCU	MCU	MCU	
133	P107/AN7	DEST	AD	O	I [O]	Model distinction is based on AD value. / Waiting for after [AD input port setup] 1msec is carried out at the time of AD taking in at the time of Power On.
134	P106/AN6	MODEL	AD	O	I [O]	Model distinction is based on AD value. / Waiting for after [AD input port setup] 1msec is carried out at the time of AD taking in at the time of Power On.
135	P105/AN5	THM1	AD	O	I [O]	AD temperature detection detection 1
136	P104/AN4	THM2	AD	O	I [O]	AD temperature detection detection 2
137	P103/AN3	PRD	AD	O	O	Power amplifier DC protection detection
138	P102/AN2	PRV	AD	O	O	Power supply protection detection 1
139	P101/AN1	PRVS	AD	O	O	Power supply protection detection 2 (Power supply turned off by Pure Direct)
140	Avss	AVSS	MCU	MCU	MCU	
141	P100/AN0	PLMT	AD	O	O	AD Power Limiter detection
142	Vref	VREF	MCU	MCU	MCU	
143	Avcc	AVCC	MCU	MCU	MCU	
144	RXD4	RXDH	SI	O	O	Data reception from VIDEO_CPU

Key Input (A-D) Pull-Up Resistance 10 k-ohms

Ohm	0	+1.2k	+1.2k	+1.8k	+2.7k	+3.3k	+4.7k	+8.2k
V	~ 0.26	~ 0.75	~ 1.22	~ 1.76	~ 2.28	~ 2.75	~ 3.24	~ 3.75
KEY0	TONE CONTROL	STRAIGHT EFFECT	TUNING MODE	MEMORY	FM/AM	PRESET/TUNING EDIT	PRESET/TUNING >	PRESET/TUNING <
KEY1	ZONE CONTROL	A/B/C/D/E	AUDIO SELECT	SPEAKERS A	SPEAKERS B	PURE DIRECT	-	-

RX-V1600/DSP-AX1600

IC501: M30805SGP (D-VIDEO P.C.B)
16-bit Microprocessor

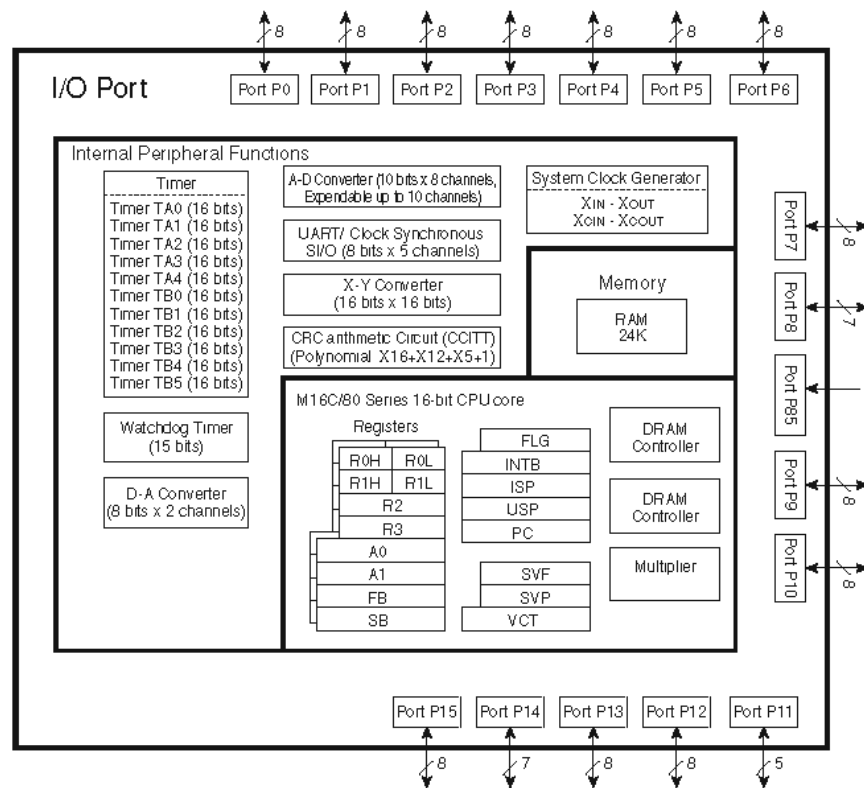
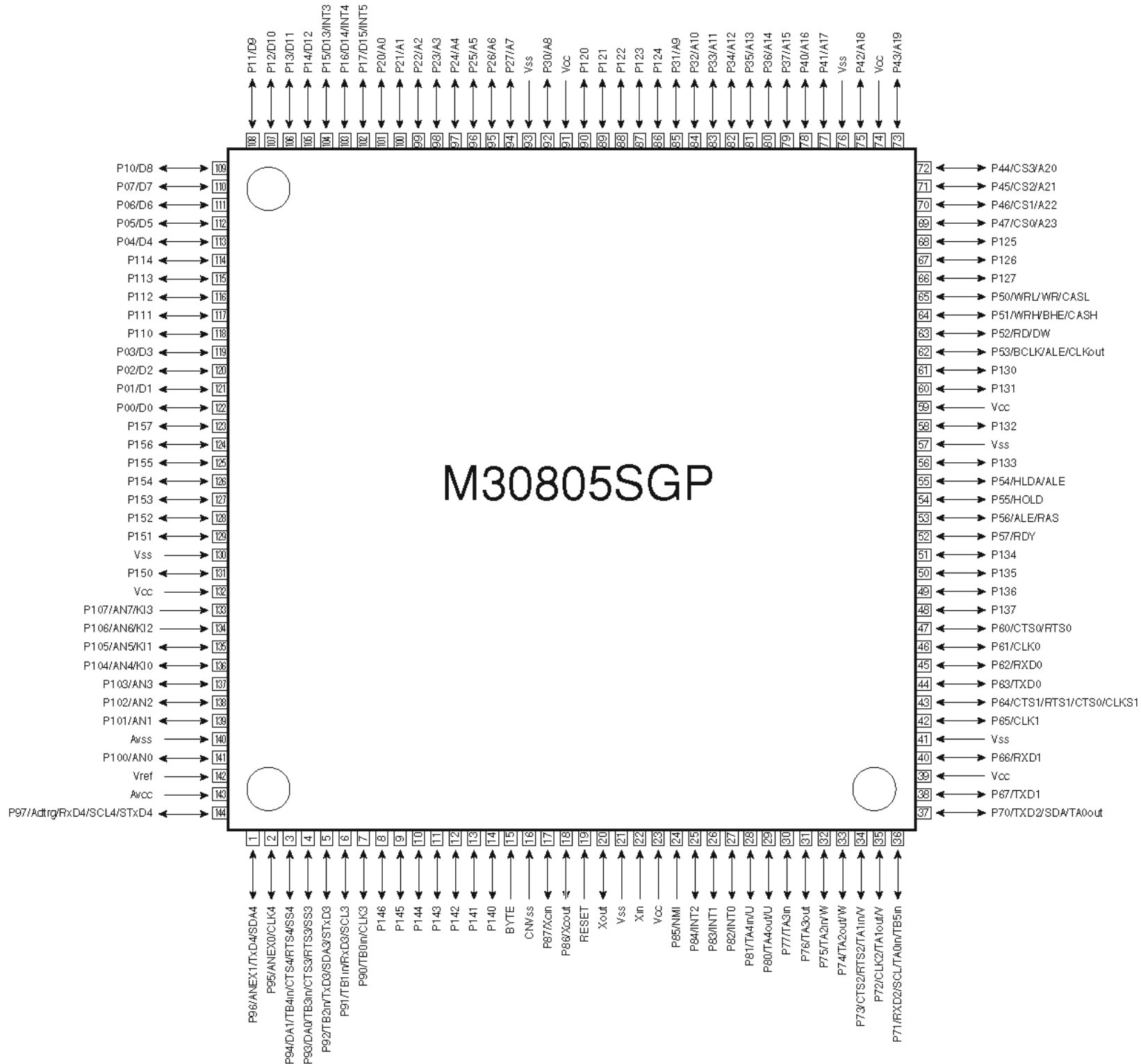

IC501: M30805SGP (D-VIDEO P.C.B)
 16-bit Microprocessor

No.	Port Name	Terminal Name (P.C.B.)	I/O [OFF]	Function
1	P96/SDA4	SDAL	SIO	I2C SDA Input/Output signal (for 100kHz device)
2	P95/CLK4		O	
3	P94/TB4in	DACSEL	DA	DAC fs Select
4	P93/TB3in		O	
5	P92/SDA3	SDAH	SIO	I2C SDA Input/Output signal (for HDMI device)
6	P91/SCL3	SCLH	SO	I2C SCL Output signal (for HDMI device)
7	P90/TB0in		O	
8	P146		O	Terminal for monitors for development
9	P145		O	Terminal for monitors for development
10	P144		O	Terminal for monitors for development
11	P143		O	Terminal for monitors for production inspection
12	P142		O	Terminal for monitors for production inspection
13	P141		O	Terminal for monitors for production inspection
14	P140		O	Terminal for monitors for production inspection
15	BYTE		MCU	Data bus width setup: Set as 16bit=Low
16	CNVSS		MCU	Processor mode: Set as Hi
17	P87		O	
18	P86	BOOT (/EN232)	I [O]	YDC boot signal input/232C line opening demand (Video -> Main)
19	/RESET	/RES	MCU	Reset signal input
20	XOUT		MCU	Ceramic vibrator 10MHz
21	Vss		MCU	GND
22	XIN		MCU	Ceramic vibrator 10MHz
23	Vcc		MCU	3.3V
24	P85/NMI		I	No used
25	P84/INT2	/REM	IRQ	For development
26	P83/INT1	/INTAD	IRQ	Interruption signal from ADV7401
27	P82/INT0	/INTH	IRQ	HDMI Tx/Rx interruption
28	P81/TA4in	VS	I	HDMI VSYNC input (Reserve for frequency distinction)
29	P80/TA4out		O	
30	P77/TA3in		[I]	Starting option
31	P76/TA3out		[I]	Starting option
32	P75/TA2in	HDMINT	O	HDMI interruption demand
33	P74/TA2out	232PWR	I	232C transceiver notice input of a shutdown
34	P73/TA1in		O	
35	P72/CLK2		O	
36	P71/SCL2	SCLV	SI	I2C SCL output signal (for Video devices)
37	P70/SDA2	SDAV	SO	I2C SDA Input/Output signal (for Video devices)
38	P67/TxD1	TXD1	SO	Serial I/F for writing YDC / Serial I/F for writing debug
39	Vcc		MCU	3.3V
40	P66/RxD1	RXD1	SI	Serial I/F for writing YDC / Serial I/F for writing debug
41	Vss		MCU	GND
42	P65/CLK1	RTS1	O	Serial I/F for writing YDC/232C
43	P64/CTS1	CTS1	I	Serial I/F for writing YDC/232C
44	P63/TxD0	VtoM	SO	MAIN microcomputer I/F SPI
45	P62/RxD0	MtoV	SI	MAIN microcomputer I/F SPI
46	P61/CLK0	MCLK	SI	MAIN microcomputer I/F SPI
47	P60/CTS0/RTS0	MRES	O	MAIN microcomputer I/F RES output signal
48	P137	MREQ	O	MAIN microcomputer I/F REQ output signal
49	P136		O	
50	P135	SPIRDY	I	Word clock input for writing CDDA
51	P134	SPIDAT	I	Data input for writing CDDA
52	P57/RDY	/RDY	I	YGV/WAIT signal input
53	P56/ALE/RAS		O	No used
54	P55/HOLD		I	No used
55	P54/HLDA/ALE		O	No used
56	P133	PSENB	O	HDMI Power Signal Enable
57	Vss		MCU	GND
58	P132	DDCENB	O	HDMI DDC Enable control
59	Vcc		MCU	3.3V

RX-V1600/DSP-AX1600

IC501: M30805SGP (D-VIDEO P.C.B)
16-bit Microprocessor

No.	Port Name	Terminal Name (P.C.B.)	I/O [OFF]	Function
60	P131	HPD1ENB	O	HDMI HPD1 Enable control
61	P130	HPD0ENB	O	HDMI HPD0 Enable control
62	P53/BCLK		O	No used
63	P52/RD/DW	/RD	BUS	BUS I/F
64	P51/WRH/BHE		BUS	BUS I/F
65	P50/WRL/WR	/WR	BUS	BUS I/F
66	P127		O	
67	P126		O	
68	P125		O	
69	P47/CS0/A23		BUS	
70	P46/CS1/A22		BUS	
71	P45/CS2/A21		BUS	FLASH A20/NC2, YGV A21
72	P44/CS3/A20		BUS	FLASH A19/NC1, YGV A20
73	P43/A19		BUS	FLASH A18, YGV A19
74	Vcc		MCU	3.3V
75	P42/A18		BUS	FLASH A17, YGV A18
76	Vss		MCU	GND
77	P41/A17		BUS	FLASH A16, YGV A17
78	P40/A16		BUS	FLASH A15, YGV A16
79	P37/A15		BUS	FLASH A14, YGV A15
80	P36/A14		BUS	FLASH A13, YGV A14
81	P35/A13		BUS	FLASH A12, YGV A13
82	P34/A12		BUS	FLASH A11, YGV A12
83	P33/A11		BUS	FLASH A10, YGV A11
84	P32/A10		BUS	FLASH A9, YGV A10
85	P31/A9		BUS	FLASH A8, YGV A9
86	P124	YGVDET	I	Pull down: No YGV
87	P123	VTEST1	O	Self inspection result is outputted for production inspection (Video)
88	P122	VTEST2	O	Self inspection result is outputted for production inspection (Video)
89	P121	VTEST3	O	Self inspection result is outputted for development (Video)
90	P120	VTEST4	O	Self inspection result is outputted for development (Video)
91	Vcc		MCU	3.3V
92	P30/A8		BUS	FLASH A7, YGV A8
93	Vss		MCU	GND
94	P27/A7		BUS	FLASH A6, YGV A7
95	P26/A6		BUS	FLASH A5, YGV A6
96	P25/A5		BUS	FLASH A4, YGV A5
97	P24/A4		BUS	FLASH A3, YGV A4
98	P23/A3		BUS	FLASH A2, YGV A4
99	P22/A2		BUS	FLASH A1, YGV A2
100	P21/A1		BUS	FLASH A0, YGV A1
101	P20/A0		BUS	No used
102	P17/D15/INT5	D15	BUS	Data bus
103	P16/D14/INT4	D14	BUS	Data bus
104	P15/D13/INT3	D13	BUS	Data bus
105	P14/D12	D12	BUS	Data bus
106	P13/D11	D11	BUS	Data bus
107	P12/D10	D10	BUS	Data bus
108	P11/D9	D9	BUS	Data bus
109	P10/D8	D8	BUS	Data bus
110	P07/D7	D7	BUS	Data bus
111	P06/D6	D6	BUS	Data bus
112	P05/D5	D5	BUS	Data bus
113	P04/D4	D4	BUS	Data bus
114	P114	/ICP	O	IC signal to PD0280B. Cancels after Clock supply.
115	P113	/AUPH	O	Video course (Decoder output) to HDMI ON/OFF
116	P112		O	
117	P111	/ICY	O	IC signal to YGV619
118	P110	/ICV	O	IC signal to Video system device

IC501: M30805SGP (D-VIDEO P.C.B)
16-bit Microprocessor

No.	Port Name	Terminal Name (P.C.B.)	I/O [OFF]	Function
119	P03/D3	D3	BUS	Data Bus
120	P02/D2	D2	BUS	Data Bus
121	P01/D1	D1	BUS	Data Bus
122	P00/D0	D0	BUS	Data Bus
123	P157	/AUPS	O	Video course (Scaler output) to HDMI ON/OFF
124	P156	/AUPP	O	Video course (MS1A output) to HDMI ON/OFF
125	P155	/AUPI	O	Video course (480i output) to HDMI ON/OFF
126	P154	/OSDCEV	O	Chip enable output to OSD
127	P153	BDEN	O	Enable for BD7851 control
128	P152	BDLT	O	Latch for BD7851 control
129	P151	SDTV	O	Data for BD7851 control
130	Vss		MCU	GND
131	P150	SCKV	O	Clock for BD7851 control
132	Vcc		MCU	3.3V
133	P107/AN7	/MTMON	O	MUTE to the monitor out from a Video microcomputer
134	P106/AN6	/MTZ2	O	MUTE to the ZONE2 out from a Video microcomputer
135	P105/AN5	Reserve	O	
136	P104/AN4	SVDET	I	S input detection
137	P103/AN3	VBOOT	I	Enable to boot mode
138	P102/AN2	BTSEL	I	Boot mode select
139	P101/AN1	Reserve	I	
140	Avss		MCU	GND
141	P100/AN0		O	
142	Vref		MCU	3.3V
143	Avcc		MCU	3.3V
144	P97/SCL4	SCLL	SO	I2C SCL output signal (for 100kHz device)

MEMO

A large rectangular area with a double-line border, intended for writing a memo. The area is currently blank.

■ BLOCK DIAGRAM (1/3)

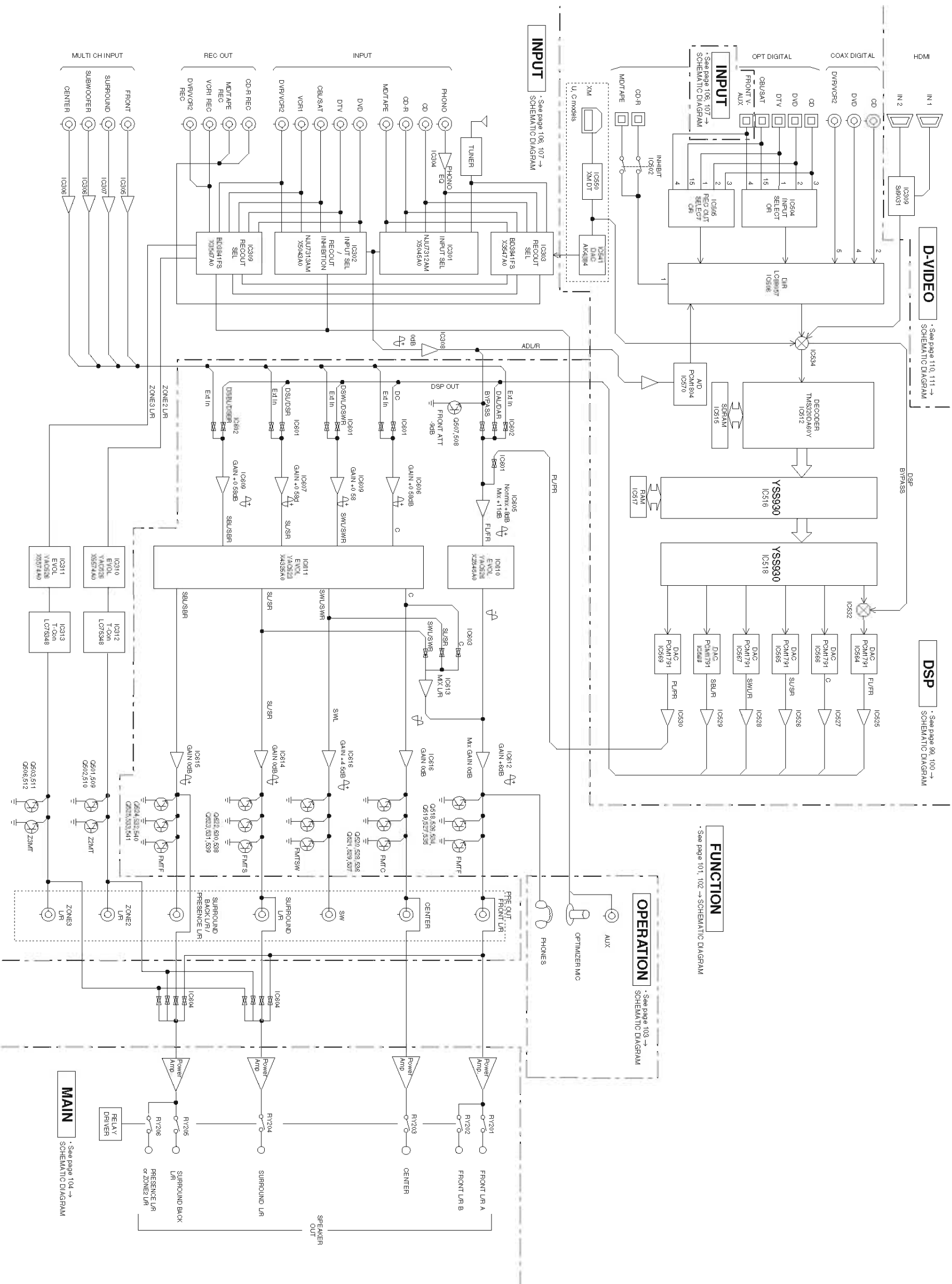

1 2 3 4 5 6 7

A B C D E F G H I J

■ BLOCK DIAGRAM (2/3)

Composites-Video

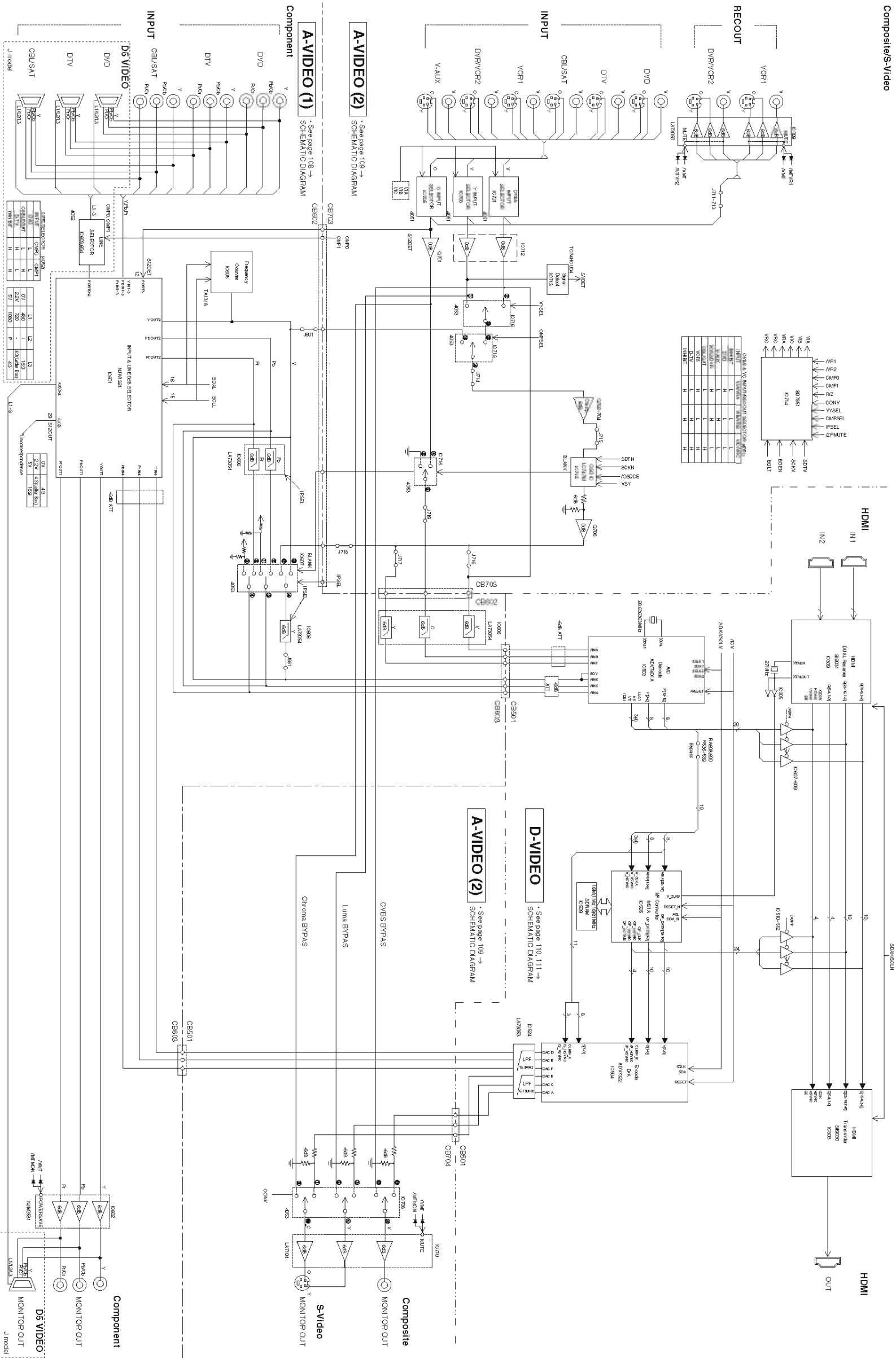

1 ■ BLOCK DIAGRAM (3/3)

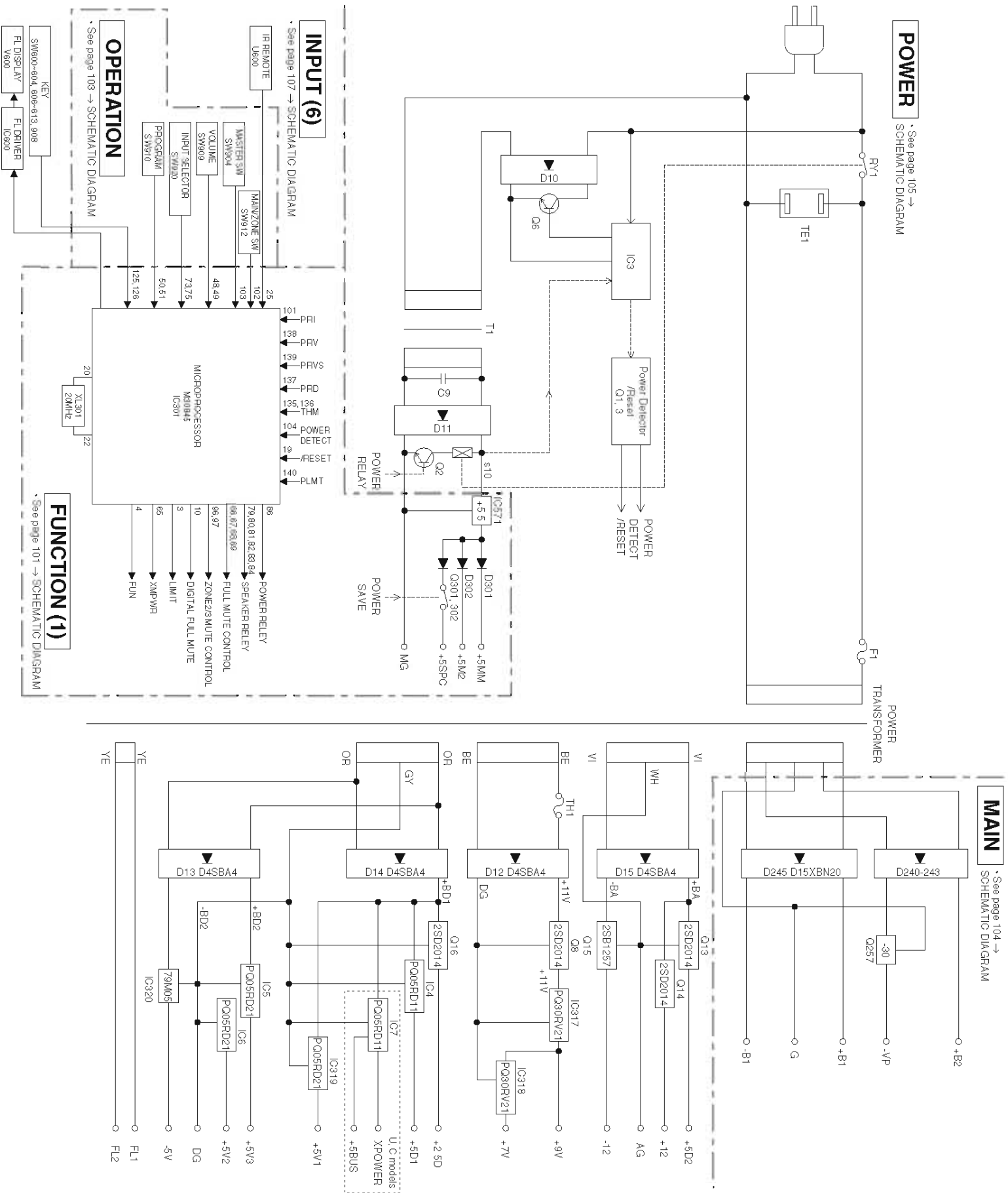

PIN CONNECTION DIAGRAM

• ICS

LM61CIZ 	NUM2391DL1-25 NUM2845DL1-33 NUM2885DL1-18 NUM2885DL1-33		NUM79M05FA 	PQ012FZ01ZPH PQ025EZ5MZP		PQ05RD11
PQ05RD21 PQ30RV21 	μPC2905AT-E1-AZ 	μPC29M33TE-E1-AZ 	μPC37M31TU-E1-AZ 	24LC04BTJ/SN NES532DR 		
BA15218F 	LE50ABD NUM2068MD-TE2 PCA9540BDP 	PST9242NR SN74AHC1G08DCKR SN74AHC1G125DCKR SN74AHC1G32DCKR SN74LVCG1G125DCKR SN74LVCG17DCKR 	RHSRE58AA-T1-FA 	ADM222ARZ 		
SN74AHC2GU04HDCR SN74CBT3306PWR TK15420M μPC4570G2 SN74LVCG2G125DCUR 	NUM2581M SN74AHC108PWR SN74AHC100PWR SN74LVU04APWR SN74LV08APWR SN74LV157APWR 	AK4384ET CD4051BNSR LA7104M MM74HC4051S1X MM74HC4052S1X MM74HC4053S1X SN74LS151NSR TC74VHC153FT 				
TC4013BP TC74HCU04AFEL 	SN74AHC125PWR SN74LV245APWR SN74LV245APWR SN74LV245APWR SN74LV245APWR 	PCM1804DBR 	LC75348M NJU7311AM NJU7312AM NJU7313AM TA1318AF 			
BD3841FS 	LA73050-TLM-E LA73053-TLM-E LA73054-TLM-E 	BD7851FP-E2 	MSM514260E-60US 			
MX29LV400BTC-70G 	F2802E-01 YAC523-EVR2 	NJW1321FP1 				

LC89057W-VF4A-E 	MX29LV320ABTC-90 	W9816G6CH-7 	ADV7322KSTZ M66003-0131FP
---------------------	----------------------	-----------------	----------------------------------



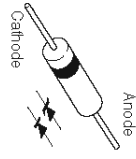
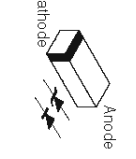
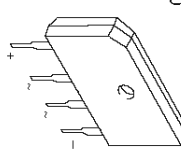
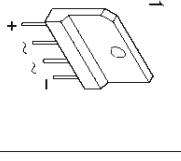
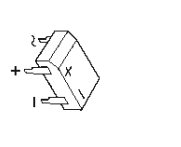

SI19030 	ADV7401BSTZ-80 YSS930 	M3080SSGP M30845FJGP MATISSE SI19031
-------------	------------------------------	---

D60YA003BPYP225

• Diodes

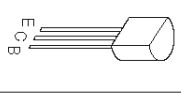
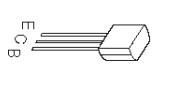
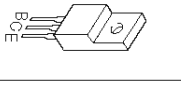
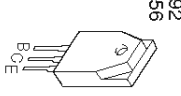
<p>1N4002S 1SS133 1SS244 MTZJ10B MTZJ13A MTZJ33B MTZJ47C MTZJ51B MTZJ51C MTZJ68B MTZJ7.5C</p> 	<p>1SS355 1SS380 MA8043-L MA8051-L MA8051-M MA8062-M MA8068-L MA8100-L MA8130-M RB50V-40 RB501V-40</p> 	<p>D2SBA20</p> 	<p>D15XB20 D4SBS4-4101</p> 	<p>S1NB20 S1NB80</p> 
---	--	--	--	--

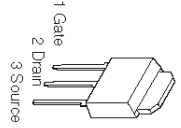
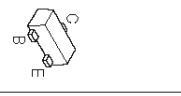
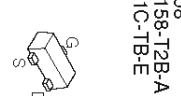
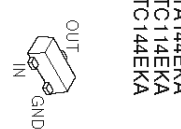
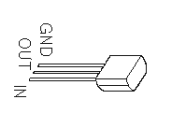
• Transistors

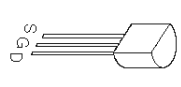
<p>2SA1015 2SA949 2SA970 2SC1815 2SC2229 2SC2240 2SC2878</p> 	<p>2SD1915F</p> 	<p>2SA1837 2SB1257 2SB1274 2SB941 2SC3852 2SC4793 2SD2014</p> 	<p>A2151/C6011 2SA1492 2SC3856</p> 	<p>μPA672T-T1-A</p> <p>1 Source 1 (S1) 2 Drain 1 (D1) 3 Drain 2 (D2) 4 Source 2 (S2) 5 Gate 2 (G2) 6 Drain 1 (D1)</p> 	<p>2SK3850</p> <p>4 Drain 1 Gate 2 Drain 3 Source</p> 	<p>2SA1036KT146 2SA1037K 2SC2412K 2SC3326 2SC3878K 2SC3906K 2SC4081 2SD1938F</p> 	<p>2N7002-NL 2SK208 2SK2158-T2B-A 5HP01C-TB-E</p> 	<p>DTA114EKA DTA144EKA DTC114EKA DTC144EKA</p> 	<p>DTC144ESA-TP</p> 	<p>2SA1708 2SC4488</p> 	<p>2SK246</p> 
---	--	--	---	---	--	--	---	--	---	---	---

PRINTED CIRCUIT BOARD

DSP (1) P.C.B. (Side A) Lead Free Solder Used

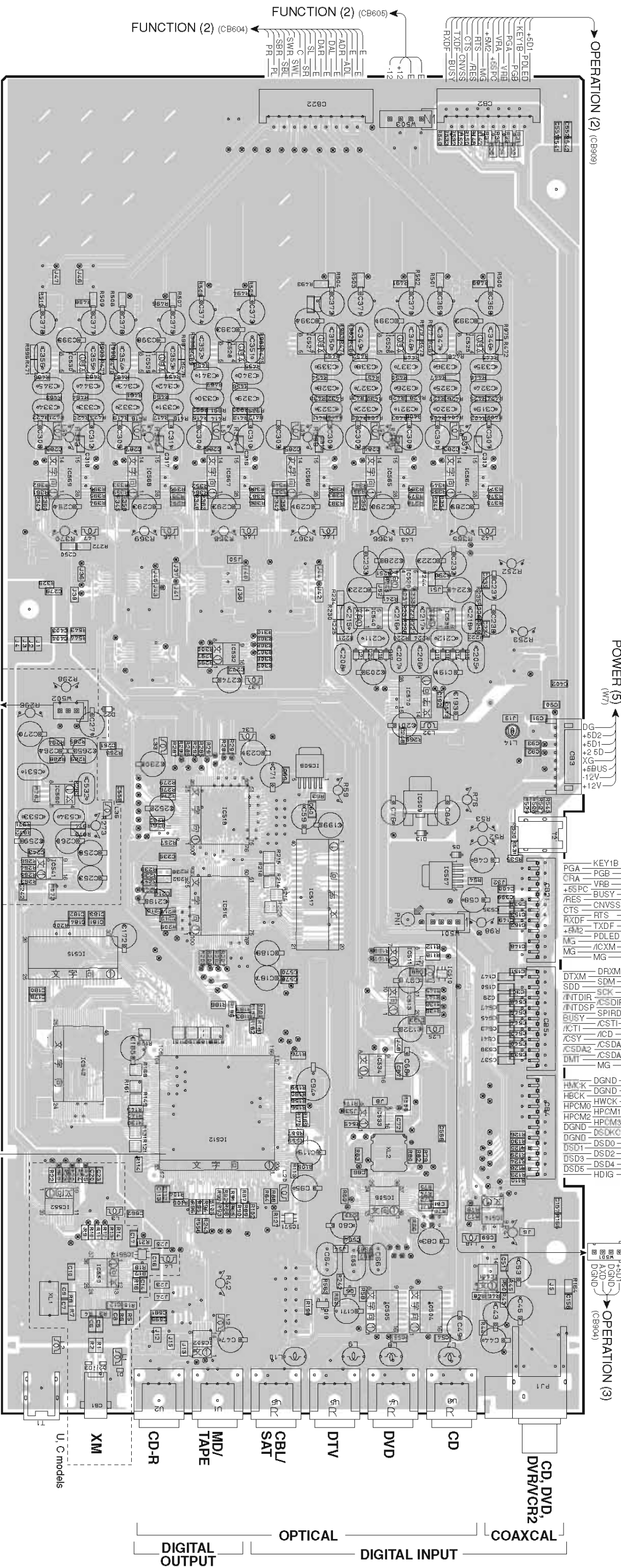

INPUT (1) (CB907)

No replacement part available / ユーザー部品供給なし

Circuit No.	U, C	R, T, K, A, B, G, L, J
R549, 550	X	O

X : NOT USED
O : USED/APPLICABLE

Semiconductor Location

Ref.no.	Location	Ref.no.	Location	Ref.no.	Location	Ref.no.	Location	Ref.no.	Location	Ref.no.	Location
D1	I5	D20	E3	IC510	G3	IC526	C3	IC542	G5	IC570	E3
D2	I5	D21	E3	IC511	G3	IC527	C4	IC550	I5	IC571	H4
D3	I5	D22	E5	IC512	H4	IC528	C4	IC551	I5	Q6	I4
D5	F3	IC501	I3	IC513	G3	IC529	C5	IC552	H5	Q19	I4
D13	F3	IC502	I4	IC514	H3	IC530	C5	IC560	F5		
D14	E3	IC504	I3	IC515	G5	IC532	E4	IC564	D3		
D15	E3	IC505	I3	IC516	G4	IC533	H3	IC565	D3		
D16	E3	IC506	H3	IC517	F4	IC534	H3	IC566	D4		
D17	E3	IC507	F3	IC518	F4	IC539	E3	IC567	D4		
D18	E3	IC508	F4	IC520	D3	IC540	E3	IC568	D5		
D19	E3	IC509	F3	IC525	C3	IC541	F5	IC569	D5		

1 ■ PRINTED CIRCUIT BOARD

DSP (1) P.C.B. (Side B) Lead Free Solder Used

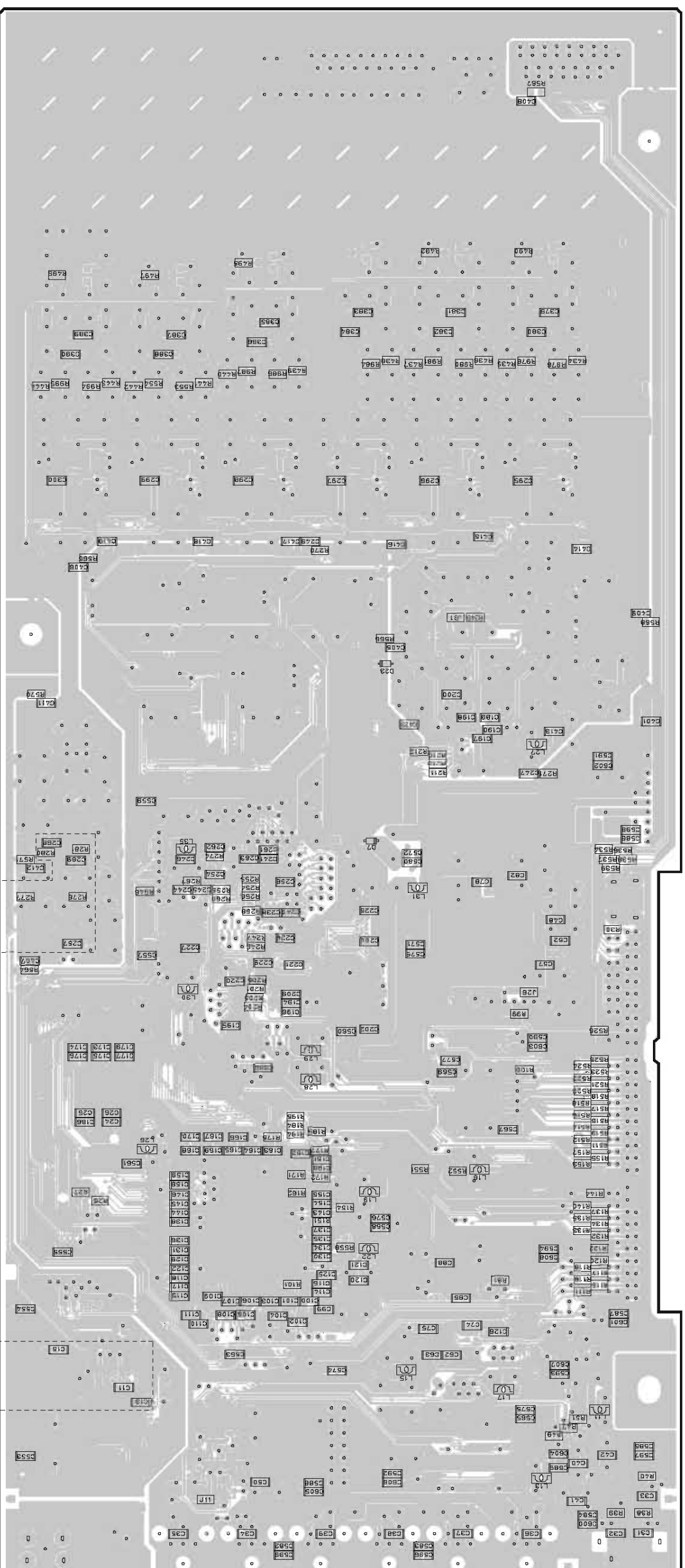

• Semiconductor Location

Ref.no.	Location
D7	F3
D23	E3

Circuit No.

R551, 552

X : NOT USED
O : USED/APPLICABLE

Circuit No.	U.C	R.T.K.A.B.G.L.J
R551, 552	X	O

PRINTED CIRCUIT BOARD

FUNCTION (1) P.C.B. (Side A) Lead Free Solder Used

Circuit No.	U.C.R.T.K.A.L	B.G	J	Destination
R369	O	O	X	

X : NOT USED
O : USED/APPLICABLE

• Semiconductor Location

Ref.no.	Location	Ref.no.	Location
D301	H4	Q308	D5
D302	H4	Q309	D5
D309	D5	Q310	D3
D310	D5	Q311	D3
D312	F5	Q312	E3
D313	F5	Q313	D3
D314	F6	Q314	E3
IC301	E4	Q315	E3
IC571	H4	Q324	H6
Q301	G4	Q326	F5
Q302	G4	Q327	F5
Q303	D4	Q328	F6
Q307	D5		

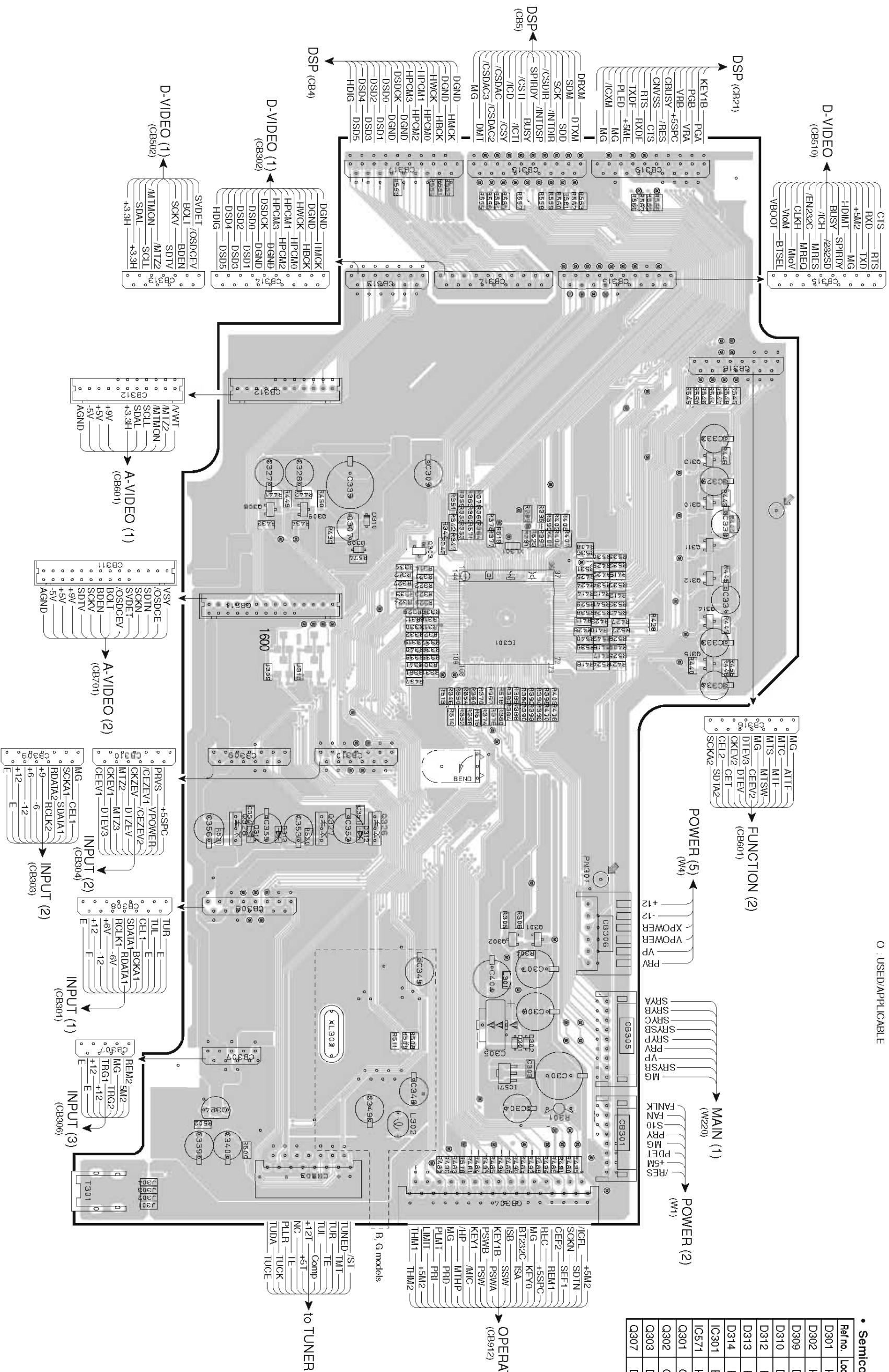

1 ■ PRINTED CIRCUIT BOARD

FUNCTION (1) P.C.B. (Side B) Lead Free Solder Used

• Semiconductor Location

Ref no.	Location
D303	E5
D304	E5
D305	E5
D306	E4
D307	E4
D308	F4
D311	H6
IC302	H5
Q304	D5
Q305	D4
Q306	D4
Q323	H5
Q325	G5

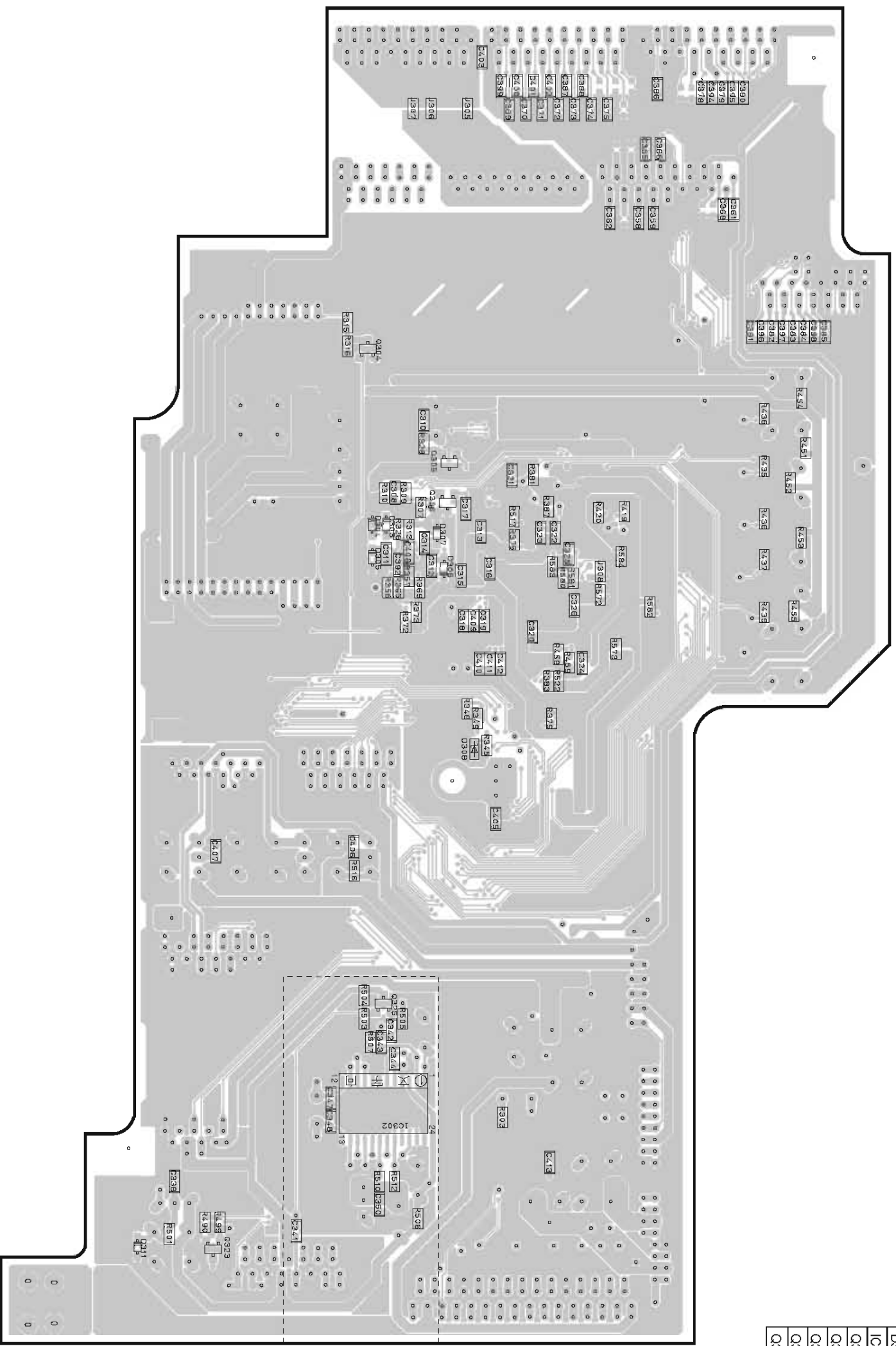

B, G models

PRINTED CIRCUIT BOARD

FUNCTION(2) P.C.B. (Side A) Lead Free Solder Used

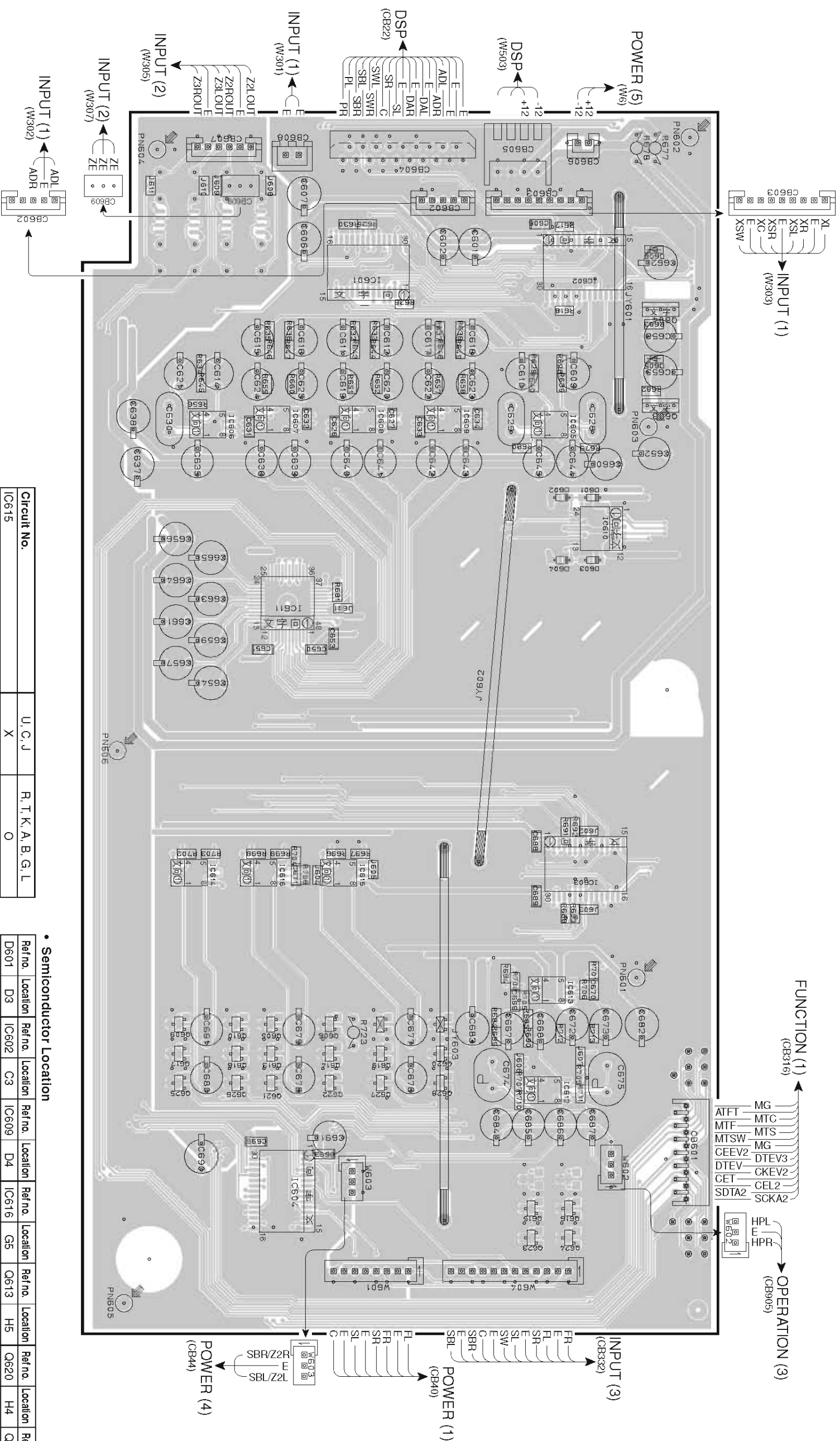

Circuit No.	U, C, J	R, T, K, A, B, G, L
IC615	X	O
J604, 605	O	X

X : NOT USED
O : USED/APPLICABLE

Semiconductor Location

Ref.no.	Location	Ref.no.	Location	Ref.no.	Location	Ref.no.	Location	Ref.no.	Location	Ref.no.	Location
D601	D3	IC602	C3	IC609	D4	IC616	G5	Q613	H5	Q620	H4
D602	D3	IC603	F3	IC610	D3	Q603	D3	Q614	H5	Q621	H5
D603	E3	IC604	H5	IC611	E5	Q604	C3	Q615	I3	Q622	H5
D604	E3	IC605	D3	IC612	H3	Q605	G5	Q616	I3	Q623	I3
D605	C3	IC606	D5	IC613	G3	Q606	G5	Q617	H6	Q624	I3
D606	C3	IC607	D5	IC614	G5	Q609	G6	Q618	H5	Q625	H6
IC601	C4	IC608	D4	IC615	G4	Q610	G5	Q619	H4	Q626	H5

A B C D E F G H I J

1 ■ PRINTED CIRCUIT BOARD

FUNCTION (2) P.C.B. (Side B) Lead Free Solder Used

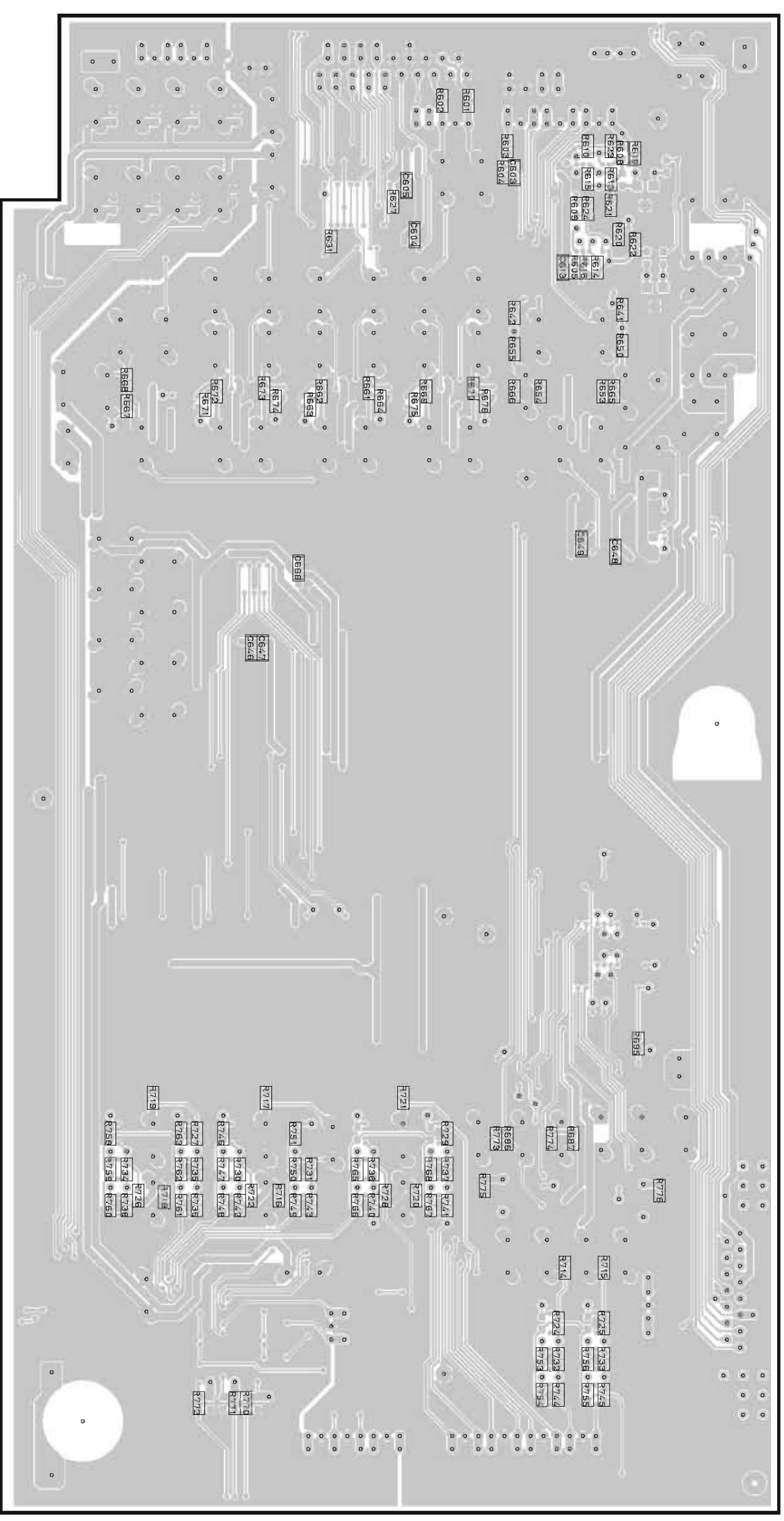

7

6

5

4

3

2

1

■ PRINTED CIRCUIT BOARD

OPERATION (1) P.C.B.
(Side A)

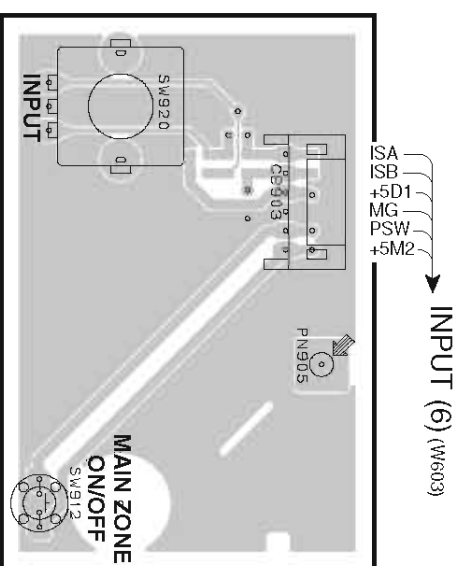

OPERATION (1) P.C.B.
(Side B) Lead Free Solder Used

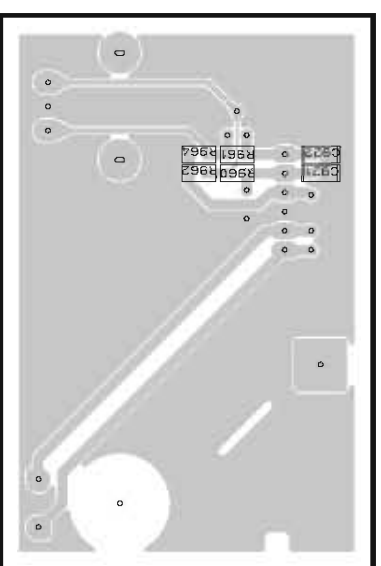

OPERATION (5) P.C.B.
(Side A)

OPERATION (2) P.C.B.
(Side A)

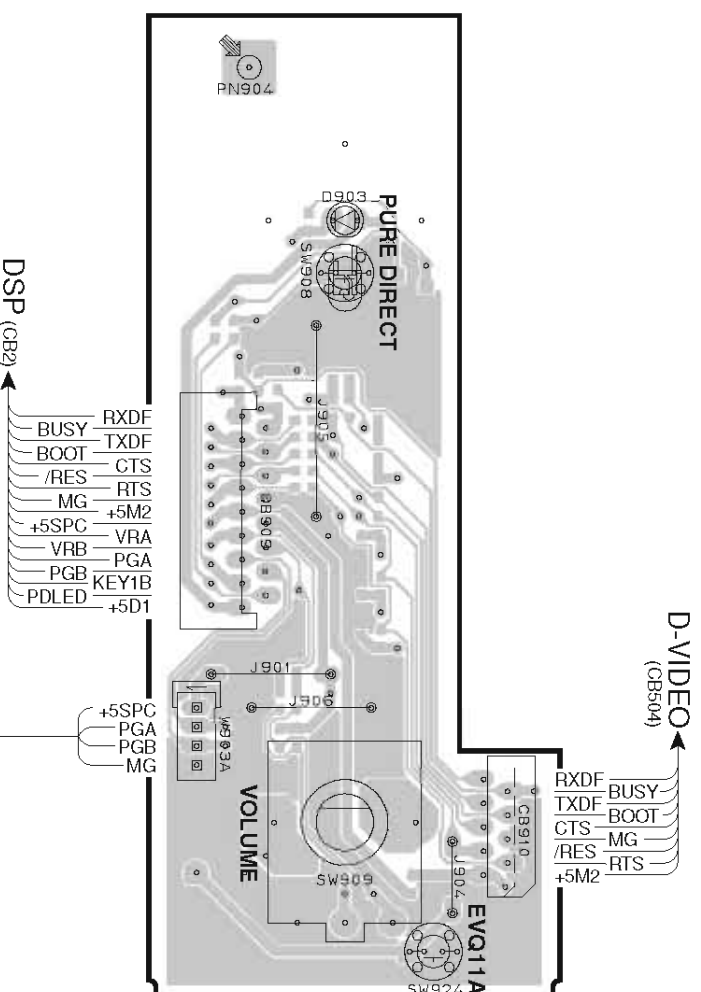

OPERATION (4) P.C.B.
(Side A)

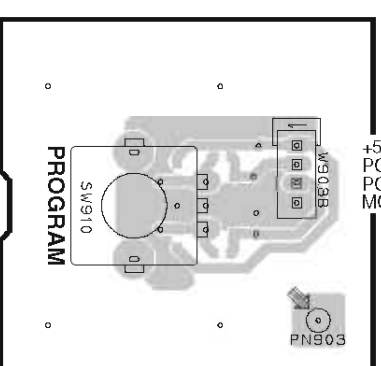

OPERATION (2) P.C.B.
(Side B) Lead Free Solder Used

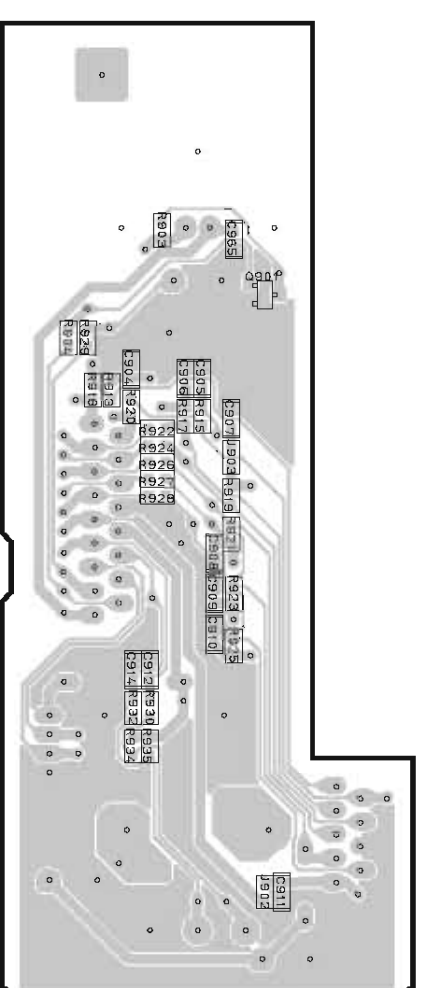

OPERATION (4) P.C.B.
(Side B) Lead Free Solder Used

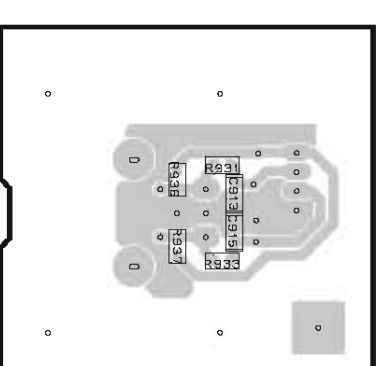

• Semiconductor Location

Ref. no.	Location
D903	D3
Q901	H3

1 ■ PRINTED CIRCUIT BOARD

OPERATION (3) P.C.B.
(Side A)

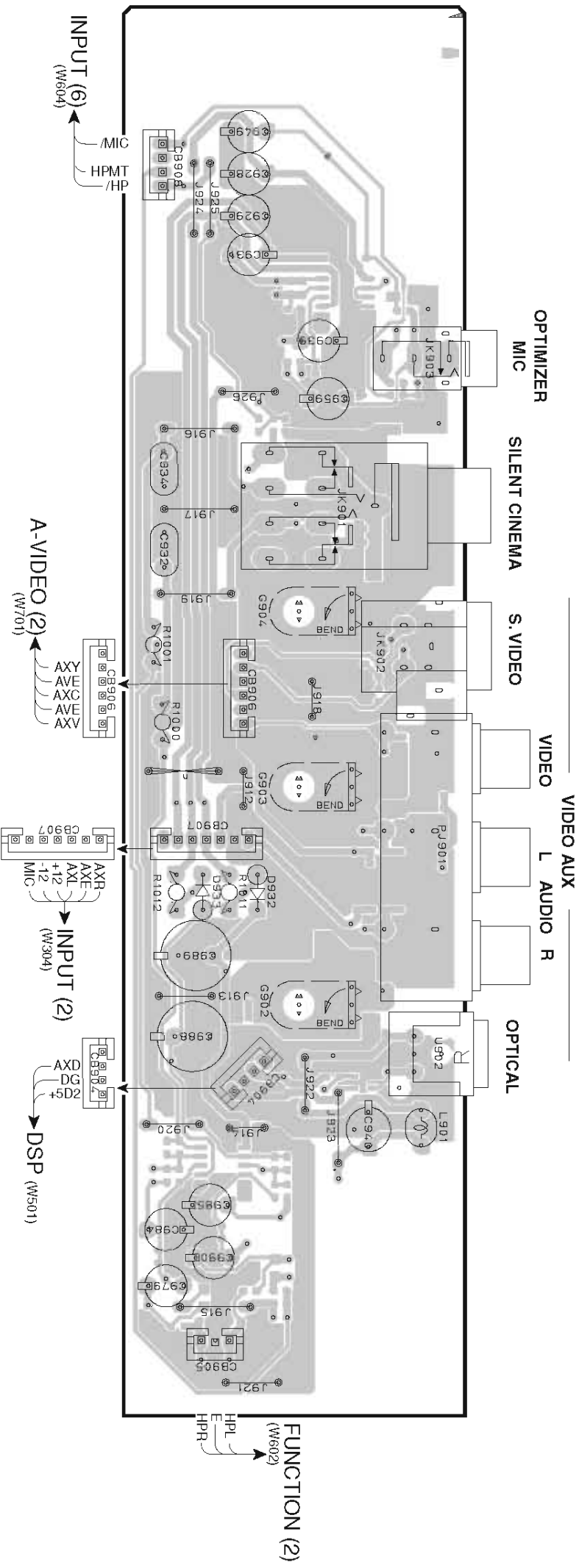

OPERATION (3) P.C.B.
(Side B) Lead Free Solder Used

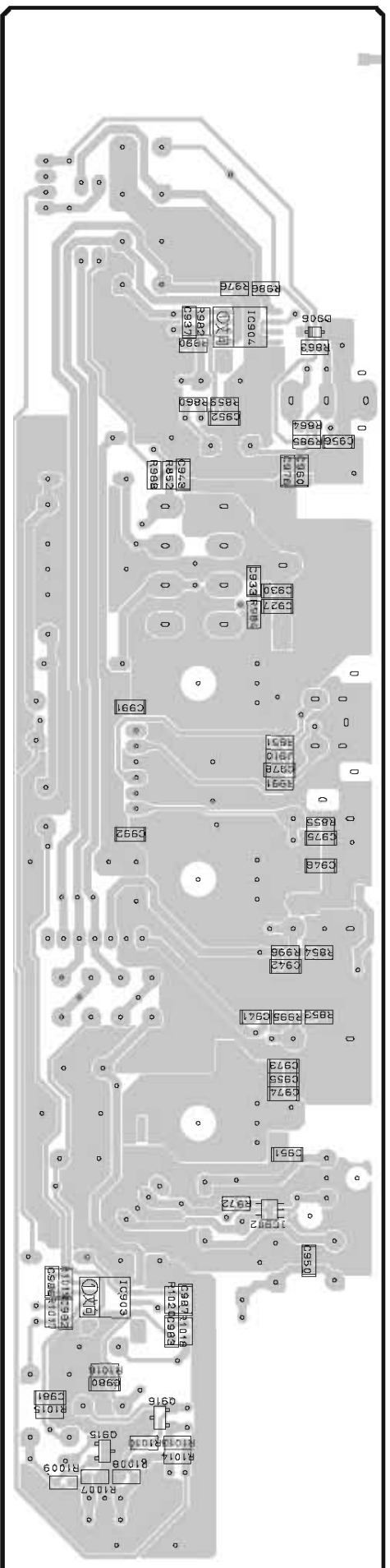

Circuit No.	U, C, J	R, T, K, A, B, G, L
C978	O	X
J910	X	O

X : NOT USED
O : USED/APPLICABLE

• Semiconductor Location

Ref.no.	Location
D906	C5
D932	F3
D933	F3
IC902	G5
IC903	G6
IC904	C6
O915	H6
O916	H6

PRINTED CIRCUIT BOARD

OPERATION (6) P.C.B.
(Side A)

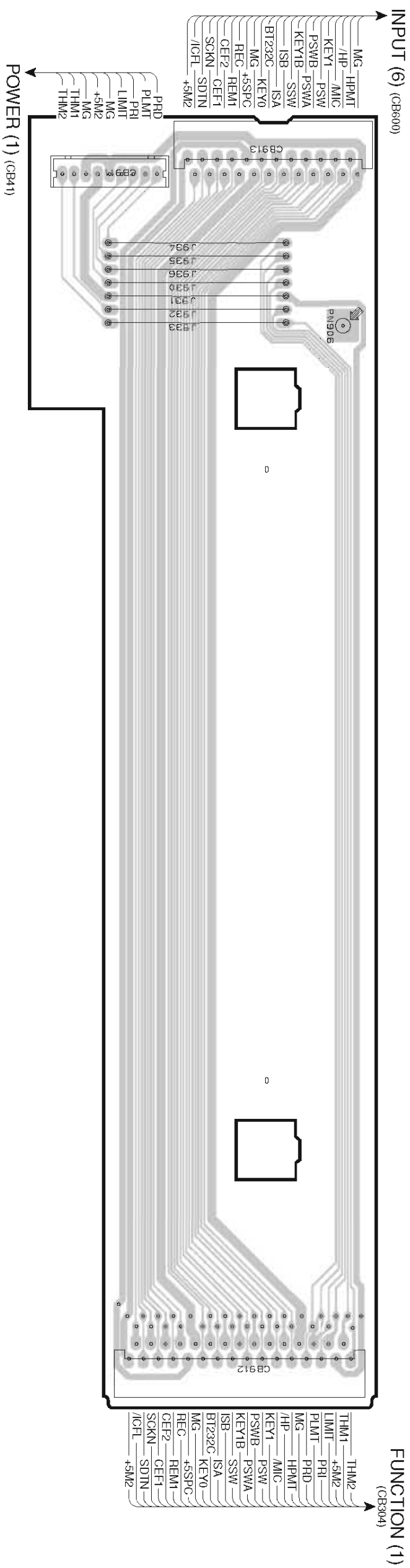

1 ■ PRINTED CIRCUIT BOARD Lead Free Solder Used

MAIN (1) P.C.B. (Side A)

MAIN (2) P.C.B. (Side A)

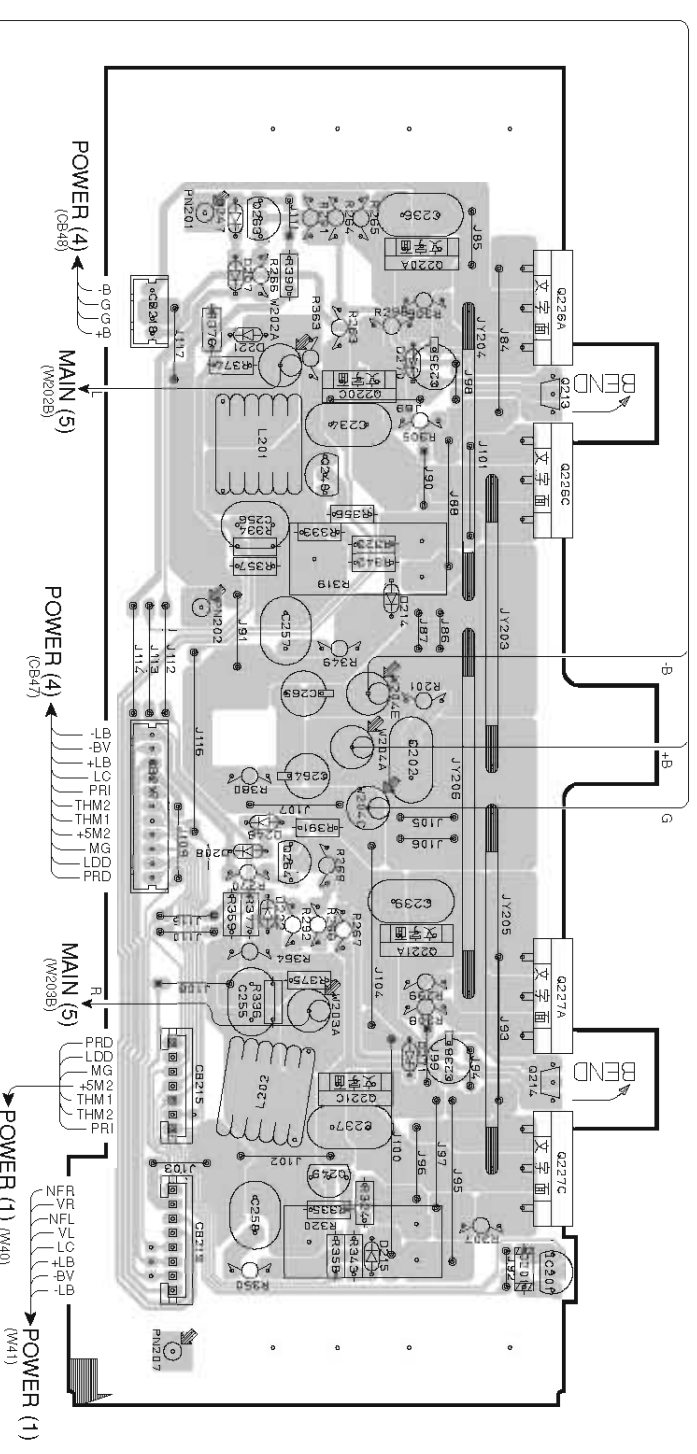
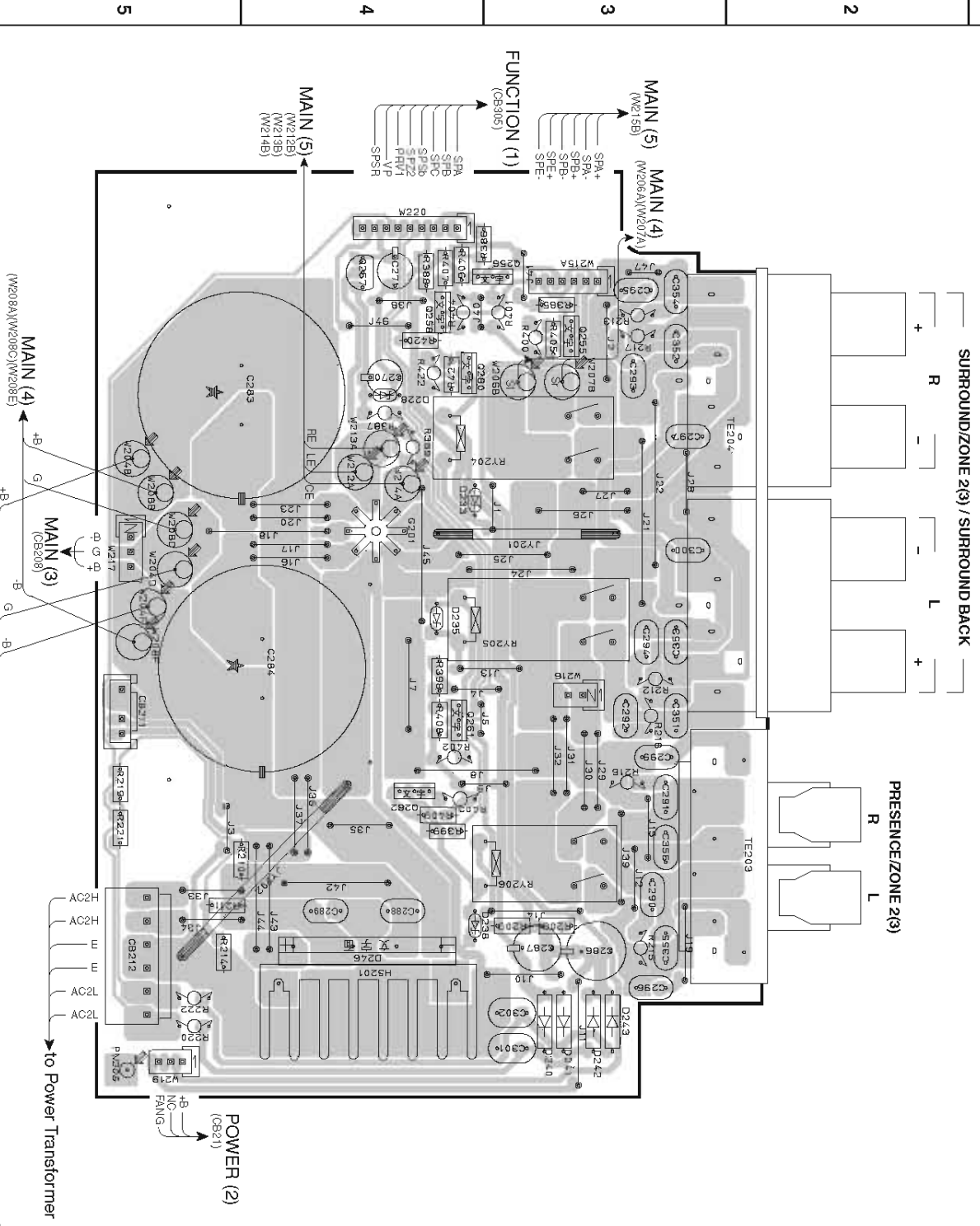

• Semiconductor Location

Ref.no.	Location	Ref.no.	Location	Ref.no.	Location
D207	G4	D246	E3	Q227A	I3
D208	I4	D247	F4	Q227C	J3
D214	H4	D248	H4	Q248	G4
D215	J4	D270	G4	Q249	J4
D221	G4	D271	I4	Q255	B3
D222	I4	IC201	J3	Q256	B3
D228	B4	Q213	G3	Q257	B4
D233	C4	Q214	I3	Q258	B4
D235	C4	Q220A	G4	Q261	D4
D238	E4	Q220C	G4	Q262	D4
D240	E3	Q221A	I4	Q263	F4
D241	E3	Q221C	I4	Q264	I4
D242	E3	Q226A	G3	Q280	B4
D243	E3	Q226C	G3		

■ PRINTED CIRCUIT BOARD Lead Free Solder Used

MAIN (3) P.C.B. (Side A)

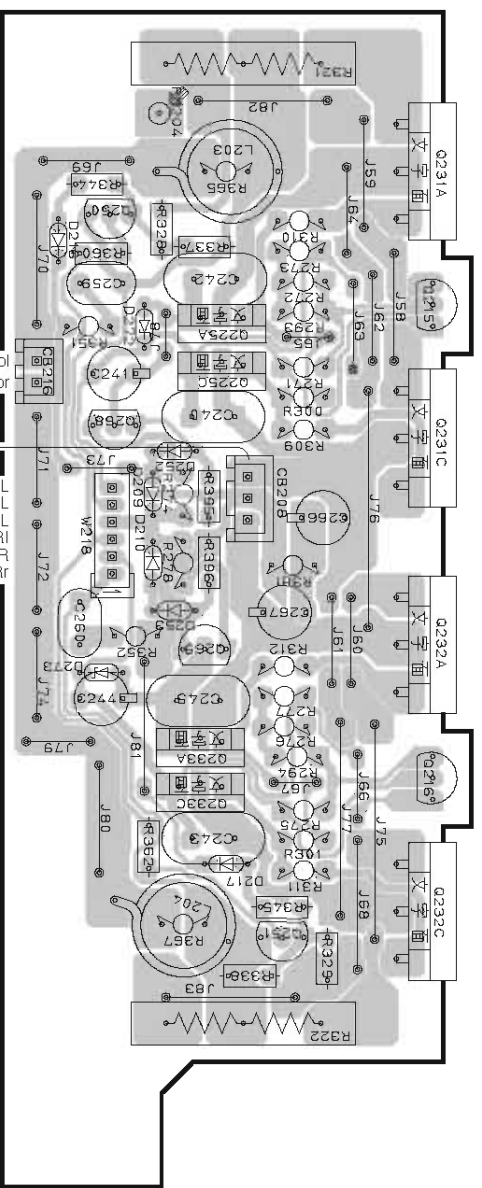

MAIN (5) P.C.B. (Side A)

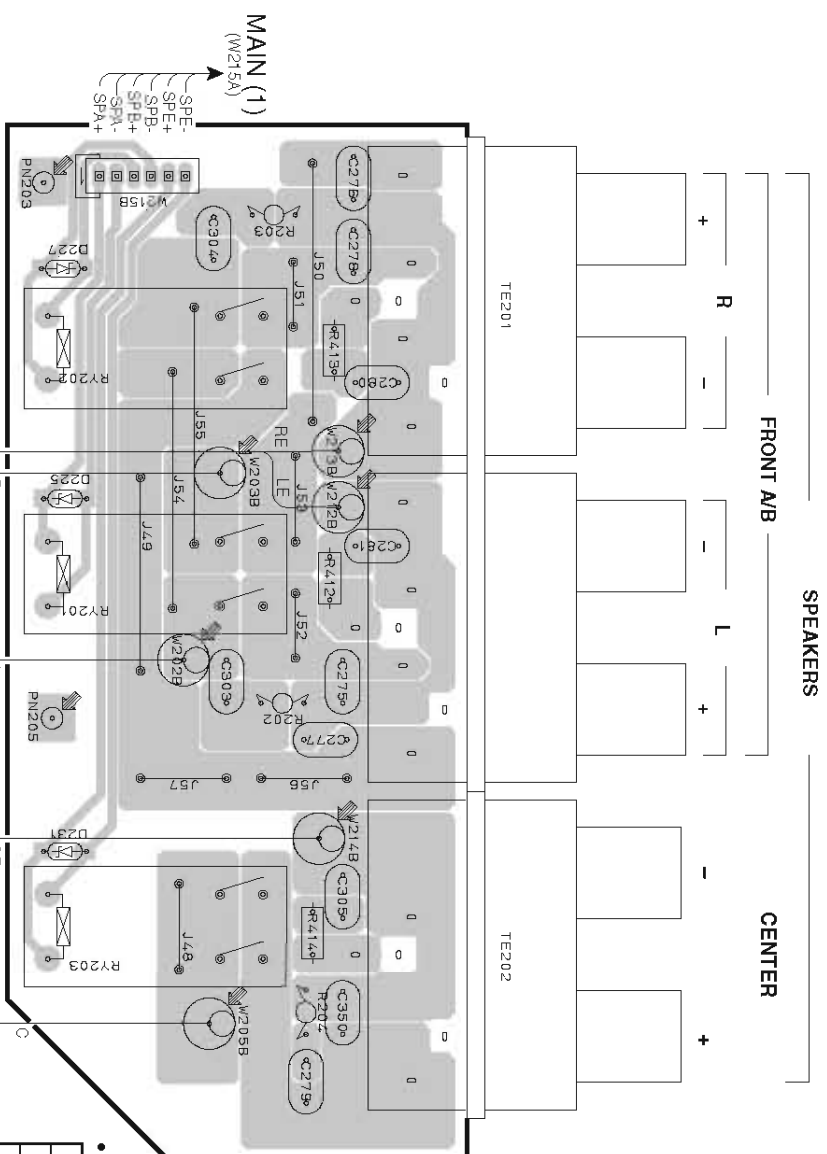

MAIN (4) P.C.B. (Side A)

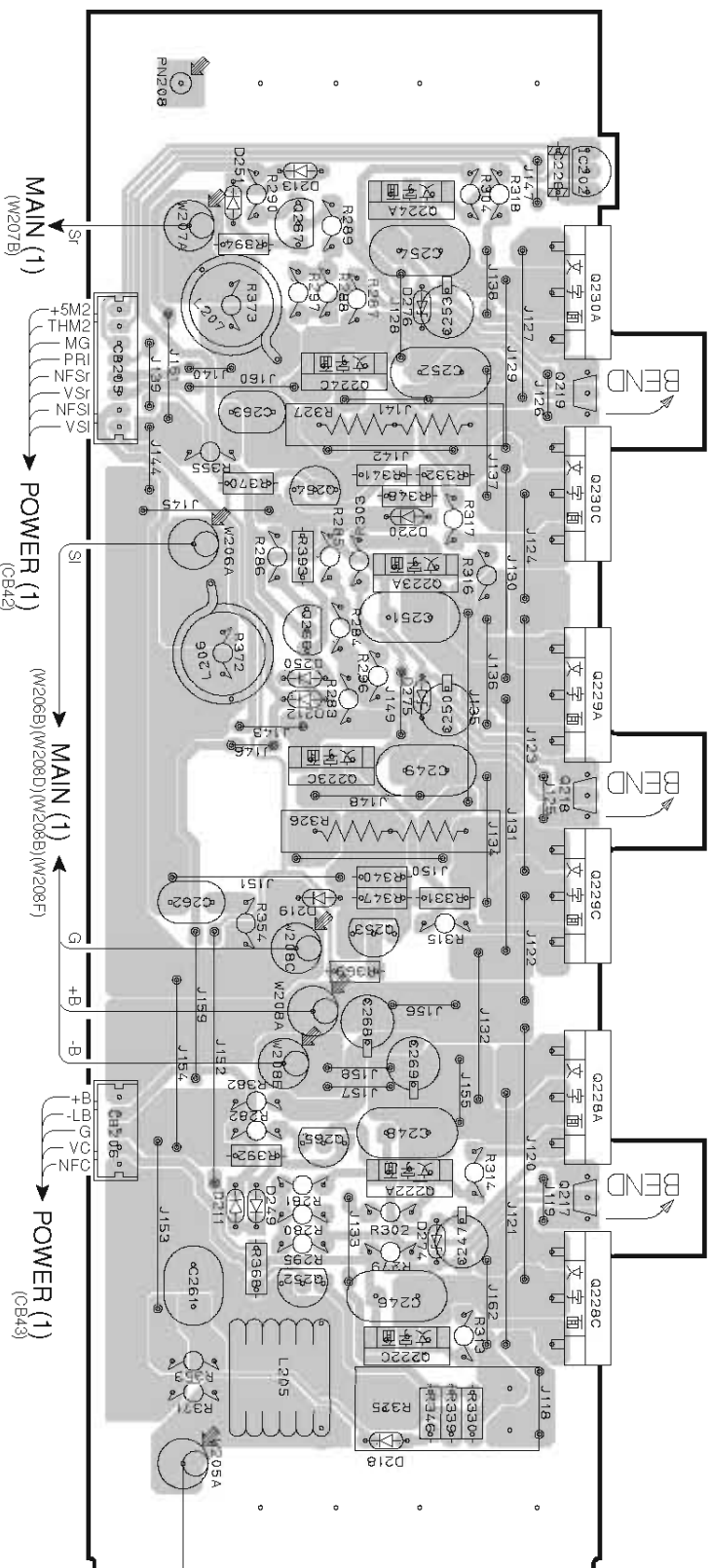

• Semiconductor Location

Ref.no.	Location	Ref.no.	Location
D209	B3	Q222C	E5
D210	C3	Q223A	C5
D211	E6	Q223C	C6
D212	C6	Q224A	A5
D213	A6	Q224C	B6
D216	B3	Q225A	B3
D217	D2	Q225C	B3
D218	F6	Q228A	E5
D219	D6	Q228C	E5
D220	C5	Q229A	C5
D225	G4	Q229C	D5
D227	F4	Q230A	B5
D231	H4	Q230C	B5
D249	E6	Q231A	A2
D250	C6	Q231C	B2
D251	B6	Q232A	C2
D252	B3	Q232C	D2
D253	C3	Q233A	C3
D272	B3	Q233C	C3
D273	C3	Q250	B3
D274	C5	Q251	D2
D275	C5	Q252	E6
D276	B5	Q253	D6
IC202	A5	Q254	B6
Q215	B2	Q265	E6
Q216	C6	Q266	C6
Q217	E5	Q267	B6
Q218	D5	Q268	B3
Q219	B5	Q269	C3
Q222A	E5		

1 ■ PRINTED CIRCUIT BOARD

POWER (1) P.C.B. (Side A)

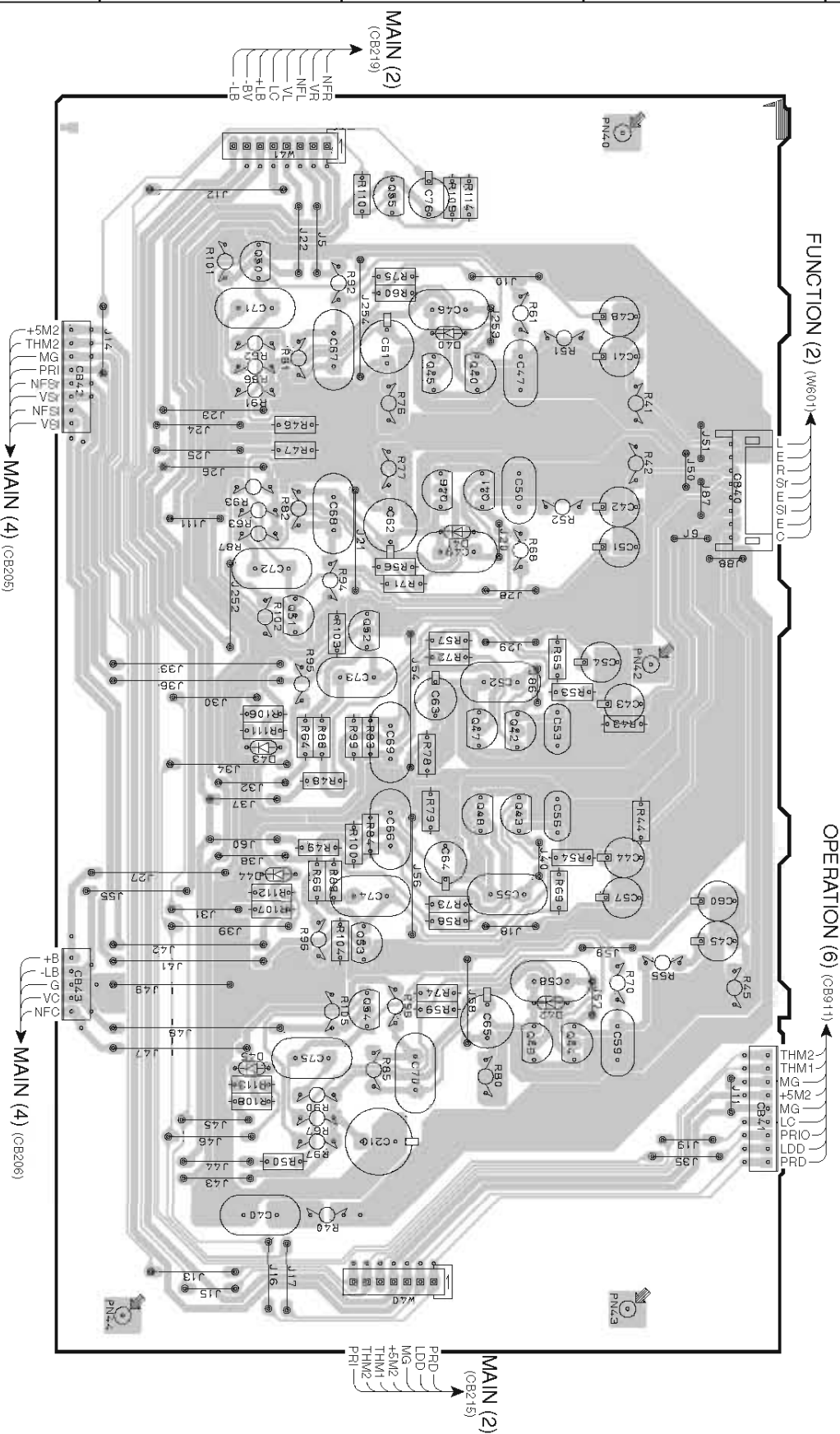

Circuit No.	U, C, T, K, A, B, G, J	R, L
CB8	X	O
CB9	X	O
CB10, CB11	X	O
F3	X	O
J6, J7, J8	X	O
SW1	X	O
W3A, W3B	X	O

X : NOT USED
O : USED/APPLICABLE

POWER (6) P.C.B. (Side A)

R, L models

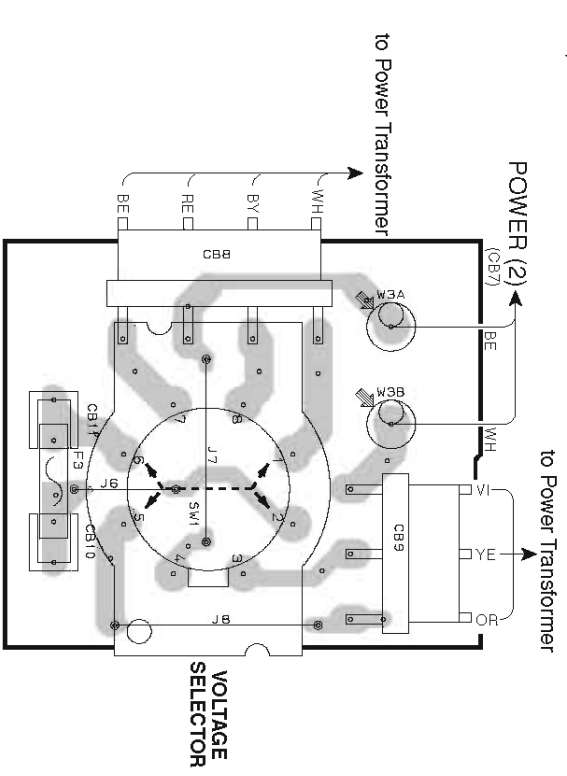

• Semiconductor Location

Refno.	Location
D40	B3
D41	C3
D42	E3
D43	D4
D44	D4
D45	E4
D323	H6
IC317	E5
IC318	E5
IC319	E5
IC320	F5
Q40	B3
Q41	C3
Q42	D3
Q43	D3
Q44	E3
Q45	B3
Q46	C3
Q47	D3
Q48	D3
Q49	E3
Q50	B4
Q51	C4
Q52	C3
Q53	E3
Q54	E3
Q55	B3
Q319	G6
Q320	G7
Q321	E6
Q323	H6

POWER (7) P.C.B. (Side A)

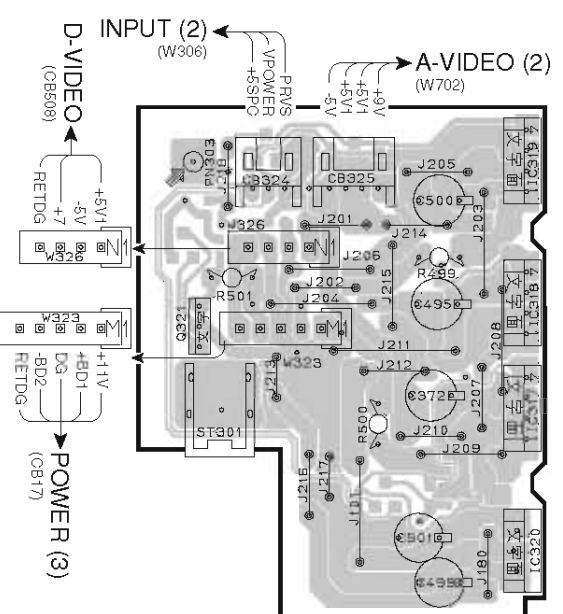

POWER (7) P.C.B. (Side B) Lead Free Solder Used

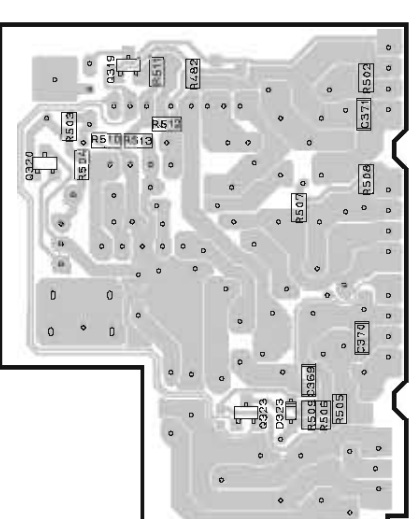

A B C D E F G H I J

7

PRINTED CIRCUIT BOARD

POWER (2) P.C.B. (Side A)

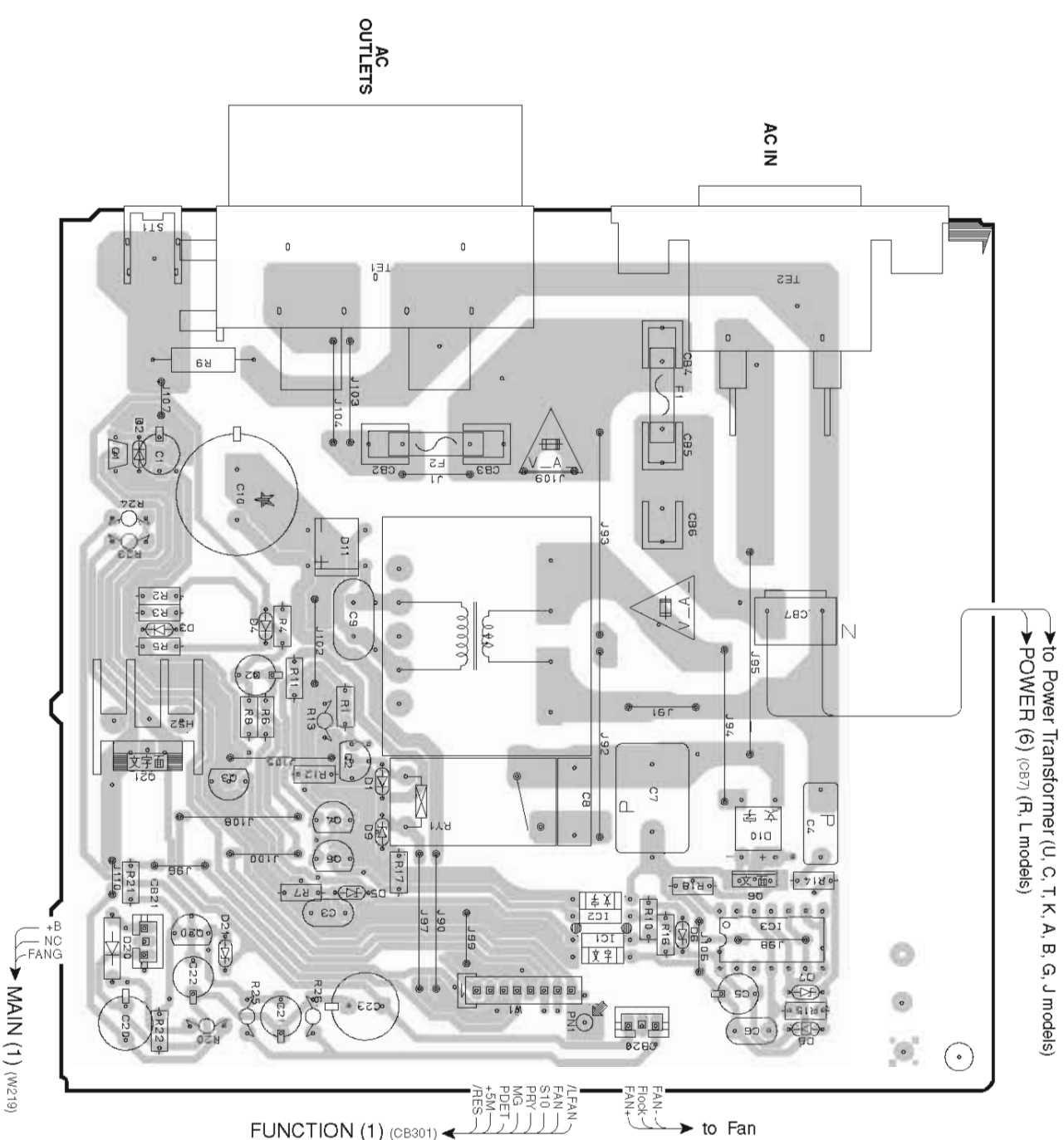

POWER (3) P.C.B. (Side A)

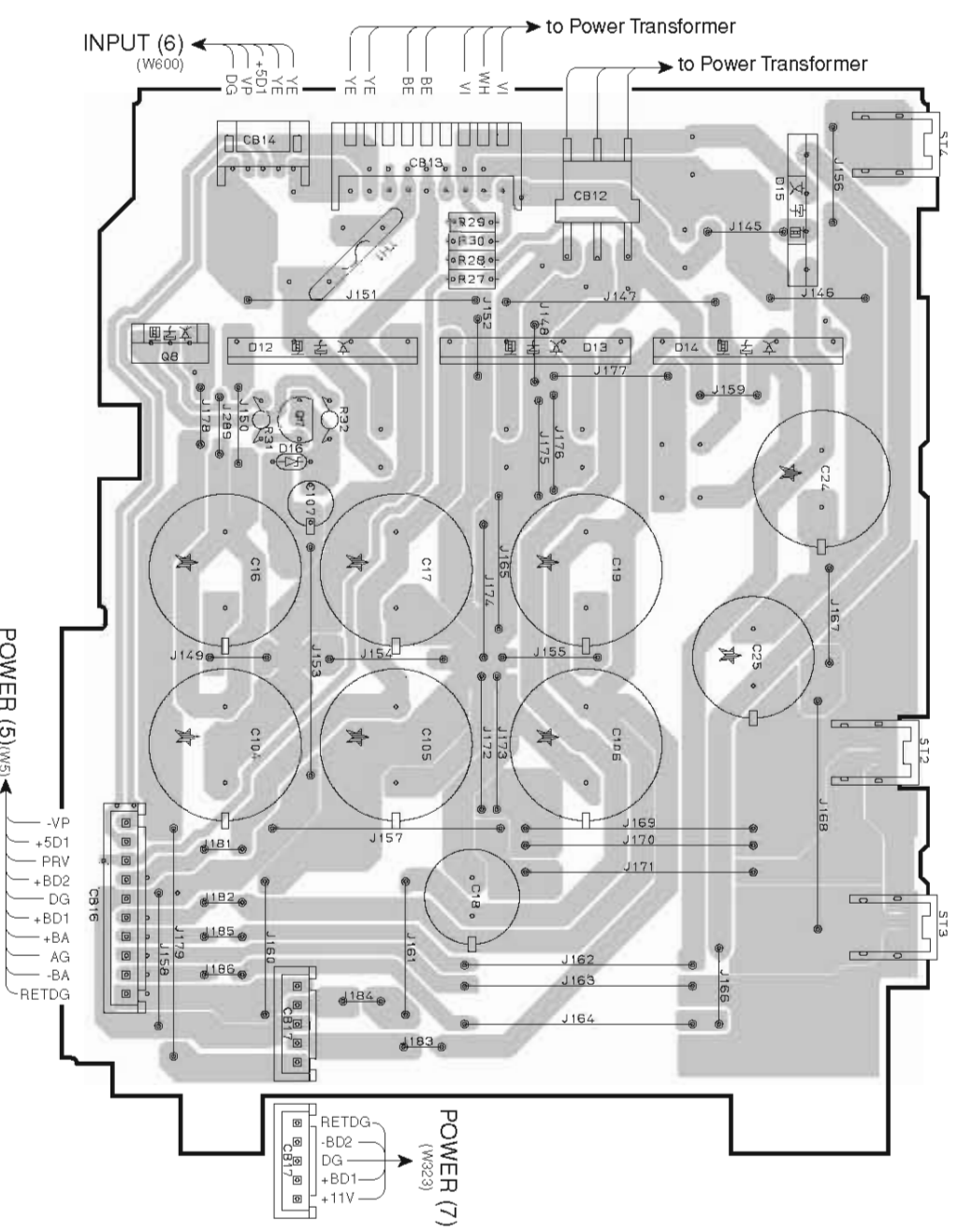

Circuit No.	U, C	R, L	J, T, A, B	K	G
CB2, CB3	O	X	X	X	O
CB5	X	X	O	O	O
CB6	O	O	X	X	X
F2	O	X	X	X	O
J1	X	O	O	O	X
R9	O	X	X	X	X
TE1	O	O	O	X	O

X : NOT USED
O : USED/APPLICABLE

• Semiconductor Location

Ref.no.	Location	Ref.no.	Location	Ref.no.	Location
D1	D4	D12	G4	Q2	D4
D2	C5	D13	G3	Q3	D5
D3	C5	D14	G3	Q4	D5
D4	C5	D15	F2	Q5	D5
D5	D4	D16	G4	Q6	D3
D6	D3	D20	D5	Q7	G4
D7	E3	D21	E5	Q8	G5
D8	E3	IC-1	E3	Q20	D5
D9	D4	IC2	D3	Q21	D5
D10	D3	IC3	D3		
D11	C5	Q1	C5		

PRINTED CIRCUIT BOARD

POWER (4) P.C.B. (Side A)

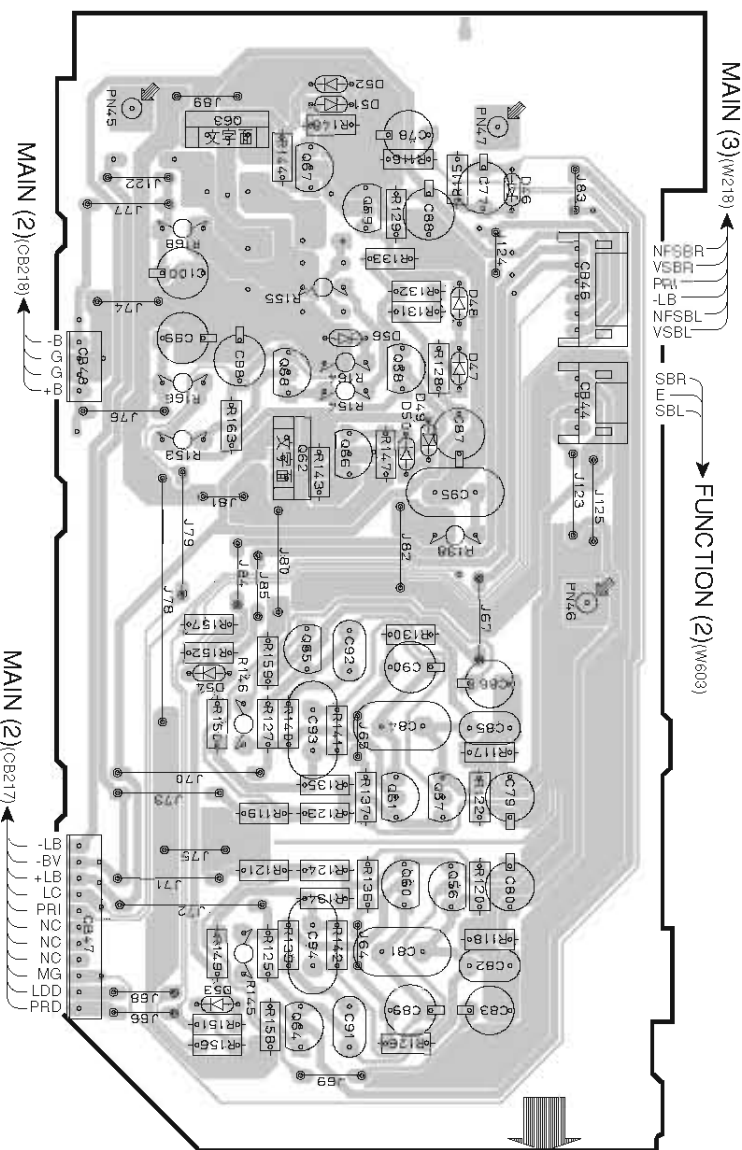

Circuit No.	U, C	R, T, K, A, B, G, L, J
C33, 103	O	X
C101	O	X
C108	O	X
D28	O	X
D31	O	X
IC7	O	X
Q18	O	X
R19	O	X
R169	O	X
R180	O	X
R181	O	X

X : NOT USED
O : USED/APPLICABLE

Semiconductor Location

Ref.no.	Location	Ref.no.	Location
D19	G5	Q10	F5
D22	F5	Q11	F5
D23	H5	Q12	H5
D24	H5	Q13	G2
D28	G5	Q14	G2
D30	I5	Q15	F2
D31	G5	Q16	H2
D46	B2	Q17	H5
D47	B3	Q18	G5
D48	B3	Q56	D3
D49	C3	Q57	D3
D50	C3	Q58	B3
D51	A3	Q59	B3
D52	A3	Q60	D3
D53	E3	Q61	D3
D54	C4	Q62	C3
D56	B3	Q63	B3
IC4	H2	Q64	E3
IC5	I2	Q65	C3
IC6	I2	Q66	C3
IC7	G2	Q67	B3
Q9	G5	Q68	B3

POWER (5) P.C.B. (Side A)

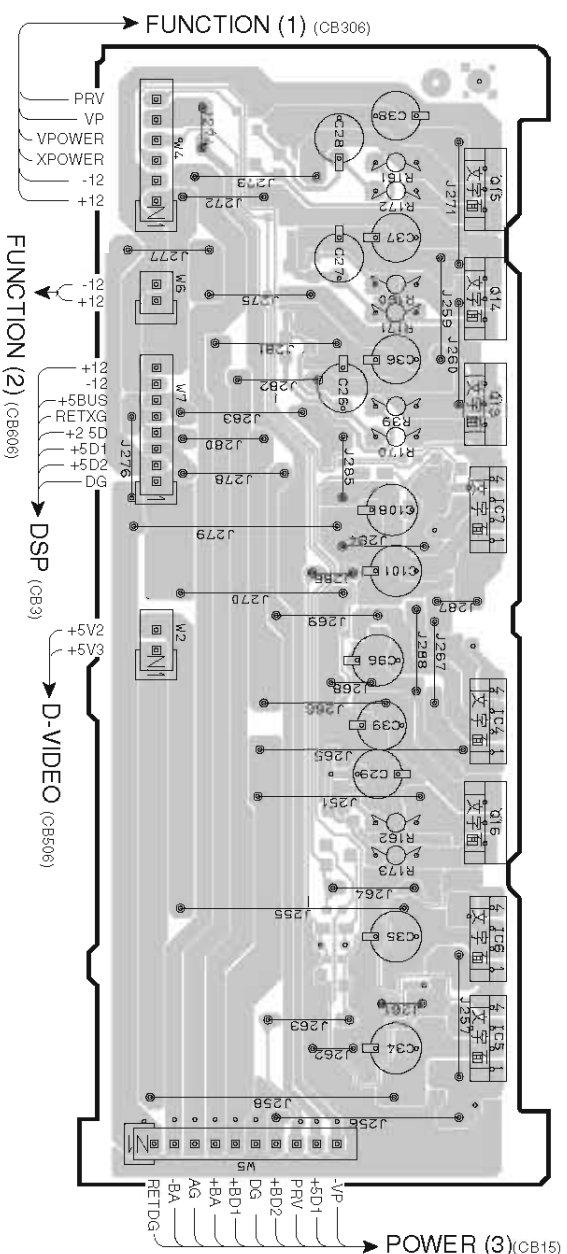

POWER (5) P.C.B. (Side B) Lead Free Solder Used

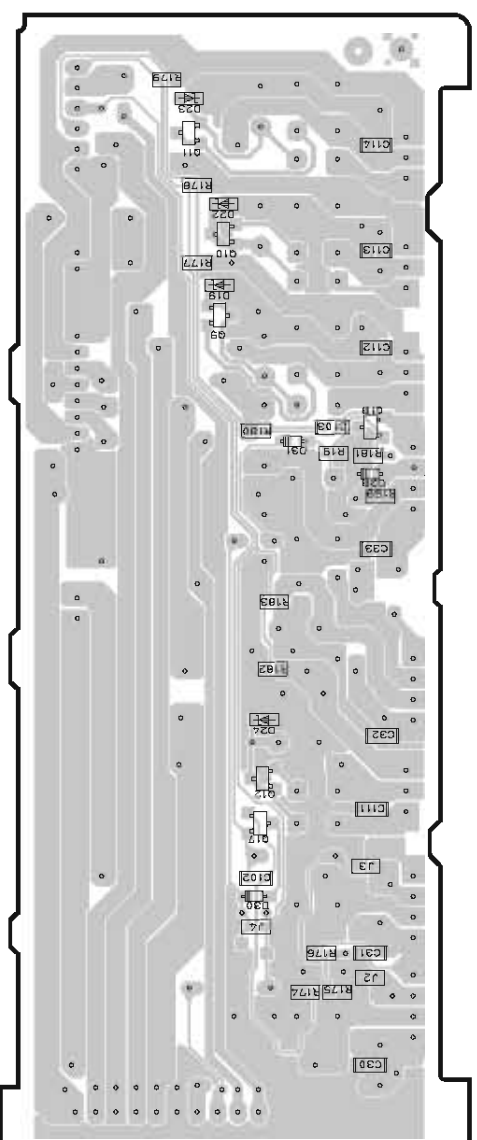

PRINTED CIRCUIT BOARD

INPUT (1) P.C.B. (Side A) Lead Free Solder Used

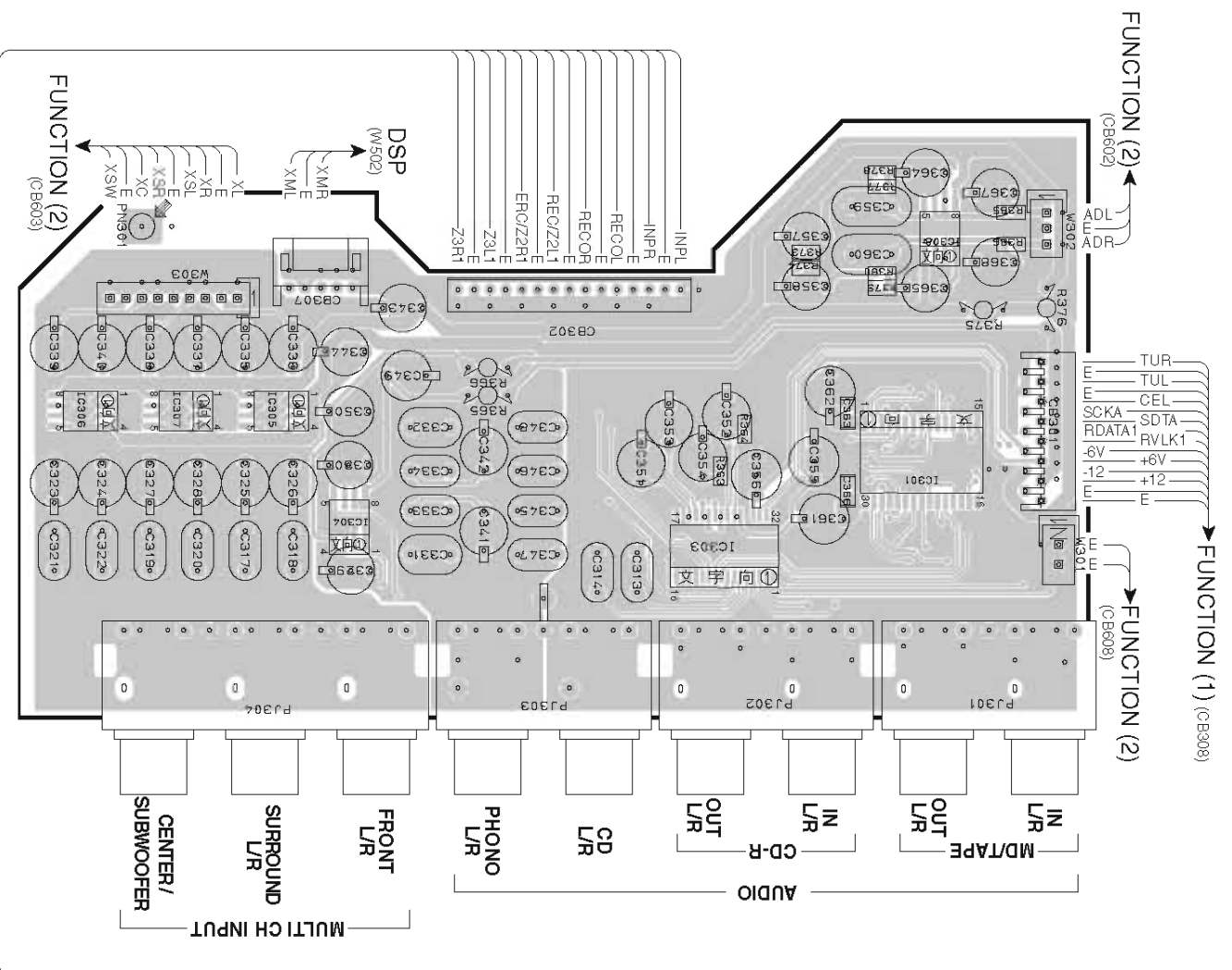

INPUT (4) P.C.B. (Side A) Lead Free Solder Used

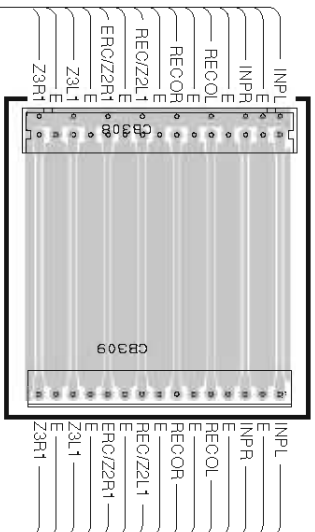

INPUT (5) P.C.B. (Side A) Lead Free Solder Used

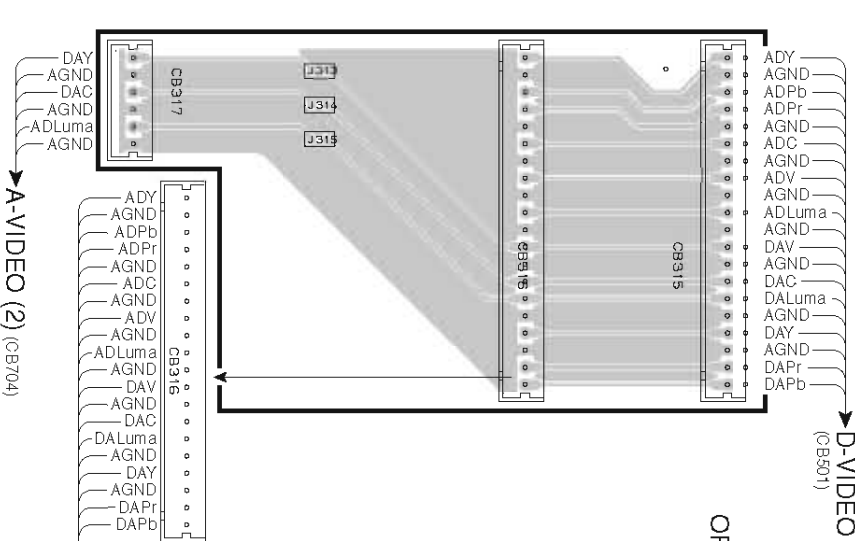

INPUT (2) P.C.B. (Side A) Lead Free Solder Used

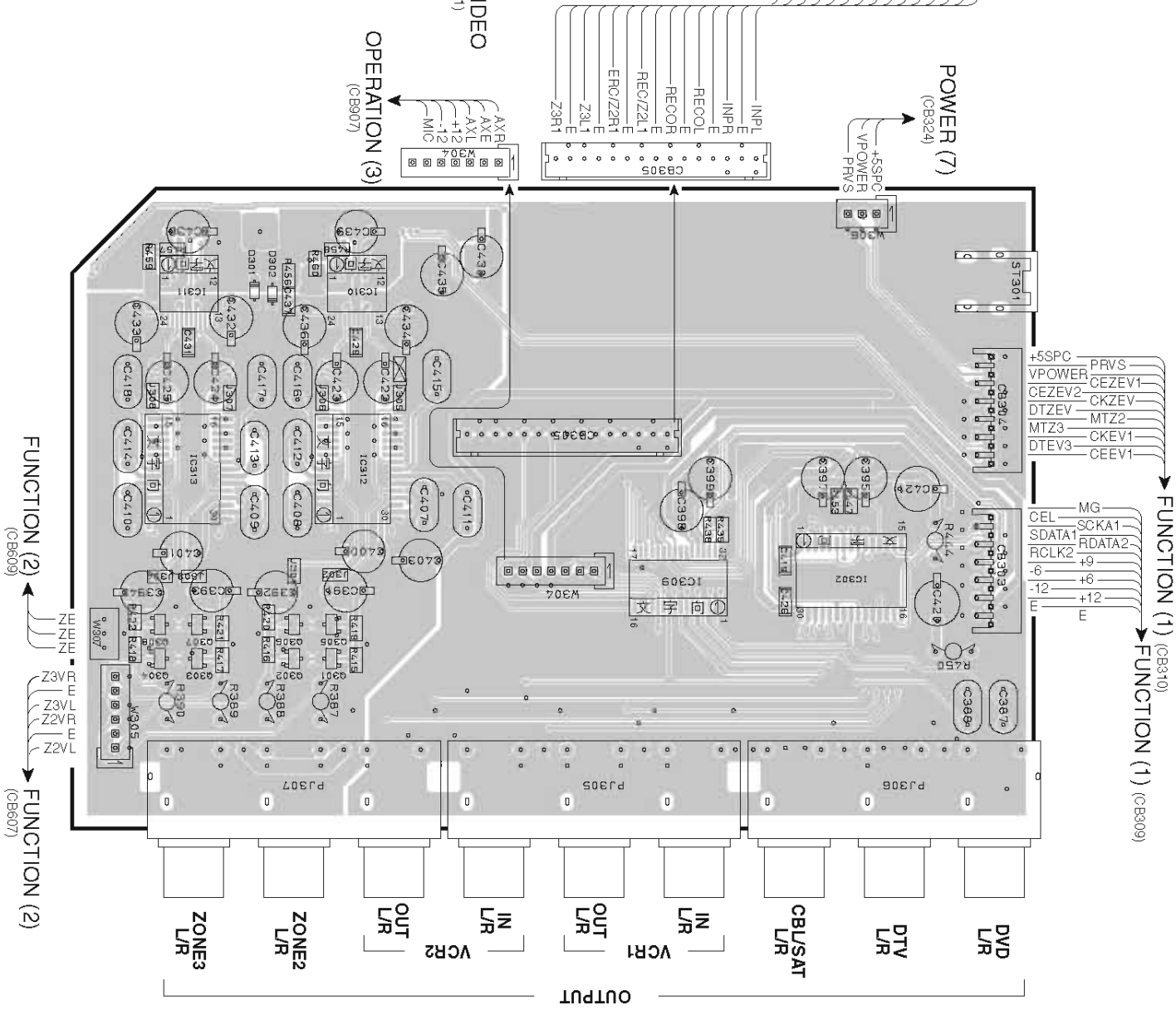

Semiconductor Location

Ref.no.	Location	Ref.no.	Location	Ref.no.	Location	Ref.no.	Location
D301	G5	IC303	C4	IC307	B6	IC311	G5
D302	G5	IC304	C5	IC308	B3	IC312	H5
IC301	B3	IC305	B5	IC309	I3	IC313	H5
IC302	I3	IC306	B6	IC310	G5	Q301	I5
						Q305	I5
						Q302	I5
						Q303	I5
						Q304	I5
						Q307	I5
						Q308	I5

Circuit No.

Circuit No.	U.C	R.T.K.A.B.G.L	J
CB807	X	X	X
PJ301, 302, 308	O	O	O
PJ303	O	O	O
PJ304	O	O	O
PJ305-307	O	O	O
X7100	O	O	O

X : NOT USED
O : USED/APPLICABLE

A B C D E F G H I J

1 ■ PRINTED CIRCUIT BOARD

INPUT (1) P.C.B. (Side B) Lead Free Solder Used

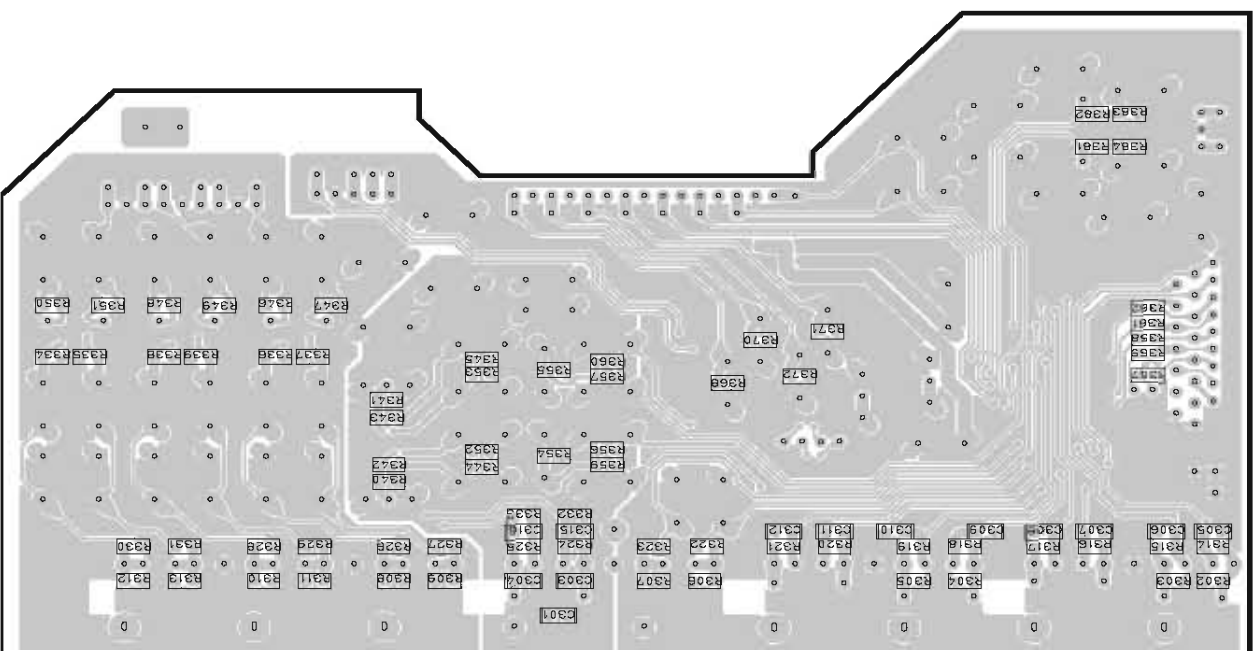

INPUT (4) P.C.B. (Side B)
Lead Free Solder Used

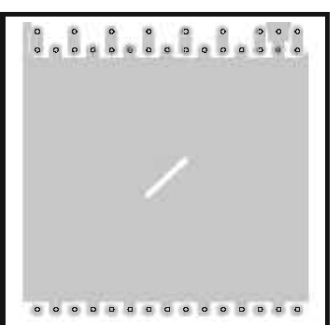

INPUT (5) P.C.B. (Side B)
Lead Free Solder Used

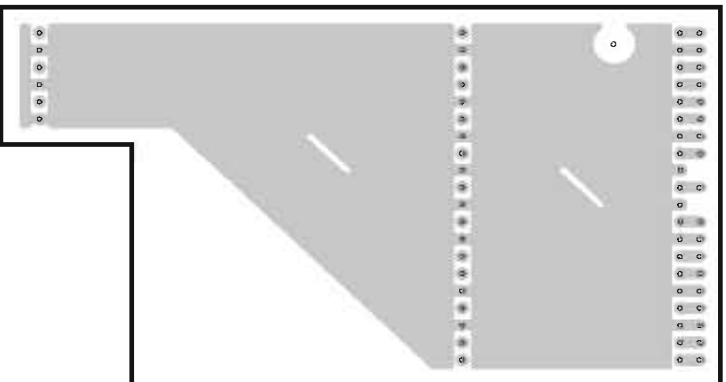

INPUT (2) P.C.B. (Side B) Lead Free Solder Used

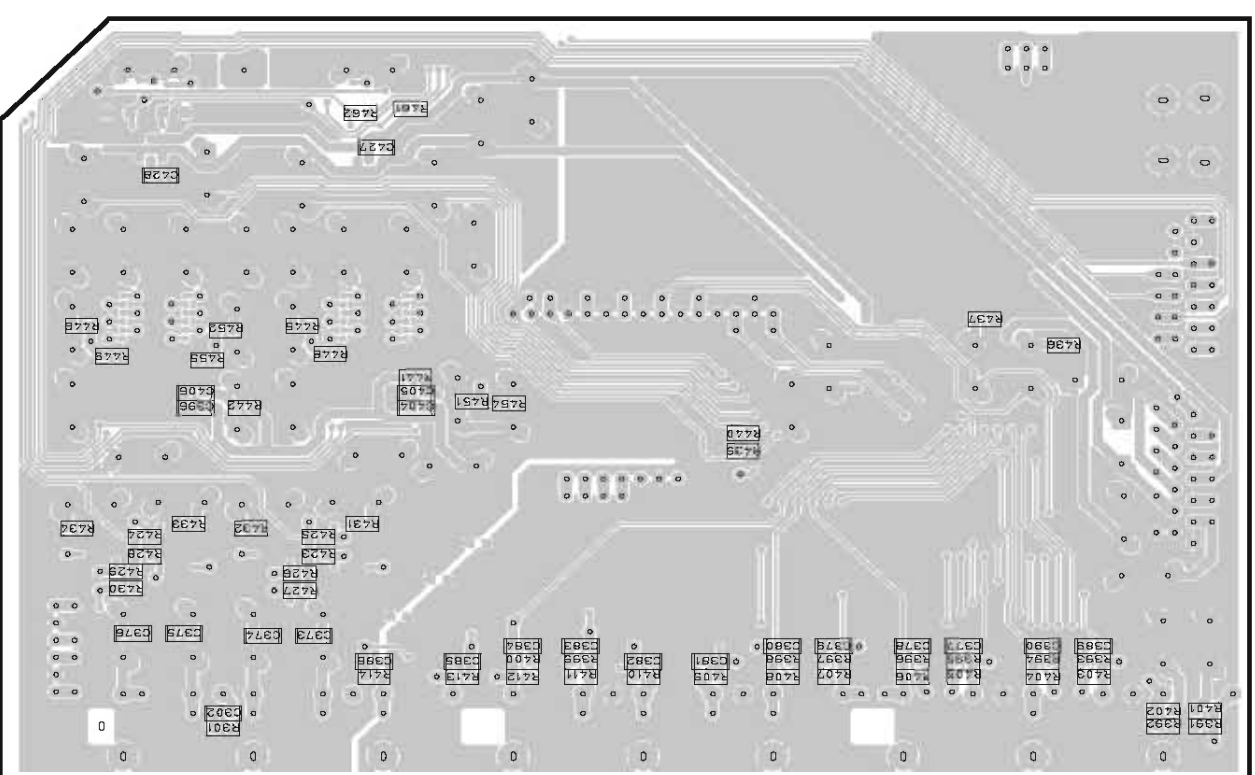

Circuit No.	U.C	R, T, K, A, B, G, L	J
C303, 304	X	O	X
R324, 325	O	O	O
X7100	O	O	O

X : NOT USED
O : USED/APPLICABLE

7

6

5

4

3

2

1

PRINTED CIRCUIT BOARD

INPUT (3) P.C.B. (Side A) Lead Free Solder Used

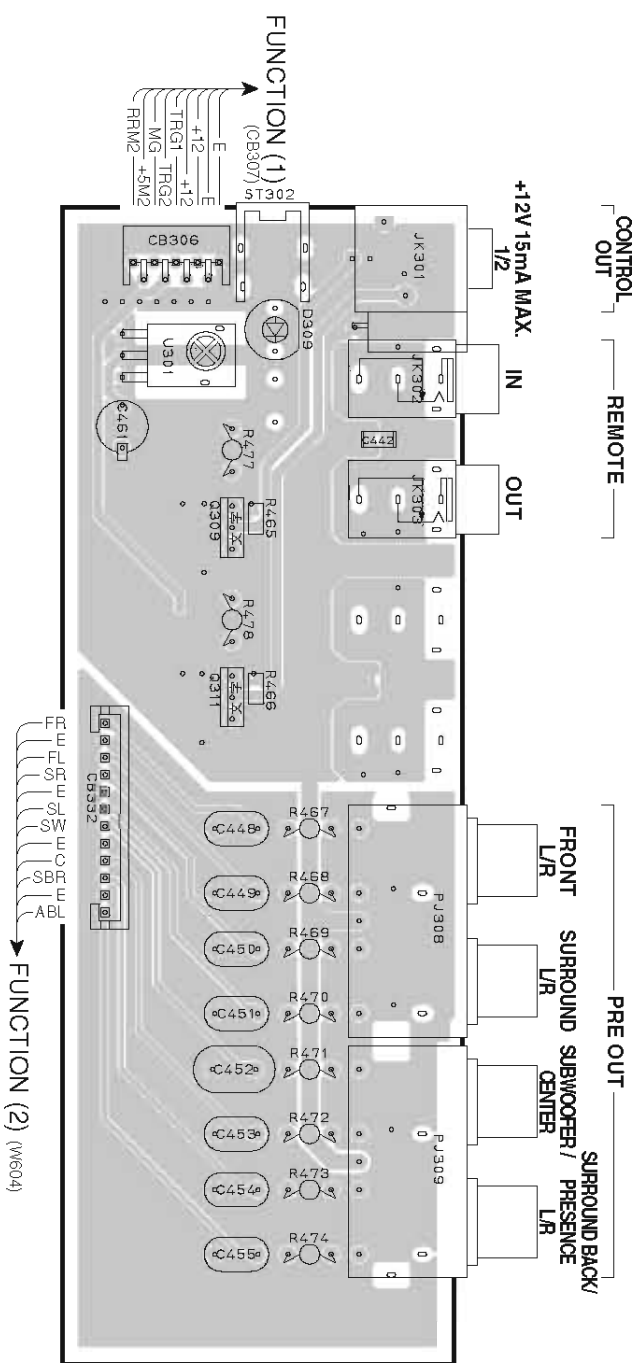

Semiconductor Location

Ref no.	Location
D309	B3
Q309	C3
Q311	D3

INPUT (6) P.C.B. (Side A) Lead Free Solder Used

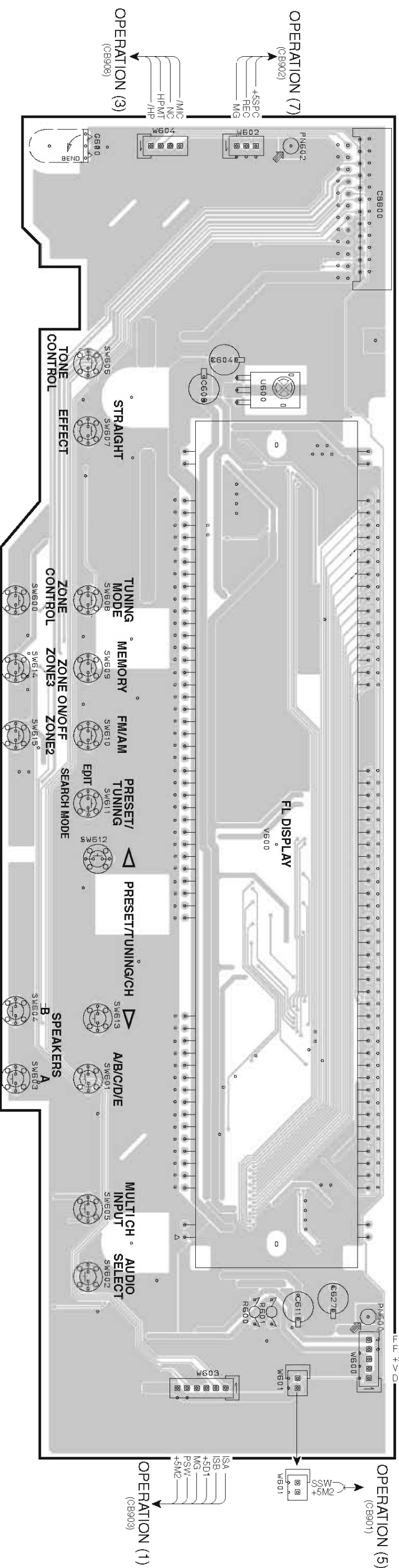
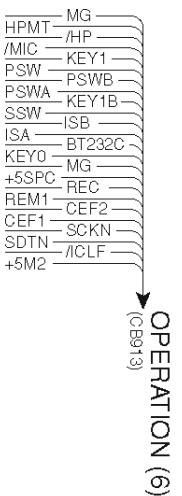

1 ■ PRINTED CIRCUIT BOARD

INPUT (3) P.C.B. (Side B) Lead Free Solder Used

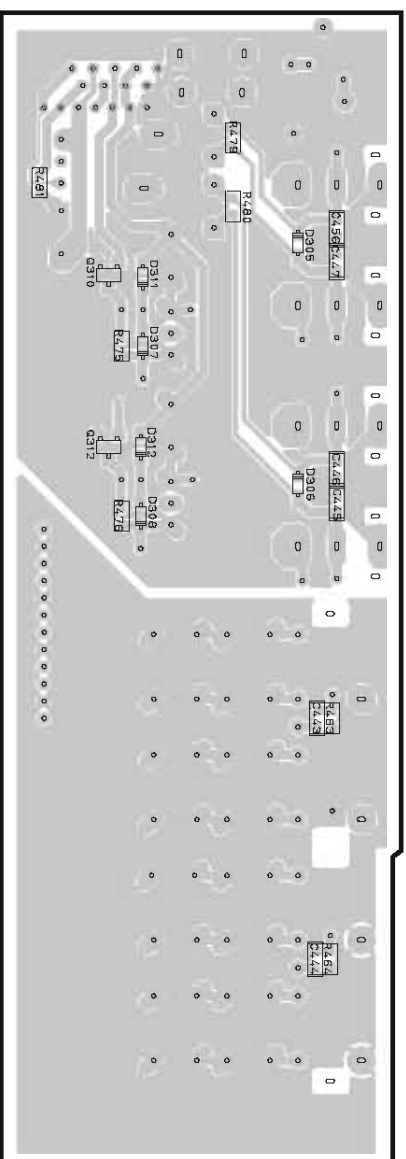

• Semiconductor Location

Ref no.	Location	Ref no.	Location	Ref no.	Location	Ref no.	Location
D305	B2	D608	E6	IC601	G5	Q605	F5
D306	C2	D611	E6	Q310	B3	Q606	F5
D307	C3	D612	E6	Q312	C3	Q607	F5
D308	C3	D613	E6	Q600	G5	Q608	F5
D311	B3	D614	E6	Q601	C5	Q609	E6
D312	C3	D615	E6	Q602	F5		
D600	I5	D616	E6	Q603	F5		
D601	I5	IC600	D5	Q604	F5		

INPUT (6) P.C.B. (Side B) Lead Free Solder Used

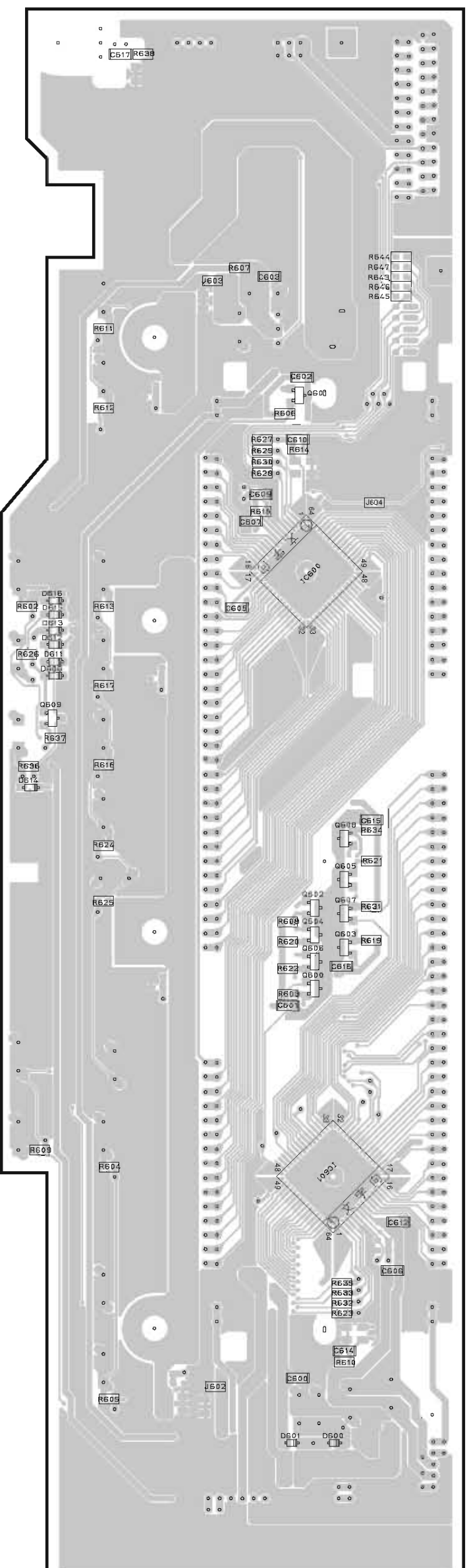

7

6

5

4

3

2

1

A B C D E F G H I J

PRINTED CIRCUIT BOARD

A-VIDEO (1) P.C.B. (Side A) Lead Free Solder Used

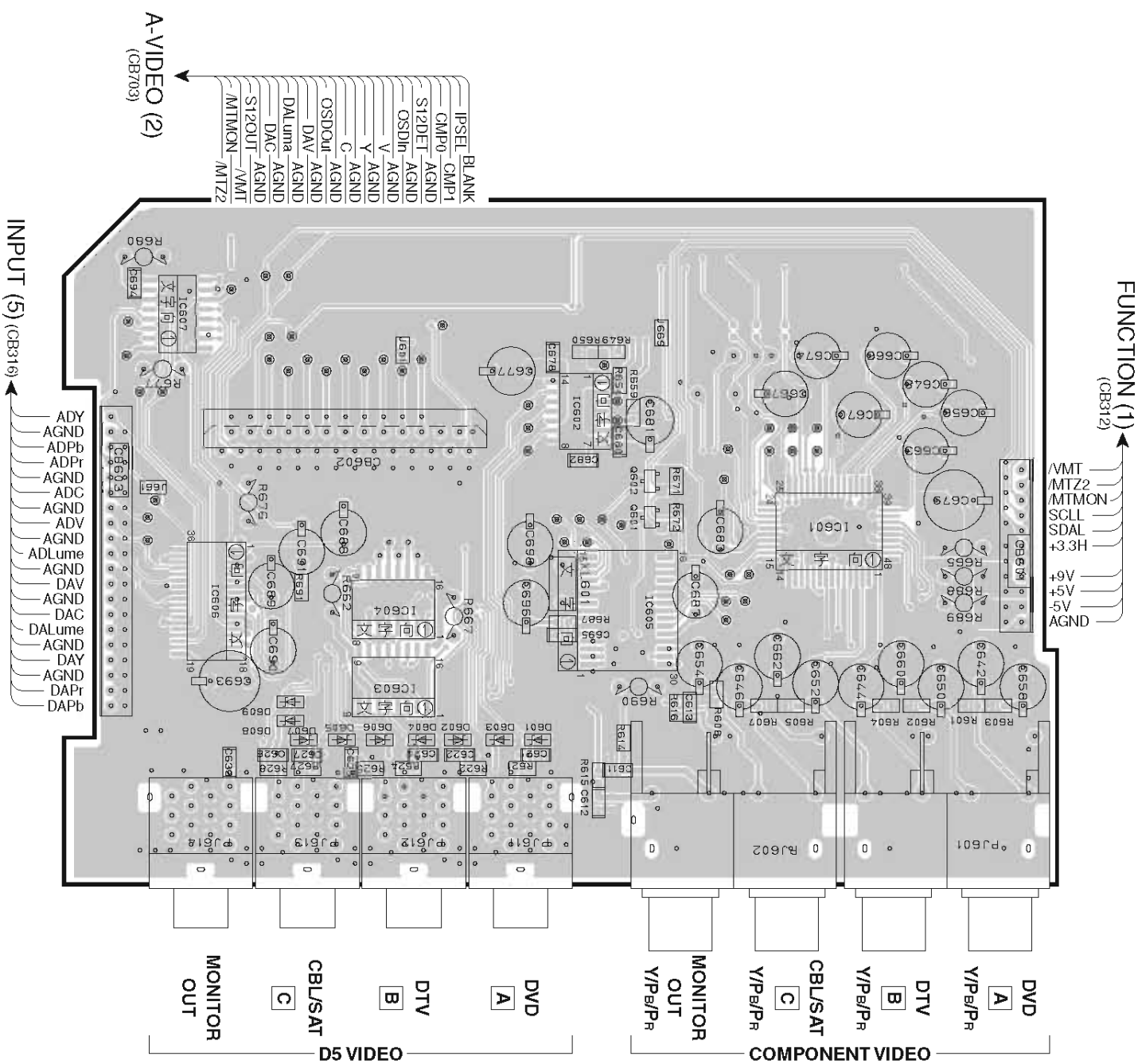

A-VIDEO (1) P.C.B. (Side B) Lead Free Solder Used

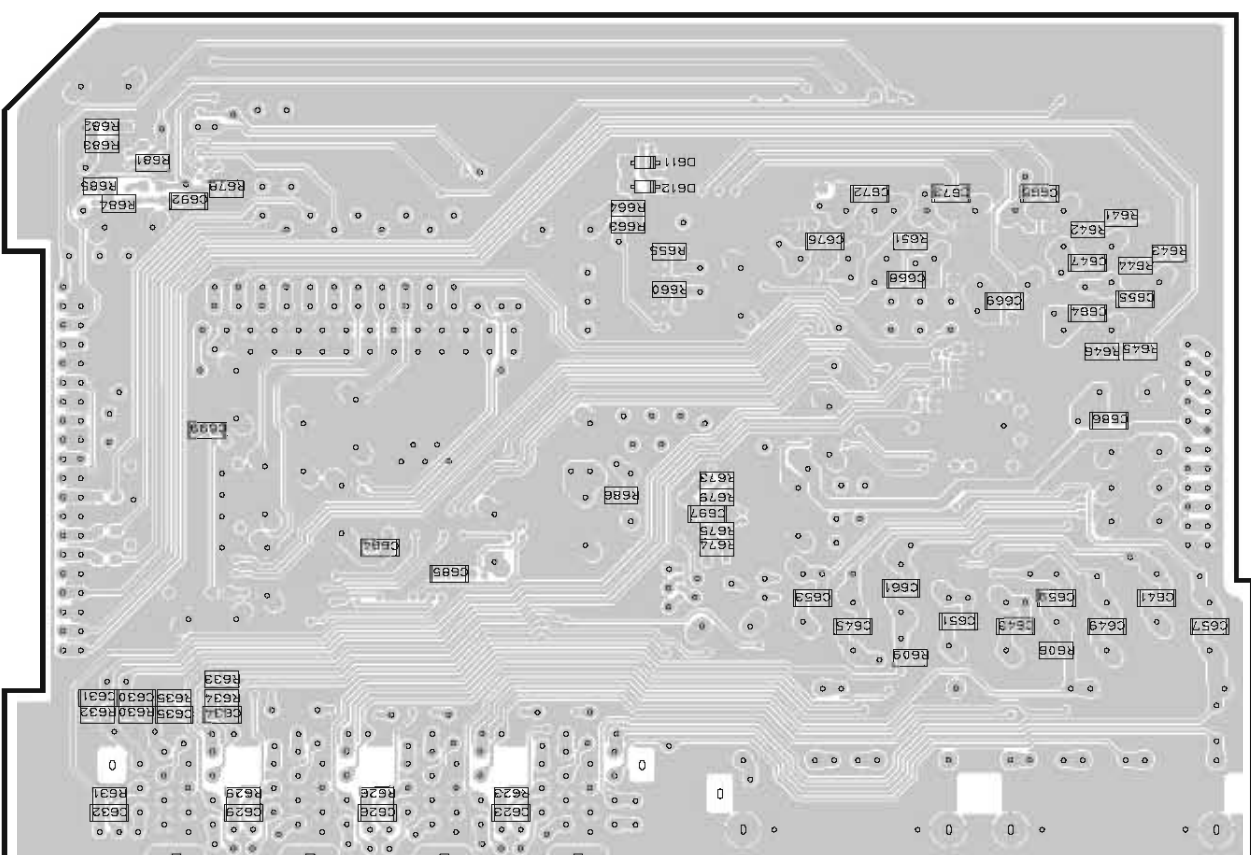

• Semiconductor Location

Ref.no.	Location	Ref.no.	Location
D601	D4	D612	G4
D602	D4	IC601	C3
D603	D4	IC602	C4
D604	D5	IC603	D5
D605	D5	IC604	C5
D606	D5	IC605	C4
D607	D5	IC606	C6
D608	D5	IC607	B6
D609	D5	Q601	C4
D611	F4	Q602	C4

Circuit No.	U, C, R, T, K, A, B, G, L	J	Circuit No.	U, C, R, T, K, A, B, G, L	J
C621-632	X	O	PJ611-614	X	O
C633-635	X	O	R621-629	X	O
C684, 685	X	O	R630-632	X	O
D601-609	X	O	R633-635	X	O
IC603, 604	X	O	R662, 667	X	O

X : NOT USED
O : USED/APPLICABLE

• Semiconductor Location

1 ■ PRINTED CIRCUIT BOARD

[A-VIDEO (2) P.C.B.] (Side A) Lead Free Solder Used

[A-VIDEO (2) P.C.B.] (Side B) Lead Free Solder Used

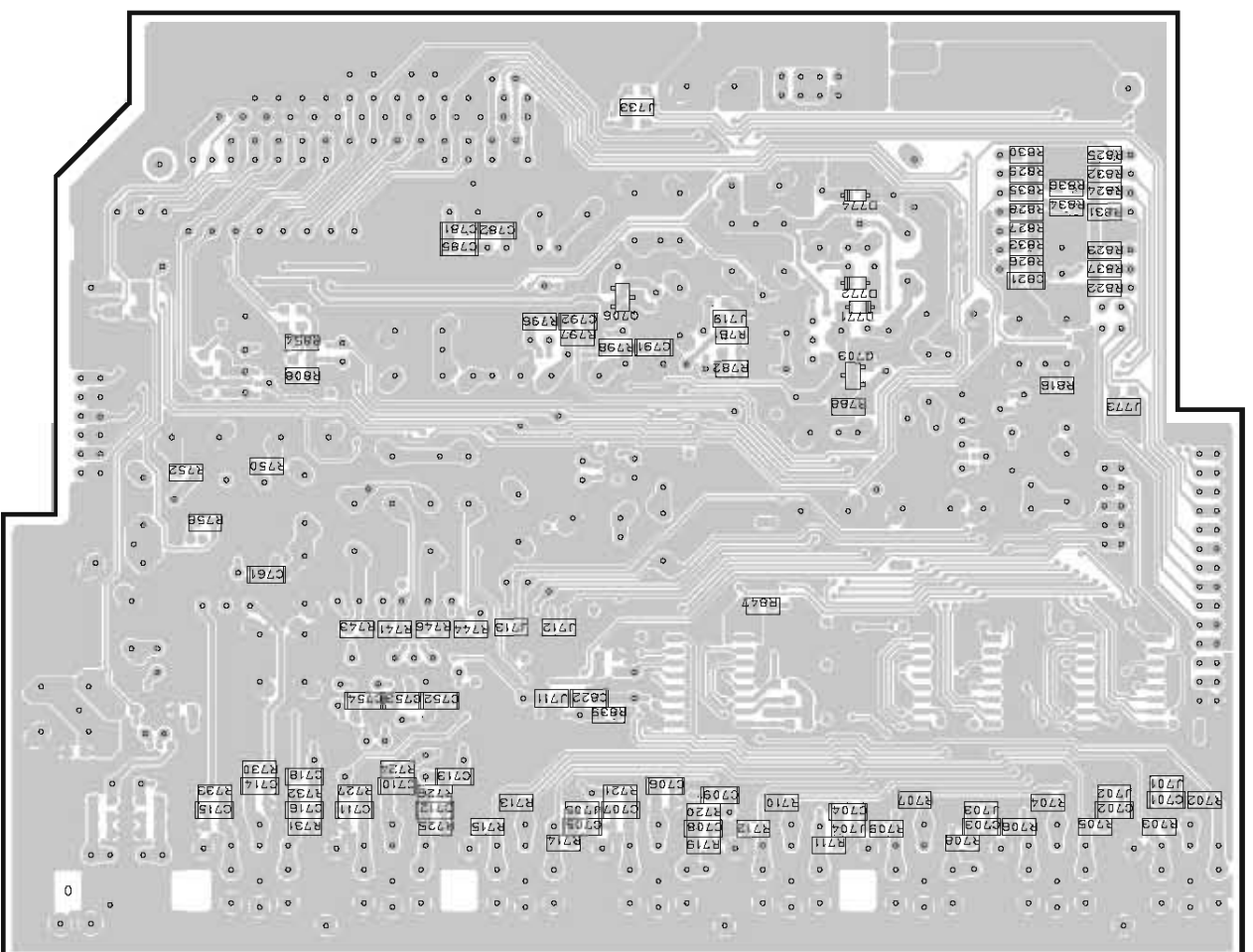
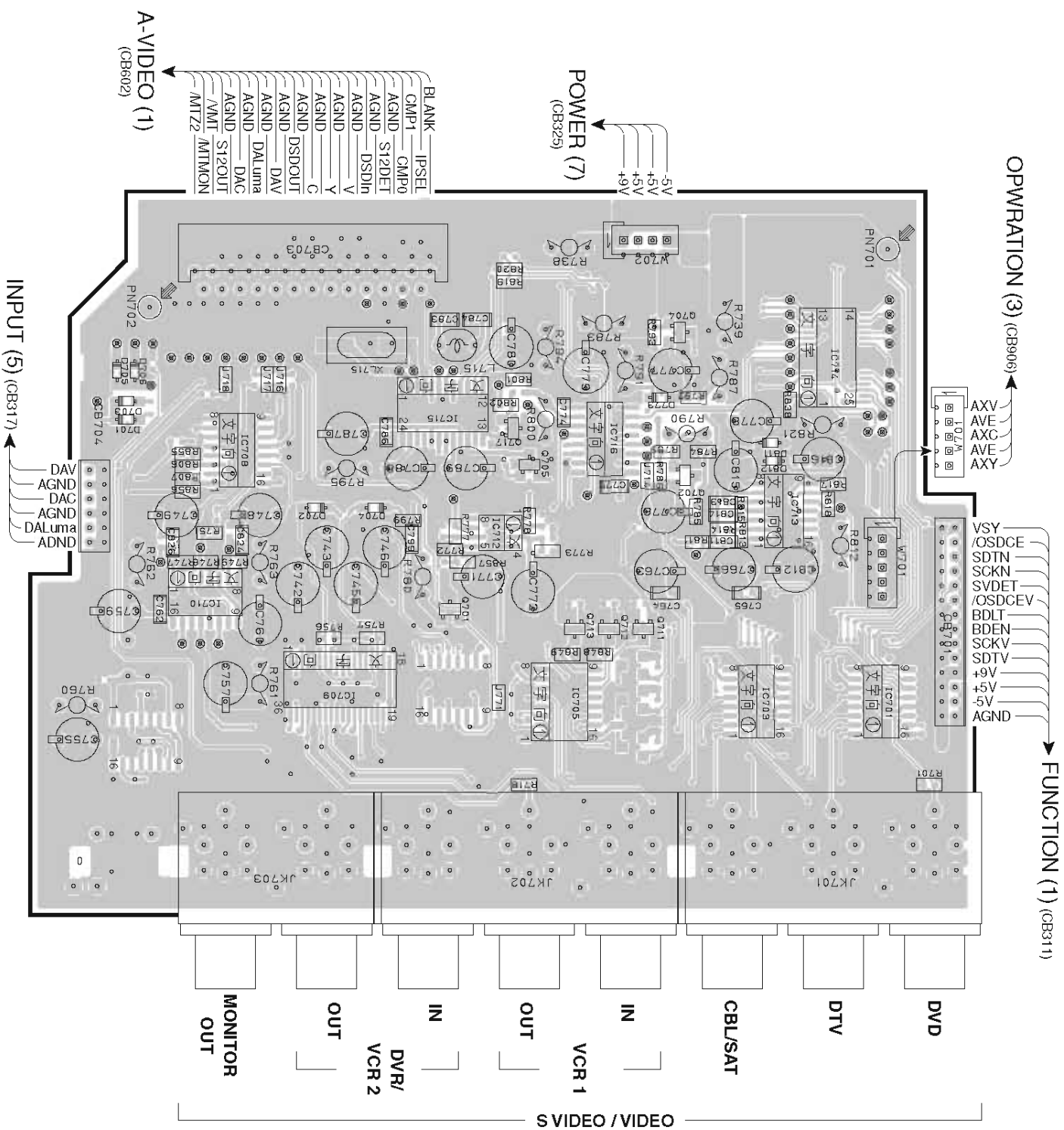

Ref.no.	Location
D701	C6
D702	C5
D703	B6
D704	C5
D705	B6
D706	B6
D707	G5
D708	G5
D771	G3
D772	G3
D773	B3
D774	G3
D775	-
D811	C3
D812	C3
IC701	D2
IC703	D3
IC705	D4
IC708	C5
IC709	D5
IC710	C5
IC712	C4
IC713	C3
IC714	B3
IC715	C4
IC716	C4
Q701	C4
Q702	C3
Q703	H3
Q704	B3
Q705	C4
Q706	G4
Q711	D3
Q712	D4
Q713	D4
Q717	C4

Circuit No.	U, C, J	R, K	T, A, B, G, L	S1/S2 Detection
C701-705	O	X	X	S1/S2 Detection
C781	O	O	X	NTSC or PAL
C782	O	O	X	NTSC or PAL
C785	O	O	X	NTSC or PAL
J701-705	X	O	O	Not S1/S2 Detection
JK701, 702	O	O	O	NI or Au
JK703	O	O	O	NI or Au
PJ701	O	O	O	NI or Au
XL715	O	O	O	NTSC or PAL

X : NOT USED
O : USED/APPLICABLE

PRINTED CIRCUIT BOARD

D-VIDEO P.C.B. (Side A) Lead Free Solder Used

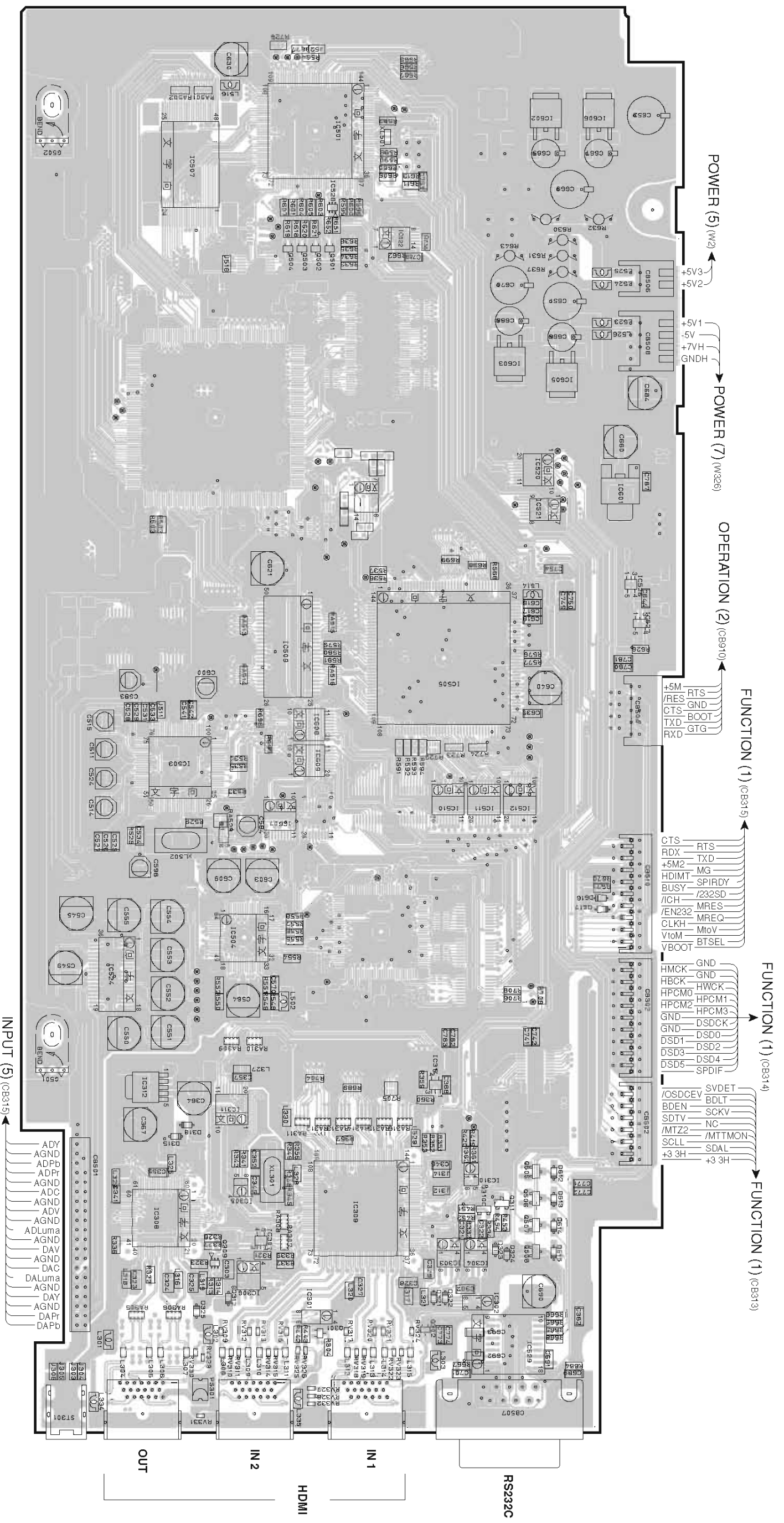

● Semiconductor Location

Ref.no.	Location	Ref.no.	Location	Ref.no.	Location	Ref.no.	Location	Ref.no.	Location	Ref.no.	Location	Ref.no.	Location	Ref.no.	Location	Ref.no.	Location
D312	I5	D324	I3	D616	F3	IC305	H5	IC311	H5	IC505	E4	IC520	D3	IC527	E3	IC605	B3
D315	H5	D325	I5	D617	G3	IC306	I5	IC312	H6	IC507	B5	IC521	D3	IC528	B4	IC606	B3
D318	H5	D612	H3	IC301	I4	IC307	I5	IC314	H4	IC509	E5	IC522	B4	IC529	I3	IC607	I5
D321	H5	D613	H3	IC302	I4	IC308	H5	IC305	B5	IC510	F4	IC524	G6	IC601	D3	IC608	E5
D322	I4	D614	H3	IC303	I4	IC309	H4	IC501	F5	IC511	F3	IC525	F5	IC602	B3	IC609	I5
D323	I3	D615	I3	IC304	I4	IC310	H4	IC504	G5	IC512	F3	IC526	E3	IC603	C3	Q301	I4
																Q502	B5
																Q302	I4
																Q503	B5
																Q504	B5
																Q505	H3
																Q310	H3
																Q311	H3
																Q506	H3
																Q507	H3

1 ■ PRINTED CIRCUIT BOARD

D-VIDEO P.C.B. (Side B) Lead Free Solder Used

• Semiconductor Location

Ref.no.	Location	Ref.no.	Location
D601	D2	D607	B3
D602	B3	D608	C3
D603	C3	D610	C3
D605	C3	D611	B2
D606	B2		

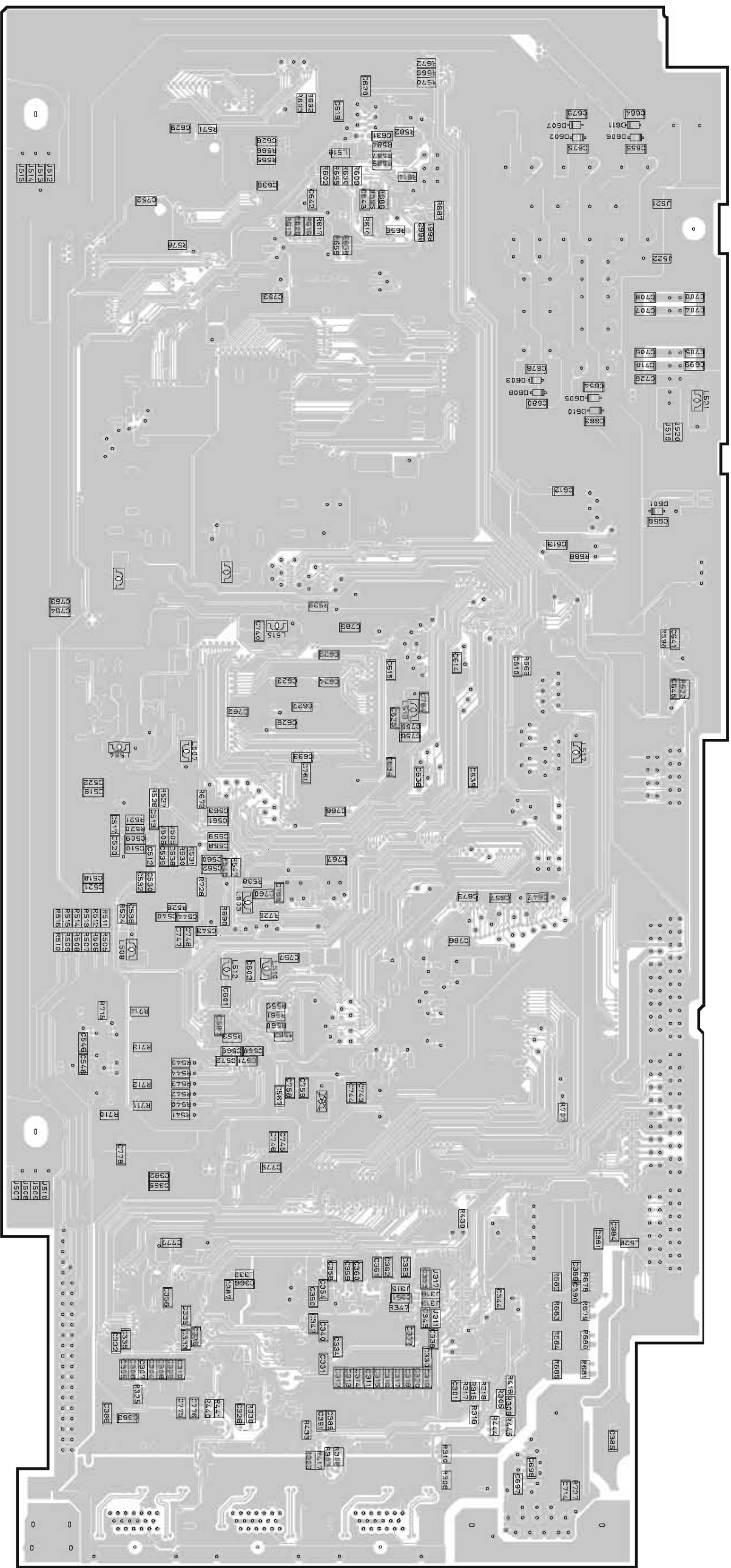

MEMO

A large, empty rectangular box with a double-line border, intended for handwritten notes.

MEMO

A second large, empty rectangular box with a double-line border, identical to the one above, intended for handwritten notes.

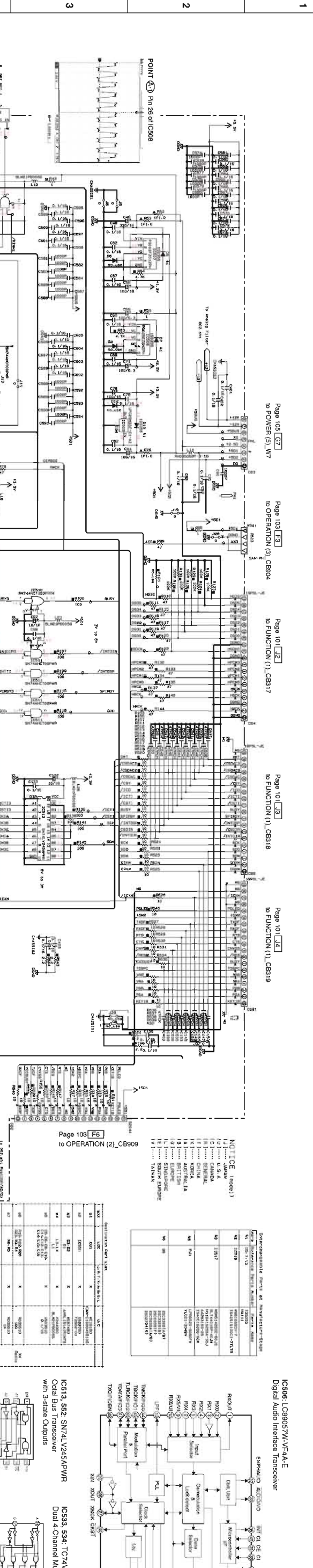

Page 105 [G7] to POWER (S)_W7

Page 103 [E3] to OPERATION (2)_CB904

Page 101 [J2] to FUNCTION (1)_CB817

Page 101 [J3] to FUNCTION (1)_CB818

Page 101 [J4] to FUNCTION (1)_CB919

Page 103 [F5] to OPERATION (2)_CB909

NOTICE (users)

REG. NO.	REG. NAME	REG. DATE	REG. TYPE
01	U.S.A.	1987.12.14	REGISTRATION
02	JAPAN	1988.03.15	REGISTRATION
03	EUROPE	1988.04.20	REGISTRATION
04	INDONESIA	1988.05.10	REGISTRATION
05	INDONESIA	1988.05.10	REGISTRATION
06	INDONESIA	1988.05.10	REGISTRATION
07	INDONESIA	1988.05.10	REGISTRATION
08	INDONESIA	1988.05.10	REGISTRATION
09	INDONESIA	1988.05.10	REGISTRATION
10	INDONESIA	1988.05.10	REGISTRATION
11	INDONESIA	1988.05.10	REGISTRATION
12	INDONESIA	1988.05.10	REGISTRATION
13	INDONESIA	1988.05.10	REGISTRATION
14	INDONESIA	1988.05.10	REGISTRATION
15	INDONESIA	1988.05.10	REGISTRATION
16	INDONESIA	1988.05.10	REGISTRATION
17	INDONESIA	1988.05.10	REGISTRATION
18	INDONESIA	1988.05.10	REGISTRATION
19	INDONESIA	1988.05.10	REGISTRATION
20	INDONESIA	1988.05.10	REGISTRATION
21	INDONESIA	1988.05.10	REGISTRATION
22	INDONESIA	1988.05.10	REGISTRATION
23	INDONESIA	1988.05.10	REGISTRATION
24	INDONESIA	1988.05.10	REGISTRATION
25	INDONESIA	1988.05.10	REGISTRATION
26	INDONESIA	1988.05.10	REGISTRATION
27	INDONESIA	1988.05.10	REGISTRATION
28	INDONESIA	1988.05.10	REGISTRATION
29	INDONESIA	1988.05.10	REGISTRATION
30	INDONESIA	1988.05.10	REGISTRATION
31	INDONESIA	1988.05.10	REGISTRATION
32	INDONESIA	1988.05.10	REGISTRATION
33	INDONESIA	1988.05.10	REGISTRATION
34	INDONESIA	1988.05.10	REGISTRATION
35	INDONESIA	1988.05.10	REGISTRATION
36	INDONESIA	1988.05.10	REGISTRATION
37	INDONESIA	1988.05.10	REGISTRATION
38	INDONESIA	1988.05.10	REGISTRATION
39	INDONESIA	1988.05.10	REGISTRATION
40	INDONESIA	1988.05.10	REGISTRATION
41	INDONESIA	1988.05.10	REGISTRATION
42	INDONESIA	1988.05.10	REGISTRATION
43	INDONESIA	1988.05.10	REGISTRATION
44	INDONESIA	1988.05.10	REGISTRATION
45	INDONESIA	1988.05.10	REGISTRATION
46	INDONESIA	1988.05.10	REGISTRATION
47	INDONESIA	1988.05.10	REGISTRATION
48	INDONESIA	1988.05.10	REGISTRATION
49	INDONESIA	1988.05.10	REGISTRATION
50	INDONESIA	1988.05.10	REGISTRATION

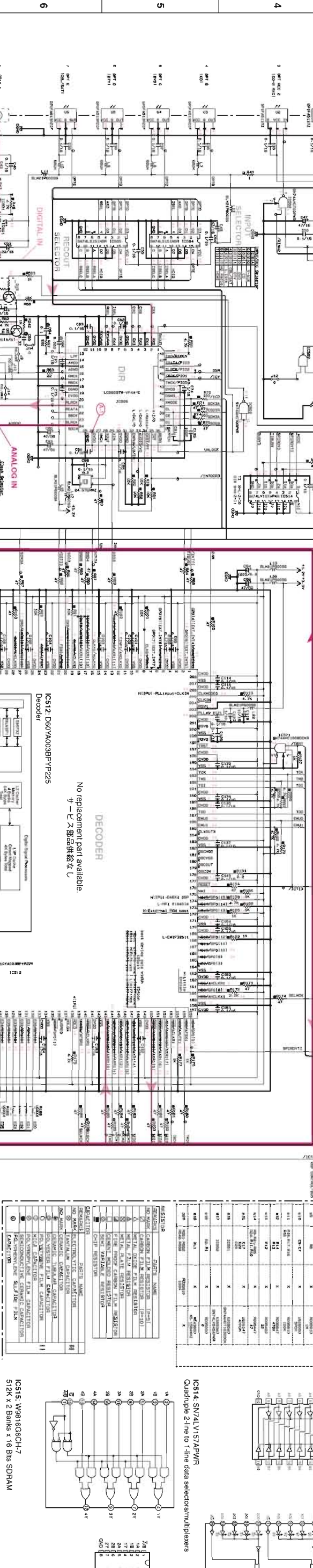

No replacement part available
サービスマニュアル

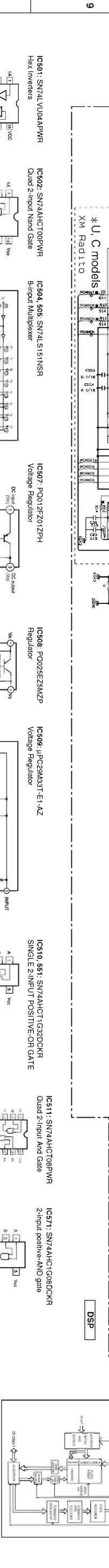
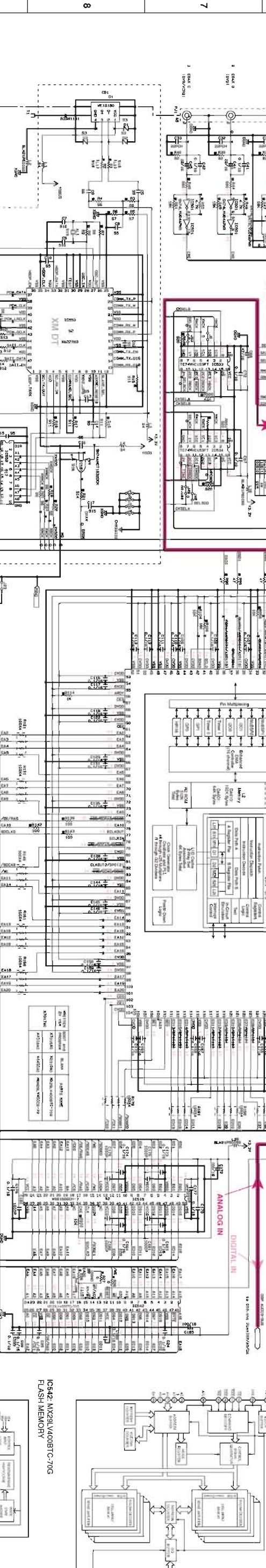

- IC501: SN74LV04APWR Hex Inverters
- IC502: SN74AHC00PWR Quad 2-input NAND Gate
- IC504: 505 SN74ALS15NSR 8-input Multiplexer
- IC507: PC012FZ01ZPH Voltage Regulator
- IC508: PC025E25VZP Regulator
- IC509: μPC29M33T-E1-AZ Voltage Regulator
- IC510: 551 SN74AHC1G32DCKR SINGLE 2-INPUT POSITIVE-OR GATE
- IC511: SN74AHC08PWR Quad 2-input AND Gate
- IC517: SN74AHC1G08DCKR 2-input positive-AND gate
- IC542: M3251A00B7C-70G FLASH MEMORY
- IC515: W9816GCH-7 512K x 2 Banks x 16 Bits SDRAM
- IC514: SN74LV157APWR Quad 2-line to 1-line data selectors/multiplexers
- IC513: 552 SN74LV245APWR Dual 4-Channel Multiplexer with 3-state Outputs
- IC533: 534: T074AHC159FT Dual 4-Channel Multiplexer
- IC506: LC89057M-VF4A-E Digital Audio Interface Transceiver

* All voltages are measured with a 10kΩV DC electronic volt meter.
 * Components having special characteristics are marked Δ, and must be replaced with parts having specifications equal to those originally installed.
 * Schematic diagram is subject to change without notice.

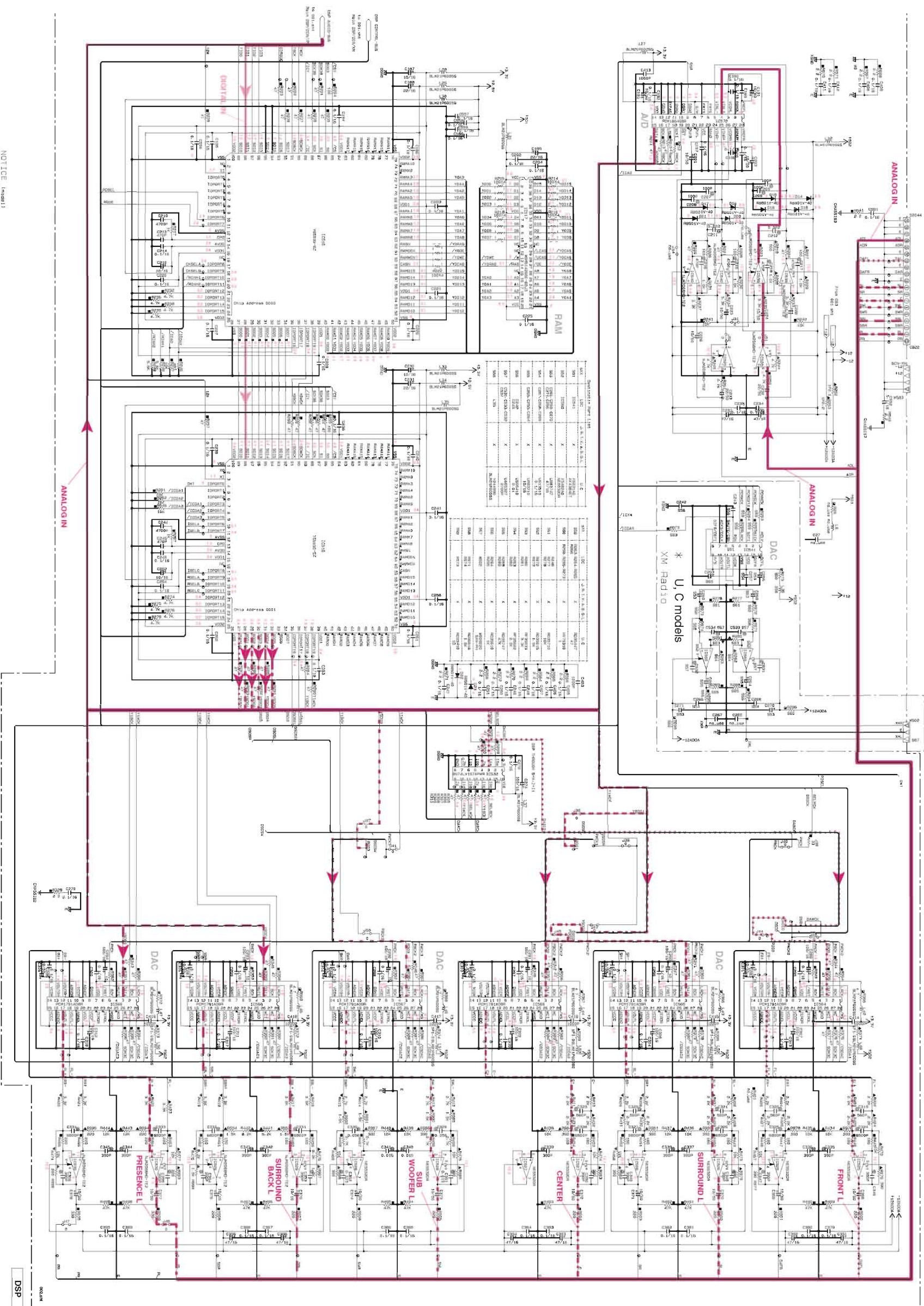

IC516 518 VSS930-SZ
 DSP

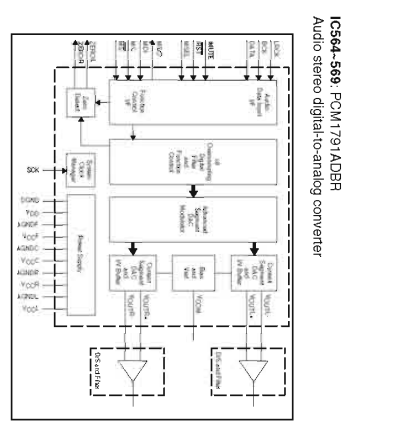
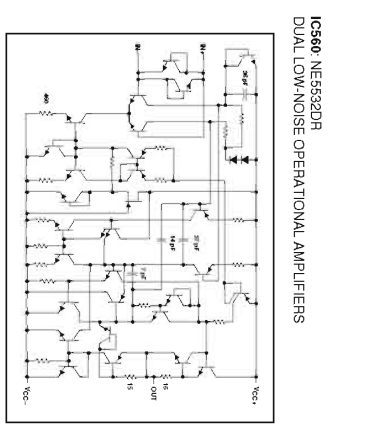
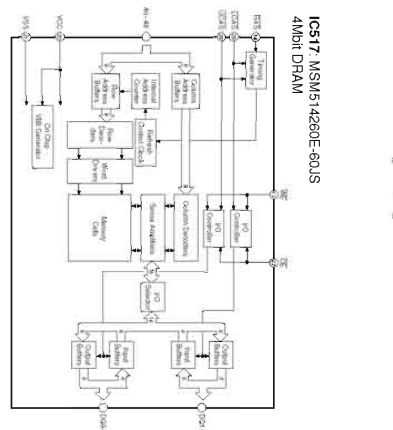
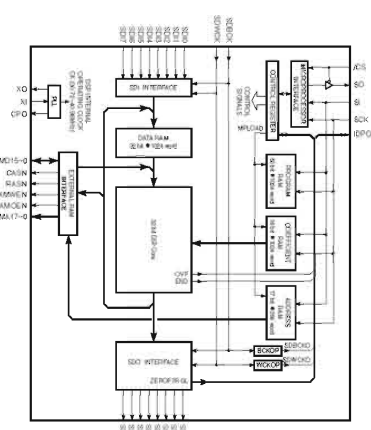

IC570 PCM1804DBR
 Stereo A/D converter

IC530 529, 530, 539, 540 NJM2068MDT-E2
 Dual OP-Amp

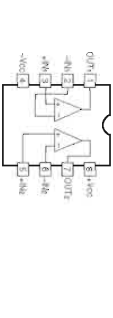

IC535-538 NE552DR
 Dual OP-Amp

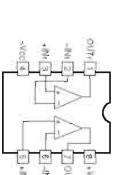

IC532 S174U157APMF
 Quaduple 2-line to 1-line data selector/multiplexers

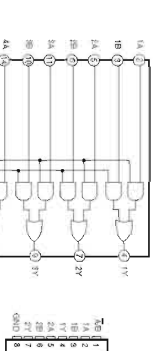

IC541 AK4394ET
 D/A Converter

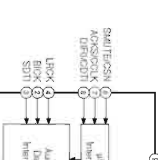

NOTICE (cont'd)

- (A) ... JAPAN
- (B) ... USA
- (C) ... GERMANY
- (D) ... CANADA
- (E) ... AUSTRALIA
- (F) ... CHINA
- (G) ... HONG KONG
- (H) ... SINGAPORE
- (I) ... SOUTH AFRICA
- (J) ... TAIWAN

* All voltages are measured with a 10MΩ/V DC electronic volt meter.
 * Components having special characteristics are marked Δ, and must be replaced with parts having specifications equal to those originally installed.
 * Schematic diagram is subject to change without notice.

● 電圧は、内部抵抗10MΩの電圧計で測定したものです。
 ● Δ印のある部品は、特殊性部品を併用する必要があります。部品の交換が必要な場合、パーツリストに記載されている部品を使用してください。
 ● 本回路図は変更される場合があります。品質のため予告なく変更することがあります。

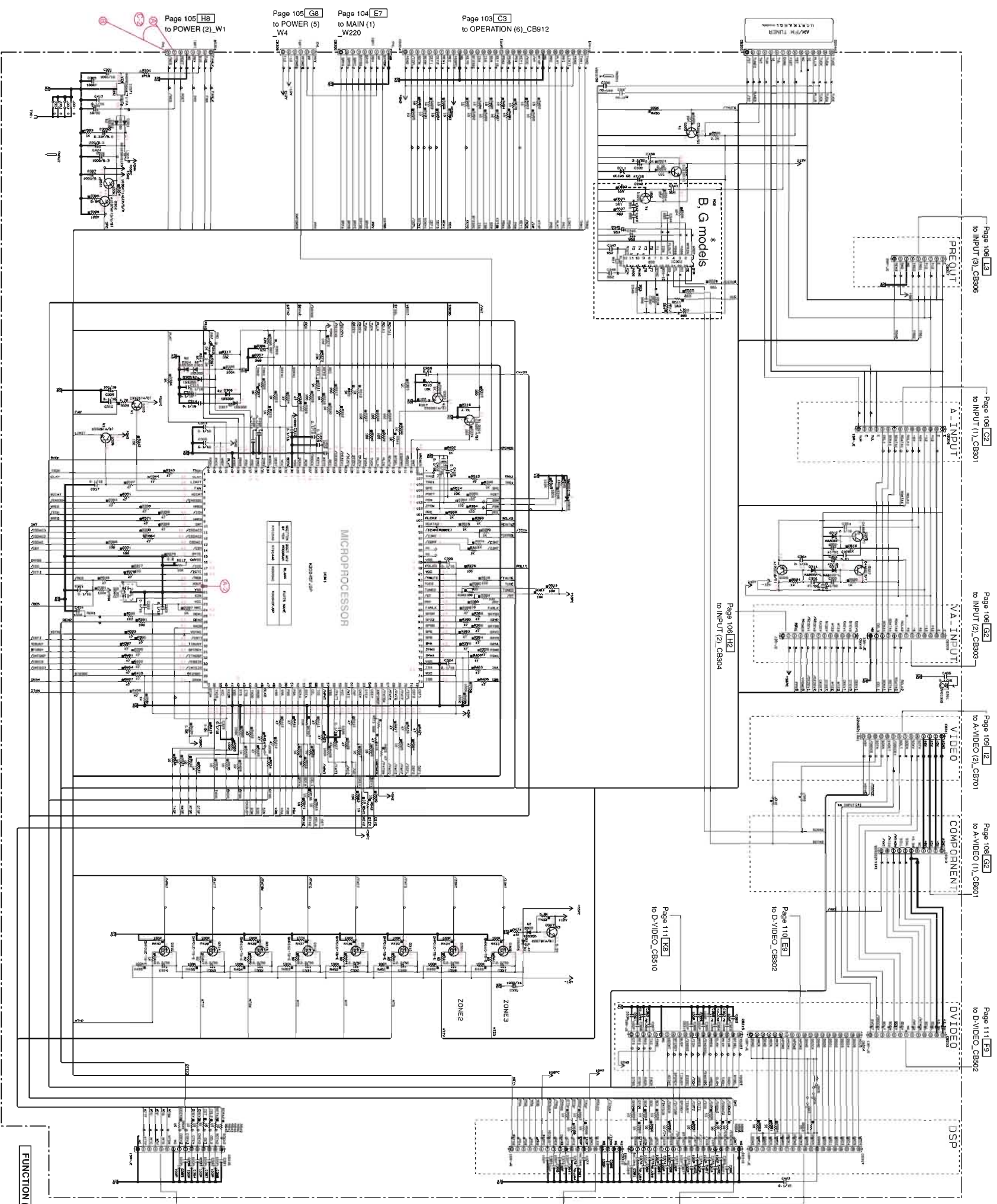

Pin No.	Symbol	Function	Notes
1
2
3
4
5
6
7
8
9
10
11
12
13
14
15
16
17
18
19
20
21
22
23
24
25
26
27
28
29
30
31
32
33
34
35
36
37
38
39
40
41
42
43
44
45
46
47
48
49
50
51
52
53
54
55
56
57
58
59
60
61
62
63
64
65
66
67
68
69
70
71
72
73
74
75
76
77
78
79
80
81
82
83
84
85
86
87
88
89
90
91
92
93
94
95
96
97
98
99
100

NOTICE

1. All voltages are measured with a 10kΩ/V DC electronic volt meter.
 2. Components having special characteristics are marked Δ, and must be replaced with parts having specifications equal to those originally installed.
 3. Schematic diagram is subject to change without notice.

IC302: LC72722PM
 RDS Signal Processor

IC571: RH8588A11-FA
 Voltage regulator

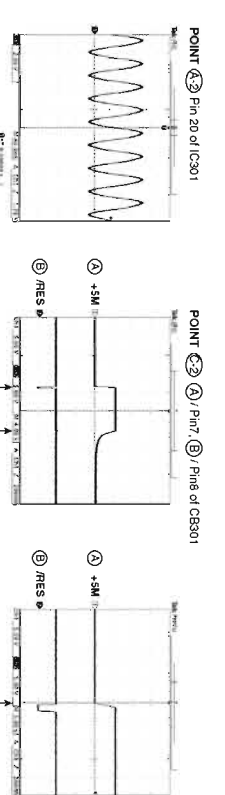

* All voltages are measured with a 10kΩ/V DC electronic volt meter.
 * Components having special characteristics are marked Δ, and must be replaced with parts having specifications equal to those originally installed.
 * Schematic diagram is subject to change without notice.

1 2 3 4 5 6 7 8 9 10 A B C D E F G H I J K L M N

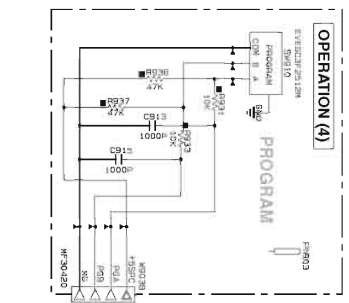
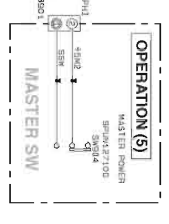
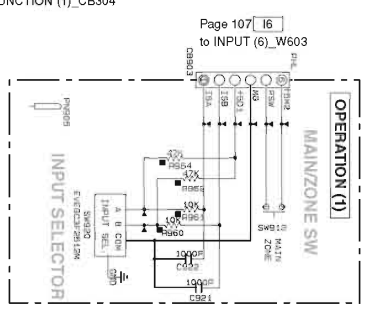
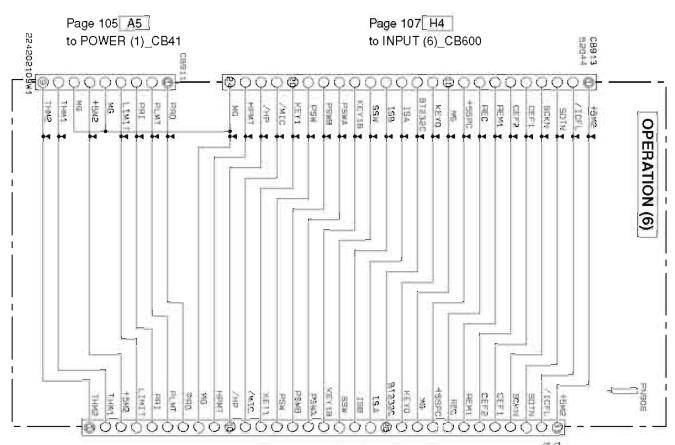

INTERCOMPONENT'S PARTS BY MANUFACTURER'S NAME

MARK	REFERENCE PARTS NUMBER	PARTS NAME	MANUFACTURER'S NAME
95	CR95-918	RESISTOR	DAIICHI ELECTRONIC INDUSTRIES

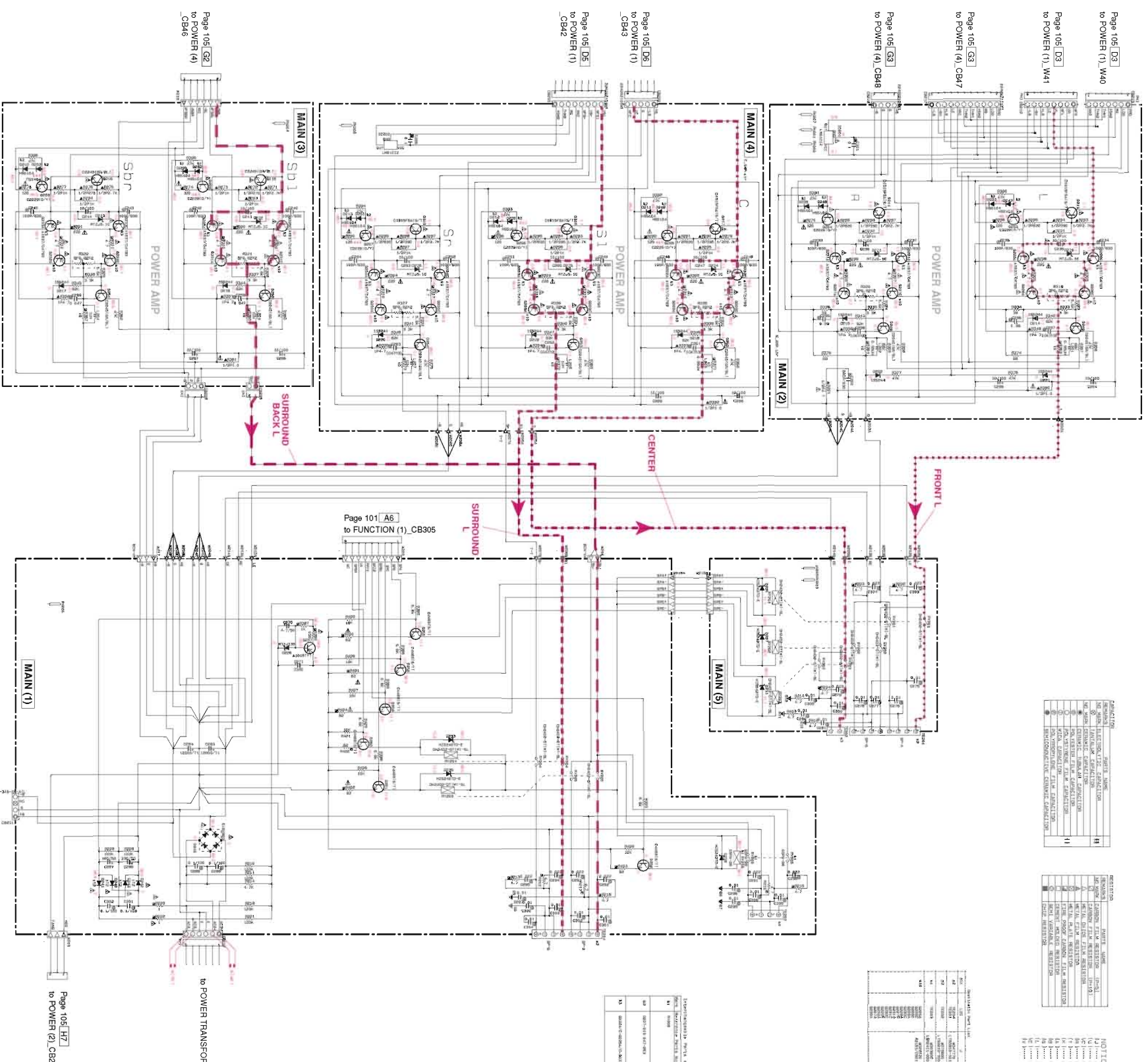

FUNCTION	PART NAME	REVISION
1	POWER AMP	1
2	SP1	1
3	SP2	1
4	SP3	1
5	FUNCTION (1)	1

SECTION	PART NAME	REVISION
1	POWER TRANSFORMER	1
2	POWER AMP	1
3	SP1	1
4	SP2	1
5	SP3	1
6	FUNCTION (1)	1

NOTICE (Main 1)
1. All voltages are measured with a 10MΩ/V DC electronic volt meter.
2. Components having special characteristics are marked Δ and must be replaced with parts having specifications equal to those originally installed.
3. Schematic diagram is subject to change without notice.

NO.	REVISION	DATE	REVISION	DATE	REVISION
1	1.00	2001.12.10	1.00	2001.12.10	1.00
2	1.01	2002.01.10	1.01	2002.01.10	1.01
3	1.02	2002.02.10	1.02	2002.02.10	1.02
4	1.03	2002.03.10	1.03	2002.03.10	1.03
5	1.04	2002.04.10	1.04	2002.04.10	1.04
6	1.05	2002.05.10	1.05	2002.05.10	1.05
7	1.06	2002.06.10	1.06	2002.06.10	1.06
8	1.07	2002.07.10	1.07	2002.07.10	1.07
9	1.08	2002.08.10	1.08	2002.08.10	1.08
10	1.09	2002.09.10	1.09	2002.09.10	1.09
11	1.10	2002.10.10	1.10	2002.10.10	1.10
12	1.11	2002.11.10	1.11	2002.11.10	1.11
13	1.12	2002.12.10	1.12	2002.12.10	1.12
14	1.13	2003.01.10	1.13	2003.01.10	1.13
15	1.14	2003.02.10	1.14	2003.02.10	1.14
16	1.15	2003.03.10	1.15	2003.03.10	1.15
17	1.16	2003.04.10	1.16	2003.04.10	1.16
18	1.17	2003.05.10	1.17	2003.05.10	1.17
19	1.18	2003.06.10	1.18	2003.06.10	1.18
20	1.19	2003.07.10	1.19	2003.07.10	1.19
21	1.20	2003.08.10	1.20	2003.08.10	1.20
22	1.21	2003.09.10	1.21	2003.09.10	1.21
23	1.22	2003.10.10	1.22	2003.10.10	1.22
24	1.23	2003.11.10	1.23	2003.11.10	1.23
25	1.24	2003.12.10	1.24	2003.12.10	1.24

NO.	REVISION	DATE	REVISION	DATE	REVISION
1	1.00	2001.12.10	1.00	2001.12.10	1.00
2	1.01	2002.01.10	1.01	2002.01.10	1.01
3	1.02	2002.02.10	1.02	2002.02.10	1.02
4	1.03	2002.03.10	1.03	2002.03.10	1.03
5	1.04	2002.04.10	1.04	2002.04.10	1.04
6	1.05	2002.05.10	1.05	2002.05.10	1.05
7	1.06	2002.06.10	1.06	2002.06.10	1.06
8	1.07	2002.07.10	1.07	2002.07.10	1.07
9	1.08	2002.08.10	1.08	2002.08.10	1.08
10	1.09	2002.09.10	1.09	2002.09.10	1.09
11	1.10	2002.10.10	1.10	2002.10.10	1.10
12	1.11	2002.11.10	1.11	2002.11.10	1.11
13	1.12	2002.12.10	1.12	2002.12.10	1.12
14	1.13	2003.01.10	1.13	2003.01.10	1.13
15	1.14	2003.02.10	1.14	2003.02.10	1.14
16	1.15	2003.03.10	1.15	2003.03.10	1.15
17	1.16	2003.04.10	1.16	2003.04.10	1.16
18	1.17	2003.05.10	1.17	2003.05.10	1.17
19	1.18	2003.06.10	1.18	2003.06.10	1.18
20	1.19	2003.07.10	1.19	2003.07.10	1.19
21	1.20	2003.08.10	1.20	2003.08.10	1.20
22	1.21	2003.09.10	1.21	2003.09.10	1.21
23	1.22	2003.10.10	1.22	2003.10.10	1.22
24	1.23	2003.11.10	1.23	2003.11.10	1.23
25	1.24	2003.12.10	1.24	2003.12.10	1.24

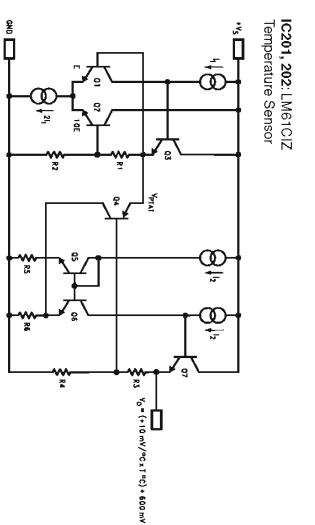

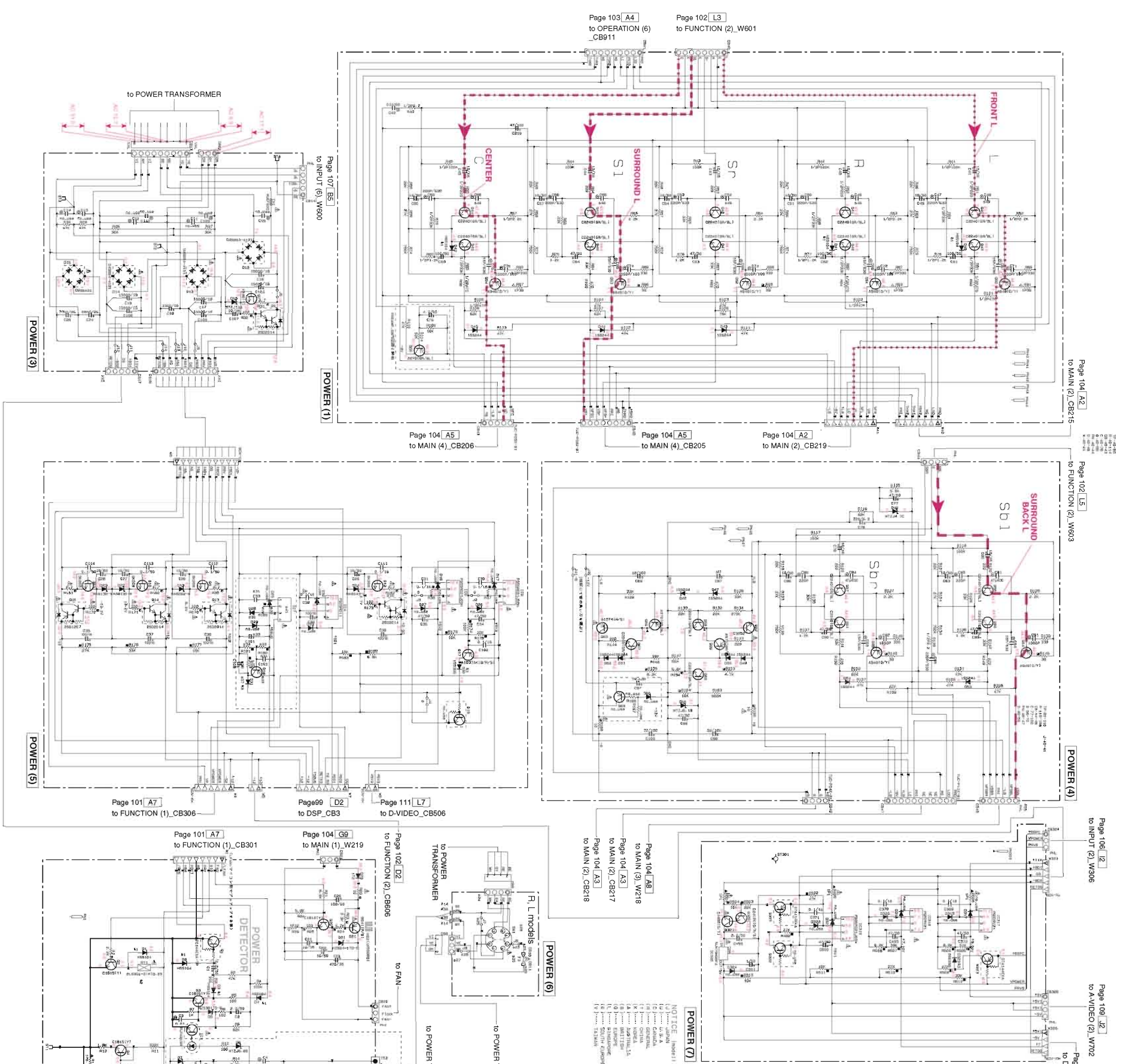

NOTICE (Model1)

RELATION	PARTS NAME	DEFINITION
1	RESISTOR	RESISTOR
2	CAPACITOR	CAPACITOR
3	DIODE	DIODE
4	TRANSISTOR	TRANSISTOR
5	IC	IC
6	RELAY	RELAY
7	INDUCTOR	INDUCTOR
8	OPTICAL COUPLER	OPTICAL COUPLER
9	RELAY	RELAY
10	RELAY	RELAY
11	RELAY	RELAY
12	RELAY	RELAY
13	RELAY	RELAY
14	RELAY	RELAY
15	RELAY	RELAY
16	RELAY	RELAY
17	RELAY	RELAY
18	RELAY	RELAY
19	RELAY	RELAY
20	RELAY	RELAY
21	RELAY	RELAY
22	RELAY	RELAY
23	RELAY	RELAY
24	RELAY	RELAY
25	RELAY	RELAY
26	RELAY	RELAY
27	RELAY	RELAY
28	RELAY	RELAY
29	RELAY	RELAY
30	RELAY	RELAY
31	RELAY	RELAY
32	RELAY	RELAY
33	RELAY	RELAY
34	RELAY	RELAY
35	RELAY	RELAY
36	RELAY	RELAY
37	RELAY	RELAY
38	RELAY	RELAY
39	RELAY	RELAY
40	RELAY	RELAY
41	RELAY	RELAY
42	RELAY	RELAY
43	RELAY	RELAY
44	RELAY	RELAY
45	RELAY	RELAY
46	RELAY	RELAY
47	RELAY	RELAY
48	RELAY	RELAY
49	RELAY	RELAY
50	RELAY	RELAY
51	RELAY	RELAY
52	RELAY	RELAY
53	RELAY	RELAY
54	RELAY	RELAY
55	RELAY	RELAY
56	RELAY	RELAY
57	RELAY	RELAY
58	RELAY	RELAY
59	RELAY	RELAY
60	RELAY	RELAY
61	RELAY	RELAY
62	RELAY	RELAY
63	RELAY	RELAY
64	RELAY	RELAY
65	RELAY	RELAY
66	RELAY	RELAY
67	RELAY	RELAY
68	RELAY	RELAY
69	RELAY	RELAY
70	RELAY	RELAY
71	RELAY	RELAY
72	RELAY	RELAY
73	RELAY	RELAY
74	RELAY	RELAY
75	RELAY	RELAY
76	RELAY	RELAY
77	RELAY	RELAY
78	RELAY	RELAY
79	RELAY	RELAY
80	RELAY	RELAY
81	RELAY	RELAY
82	RELAY	RELAY
83	RELAY	RELAY
84	RELAY	RELAY
85	RELAY	RELAY
86	RELAY	RELAY
87	RELAY	RELAY
88	RELAY	RELAY
89	RELAY	RELAY
90	RELAY	RELAY
91	RELAY	RELAY
92	RELAY	RELAY
93	RELAY	RELAY
94	RELAY	RELAY
95	RELAY	RELAY
96	RELAY	RELAY
97	RELAY	RELAY
98	RELAY	RELAY
99	RELAY	RELAY
100	RELAY	RELAY

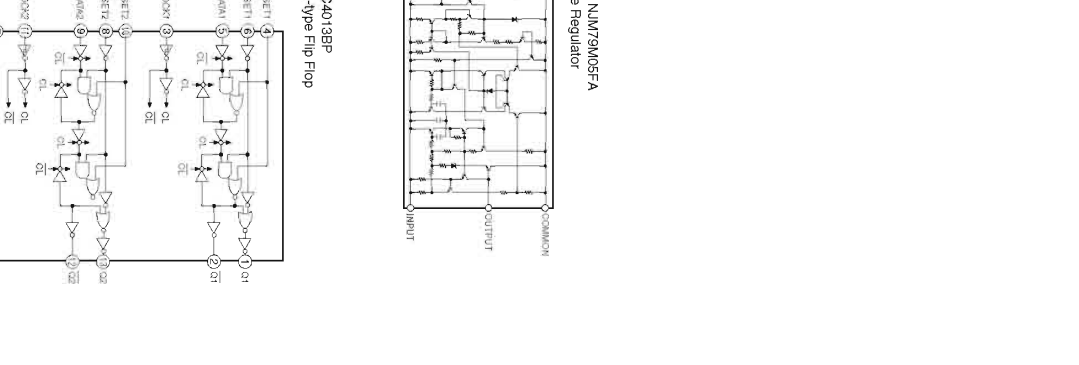
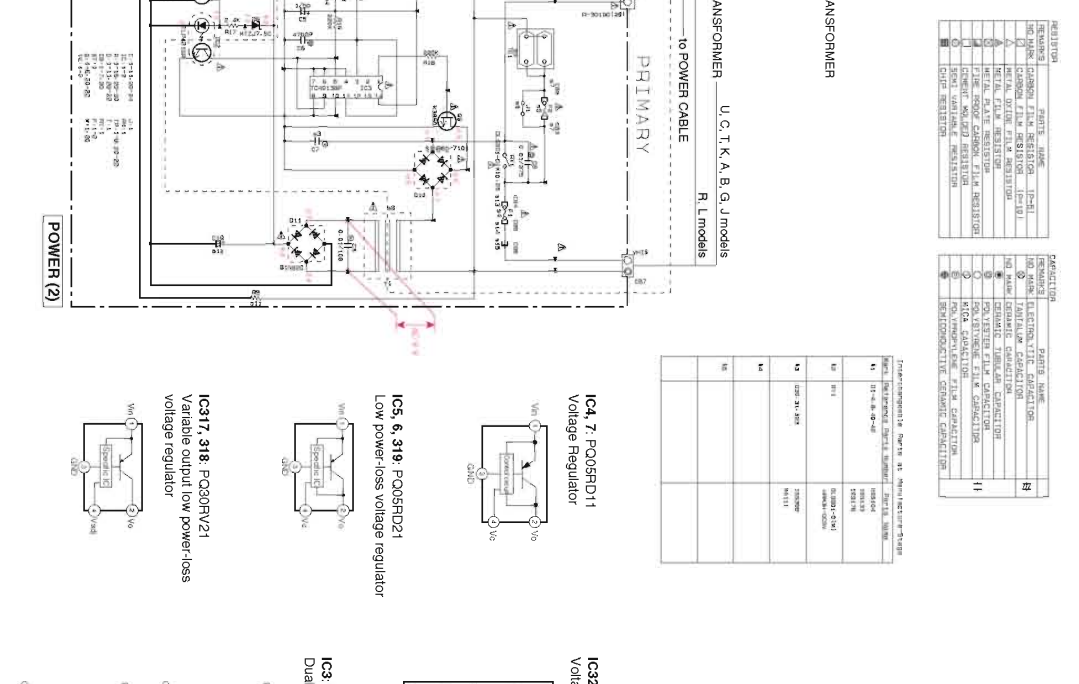

●電圧は、内部抵抗10MΩの電圧計で測定したものです。
 ●△印のある部品は、安全性能部品を示しています。部品の交換が必要な場合、
 △マークのある部品に同等品を使用してください。
 ●本図は、安全性能部品を示しています。部品の交換が必要な場合、
 △マークのある部品に同等品を使用してください。
 ●本図は、安全性能部品を示しています。部品の交換が必要な場合、
 △マークのある部品に同等品を使用してください。

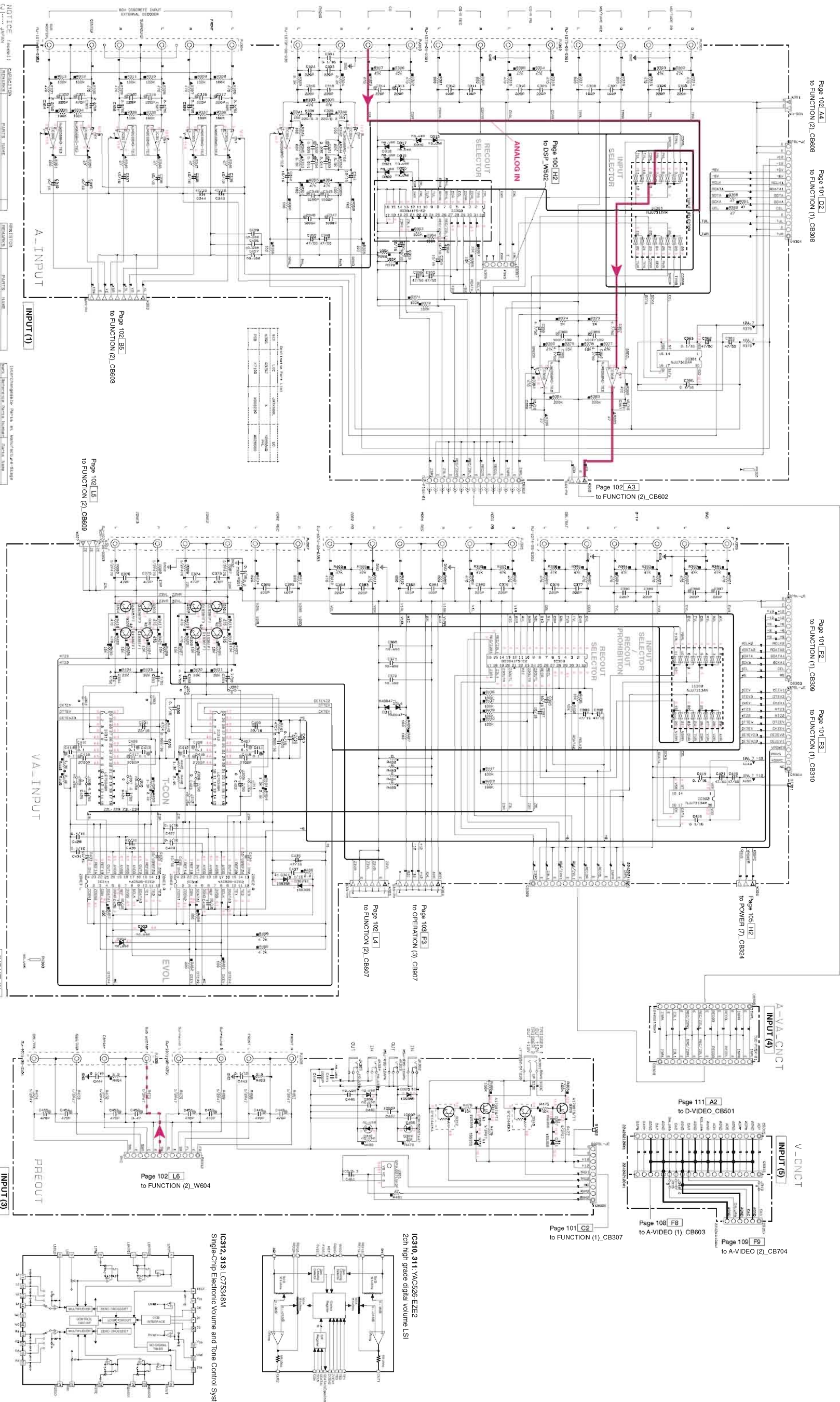

NOTICE (Page 1)

FUNCTION	TEST POINT
U	U.S.A.
C	CANADA
R	REST OF THE WORLD
NO MARK	NO MARK
K	KOREA
A	ASIA
S	SOUTH AFRICA
E	EUROPE
T	TAIWAN

RESISTOR	VALUE
1	100Ω
10	1kΩ
100	10kΩ
1000	100kΩ
10000	1MΩ
100000	10MΩ
1000000	100MΩ
10000000	1GΩ

CONDENSATOR	VALUE
1	100pF
10	1nF
100	10nF
1000	100nF
10000	1μF
100000	10μF
1000000	100μF
10000000	1000μF
100000000	10000μF

IC301: NJU7912AM Analog function switch

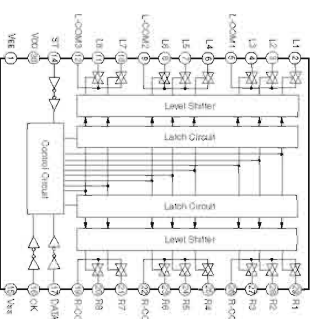

IC302: NJU7913AM Analog function switch

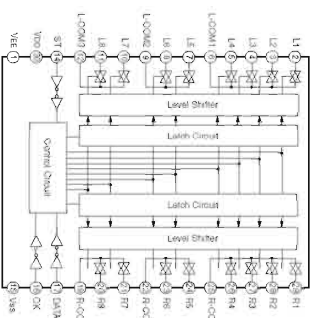

IC303: BD3841FS Function Switch

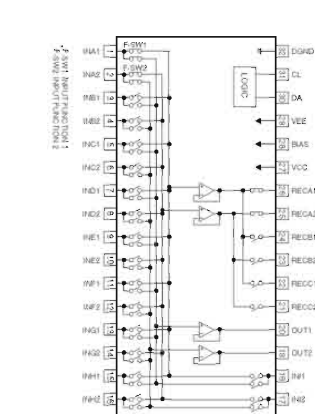

IC304: 308 NJM2068MD-TE2 Dual Op-Amp

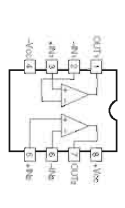

IC312: 313 LCT334M Single-Chip Electronic Volume and Tone Control System

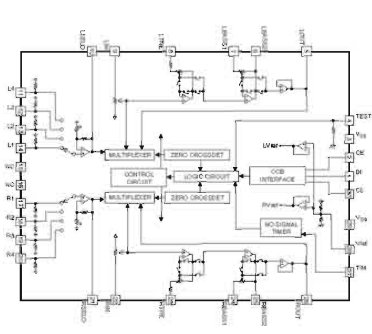

IC310, 311: VAS26-EZE2 2ch high grade digital volume LSI

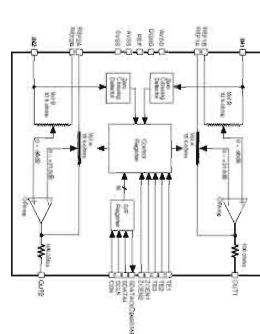

* All voltages are measured with a 10MΩV DC electronic voltmeter. * Components having special characteristics are marked Δ and must be replaced with parts having specifications equal to those originally installed. * Schematic diagram is subject to change without notice.

●電圧は、内部抵抗10MΩの電圧計で測定したものです。 ●Δ印のある部品は、特殊性を有する部品であり、必ず同等の部品を交換してください。 ●本図は、仕様変更を伴う場合があります。

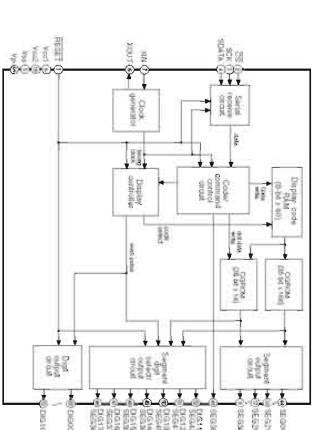
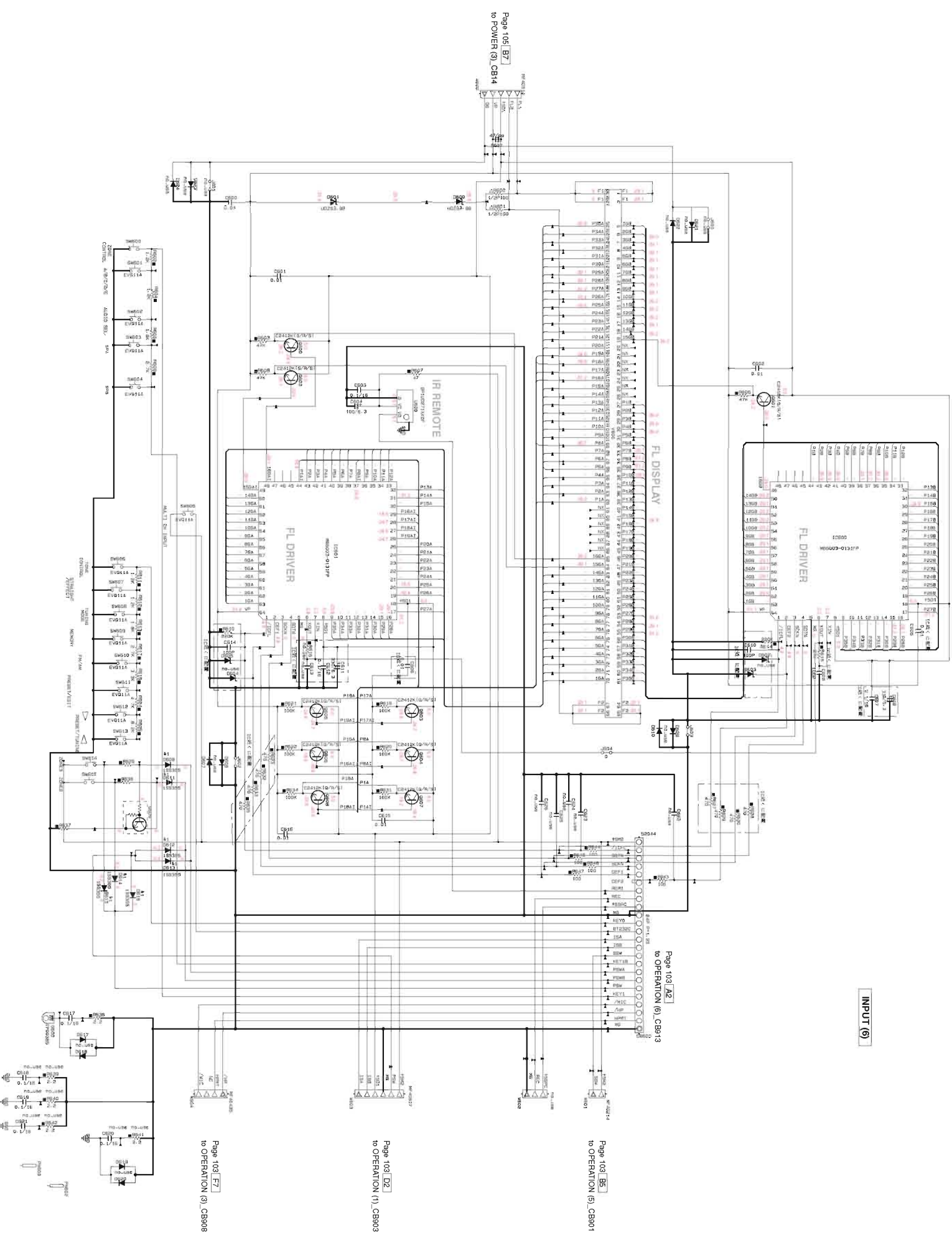

IC660_601_M6603-013FP
FL Display Driver

* All voltages are measured with a 10M Ω /V DC electronic volt meter.
 * Components having special characteristics are marked Δ and must be replaced with parts having specifications equal to those originally installed.
 * Schematic diagram is subject to change without notice.

●電圧は、内阻抵抗10M Ω の電圧計で測定したものです。
 ● Δ 印のある部品は、安全性能部品を示しています。部品の交換が必要な場合、
 パーツリストに照準を当てて同等品を使用してください。
 ●本回路図は標準回路図です。改良のため予告なく変更することがあります。

A B C D E F G H I J K L M N

1 2 3 4 5 6 7 8 9 10

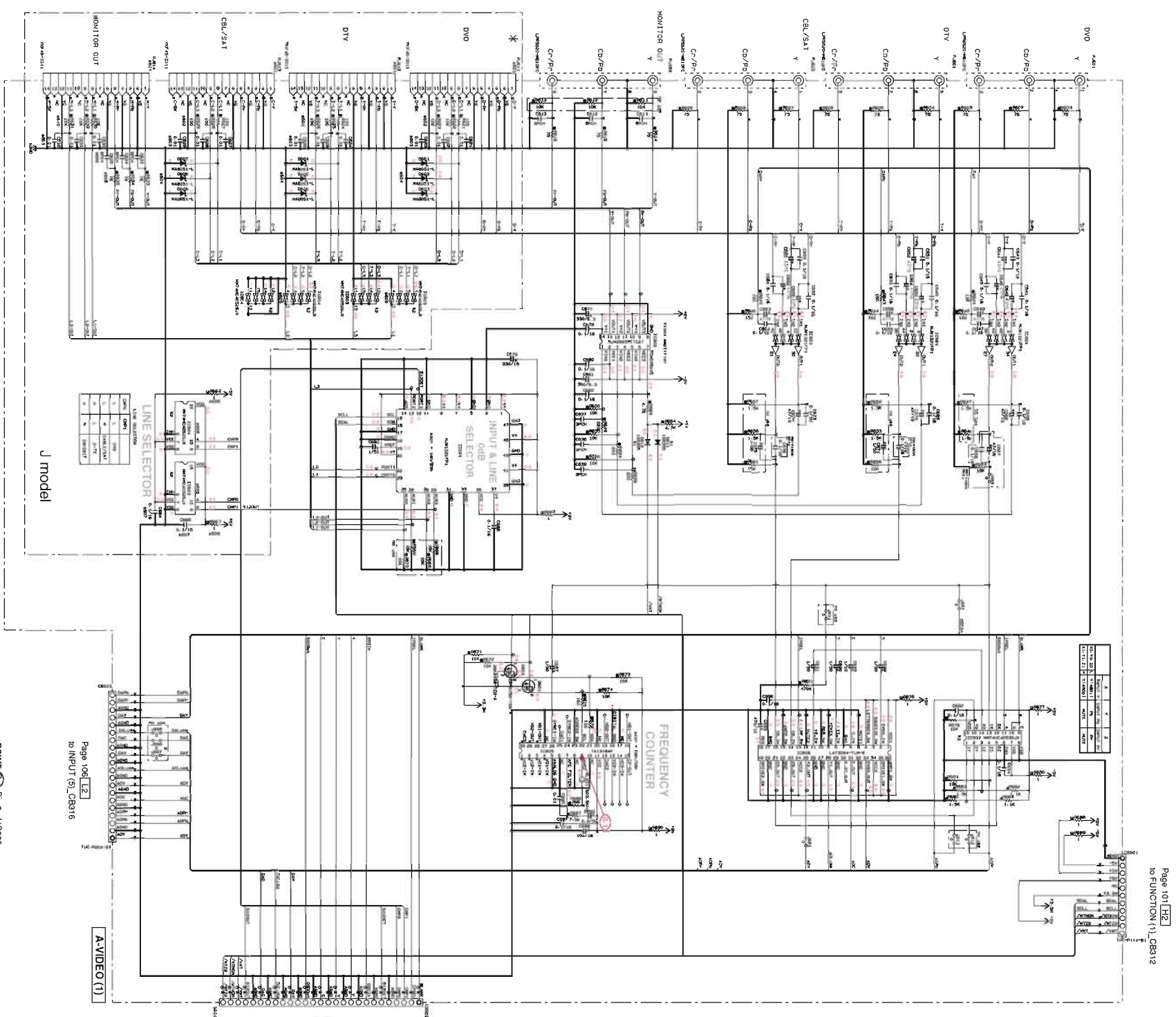

Page 101 [E2]
 to FUNCTION (1)_CB312

NOTICE (Important)

1) U.S.A.
 2) CANADA
 3) CHINA
 4) SOUTH KOREA
 5) THAILAND

MARKING	MARK	MARK	MARK	MARK	
1	U.S.A.	2	CANADA	3	CHINA
4	SOUTH KOREA	5	THAILAND	6	OTHER

FUNCTIONS

FUNCTION	MARK	MARK	MARK	MARK	
1	U.S.A.	2	CANADA	3	CHINA
4	SOUTH KOREA	5	THAILAND	6	OTHER

MARK	MARK	MARK	MARK	MARK	
1	U.S.A.	2	CANADA	3	CHINA
4	SOUTH KOREA	5	THAILAND	6	OTHER

Page 109 [G3]
 to A-VIDEO (2)_CB703

MARK	MARK	MARK	MARK	MARK	
1	U.S.A.	2	CANADA	3	CHINA
4	SOUTH KOREA	5	THAILAND	6	OTHER

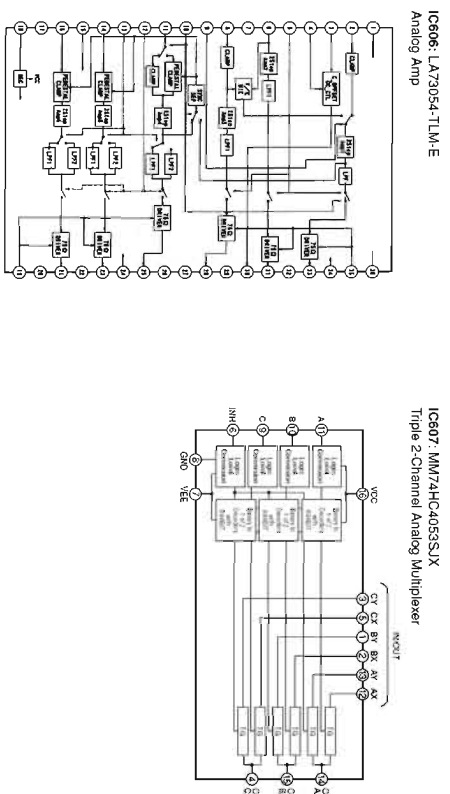
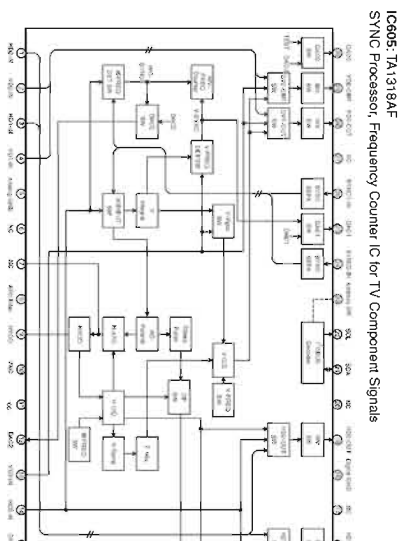
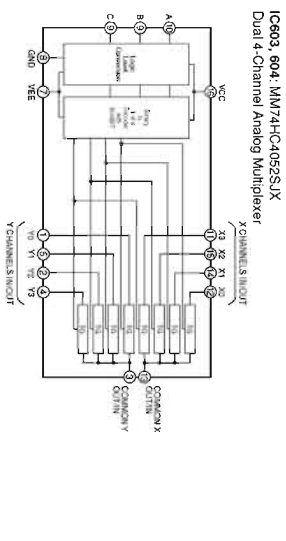
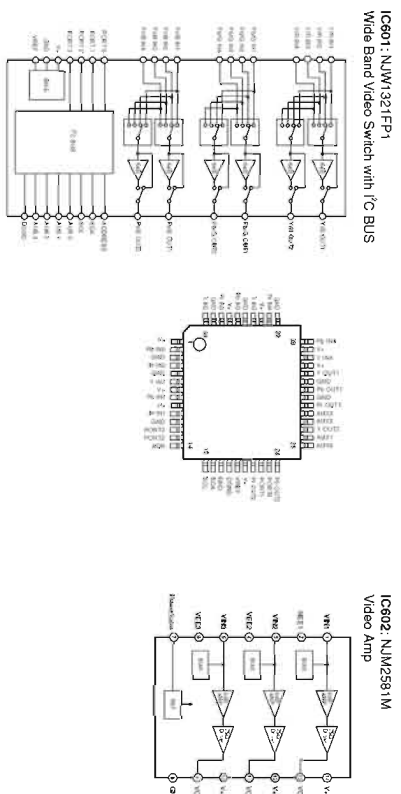
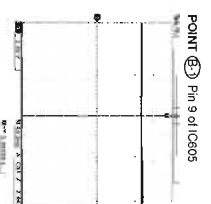

* All voltages are measured with a 10MΩV DC electronic voltmeter.
 * Components having special characteristics are marked Δ, and must be replaced with parts having specifications equal to those originally installed.
 * Schematic diagram is subject to change without notice.

● 電圧は、内部抵抗10MΩの電圧計で測定したものです。
 ● Δ印のある部品は、特殊性部品を示しています。部品の交換が必要な場合、パーツリストに記載されている部品を使用してください。
 ● 本図面は資料用図面です。改良のため予告なく変更することがあります。

Page 104 [E1]
to OPERATION (9)_CB906

Page 101 [E2]
to FUNCTION (1)_CB911

Page 105 [E2]
to POWER (7)_CB325

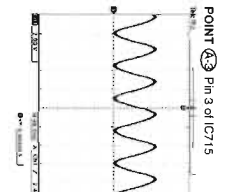
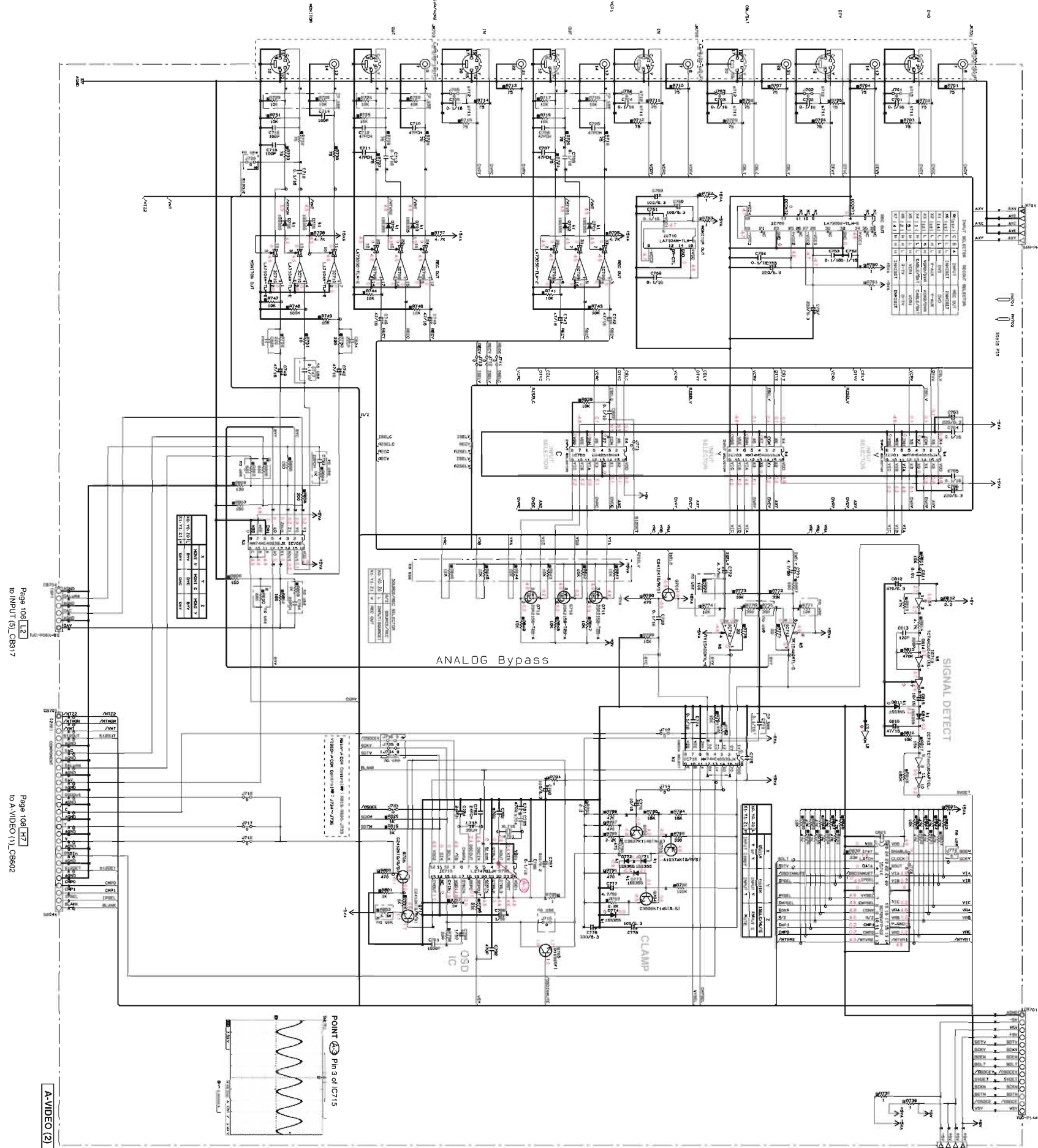

A-VIDEO (2)

NOTICE (Inches)

(J)..... JAPAN
(K)..... KOREA
(L)..... CANADA
(M)..... CHINA
(N)..... HONG KONG
(O)..... AUSTRALIA
(P)..... BERMUDA
(Q)..... SINGAPORE
(R)..... TAIWAN
(S)..... THAILAND
(T)..... SOUTH AFRICA
(U)..... SOUTH KOREA
(V)..... MALAYSIA
(W)..... PHILIPPINES
(X)..... INDIA
(Y)..... INDONESIA
(Z)..... MALAYSIA

RESISTORS

SYMBOL	VALUE	NAME
R1	10K	RESISTOR
R2	10K	RESISTOR
R3	10K	RESISTOR
R4	10K	RESISTOR
R5	10K	RESISTOR
R6	10K	RESISTOR
R7	10K	RESISTOR
R8	10K	RESISTOR
R9	10K	RESISTOR
R10	10K	RESISTOR
R11	10K	RESISTOR
R12	10K	RESISTOR
R13	10K	RESISTOR
R14	10K	RESISTOR
R15	10K	RESISTOR
R16	10K	RESISTOR
R17	10K	RESISTOR
R18	10K	RESISTOR
R19	10K	RESISTOR
R20	10K	RESISTOR
R21	10K	RESISTOR
R22	10K	RESISTOR
R23	10K	RESISTOR
R24	10K	RESISTOR
R25	10K	RESISTOR
R26	10K	RESISTOR
R27	10K	RESISTOR
R28	10K	RESISTOR
R29	10K	RESISTOR
R30	10K	RESISTOR
R31	10K	RESISTOR
R32	10K	RESISTOR
R33	10K	RESISTOR
R34	10K	RESISTOR
R35	10K	RESISTOR
R36	10K	RESISTOR
R37	10K	RESISTOR
R38	10K	RESISTOR
R39	10K	RESISTOR
R40	10K	RESISTOR
R41	10K	RESISTOR
R42	10K	RESISTOR
R43	10K	RESISTOR
R44	10K	RESISTOR
R45	10K	RESISTOR
R46	10K	RESISTOR
R47	10K	RESISTOR
R48	10K	RESISTOR
R49	10K	RESISTOR
R50	10K	RESISTOR
R51	10K	RESISTOR
R52	10K	RESISTOR
R53	10K	RESISTOR
R54	10K	RESISTOR
R55	10K	RESISTOR
R56	10K	RESISTOR
R57	10K	RESISTOR
R58	10K	RESISTOR
R59	10K	RESISTOR
R60	10K	RESISTOR
R61	10K	RESISTOR
R62	10K	RESISTOR
R63	10K	RESISTOR
R64	10K	RESISTOR
R65	10K	RESISTOR
R66	10K	RESISTOR
R67	10K	RESISTOR
R68	10K	RESISTOR
R69	10K	RESISTOR
R70	10K	RESISTOR
R71	10K	RESISTOR
R72	10K	RESISTOR
R73	10K	RESISTOR
R74	10K	RESISTOR
R75	10K	RESISTOR
R76	10K	RESISTOR
R77	10K	RESISTOR
R78	10K	RESISTOR
R79	10K	RESISTOR
R80	10K	RESISTOR
R81	10K	RESISTOR
R82	10K	RESISTOR
R83	10K	RESISTOR
R84	10K	RESISTOR
R85	10K	RESISTOR
R86	10K	RESISTOR
R87	10K	RESISTOR
R88	10K	RESISTOR
R89	10K	RESISTOR
R90	10K	RESISTOR
R91	10K	RESISTOR
R92	10K	RESISTOR
R93	10K	RESISTOR
R94	10K	RESISTOR
R95	10K	RESISTOR
R96	10K	RESISTOR
R97	10K	RESISTOR
R98	10K	RESISTOR
R99	10K	RESISTOR
R100	10K	RESISTOR

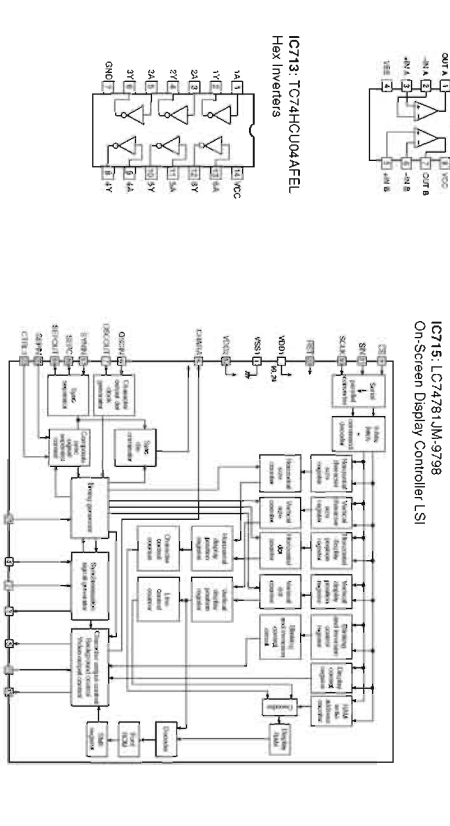
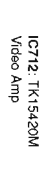
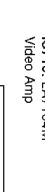
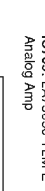

* All voltages are measured with a 10KΩV DC electronic volt meter.
* Components having special characteristics are marked Δ, and must be replaced with parts having specifications equal to those originally installed.
* Schematic diagram is subject to change without notice.

●電圧は、内部抵抗10KΩの電圧計で測定したものです。
●Δ印のある部品は、特殊性のある部品を示しています。部品の交換が必要となる場合は、同等の特性を持つ部品に交換してください。
●本回路図は仕様変更の可能性があります。

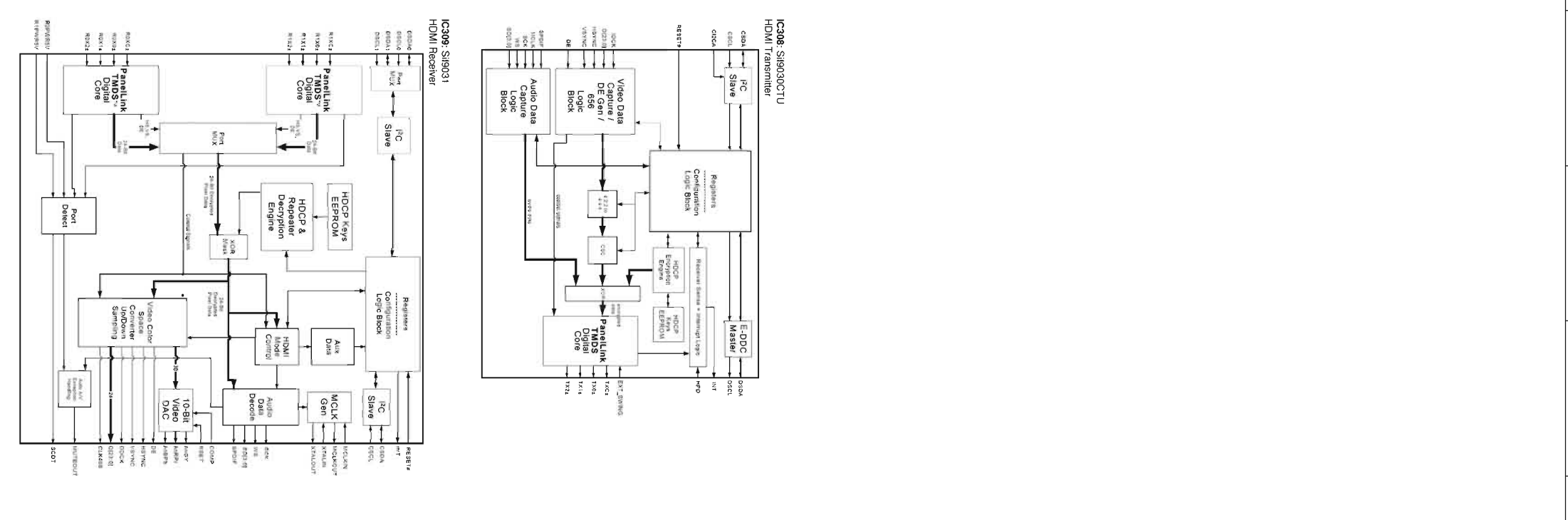
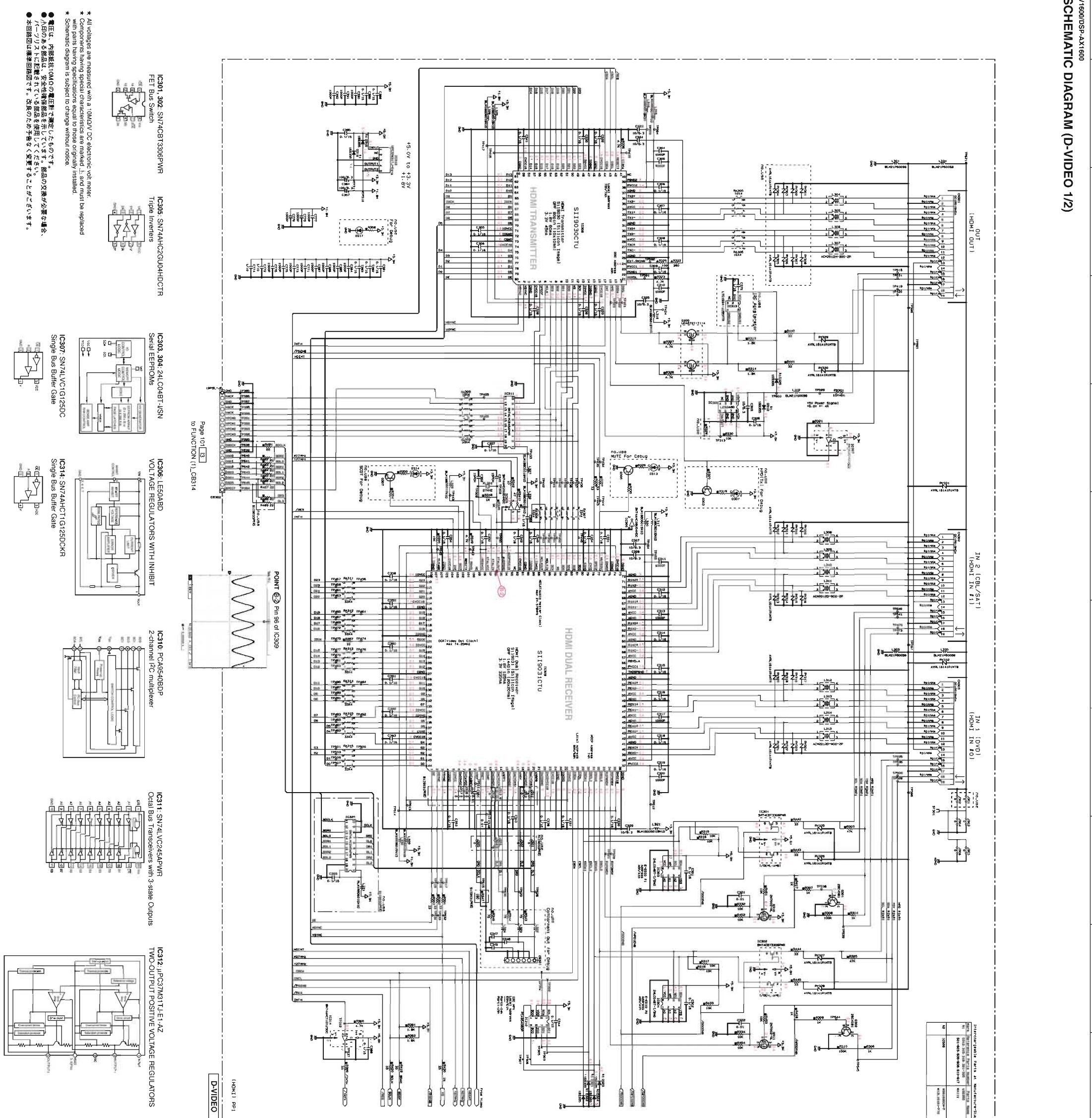

TRANSMITTER PARTS BY MANUFACTURE:SIEMENS
 IC307: SN74VLC1G125DC
 IC308: SI9031
 IC309: SI9030CTU
 IC310: PCA9548BP
 IC311: SN74VLC245APWR
 IC312: JPC37M1TLE1-AZ
 IC313: PCA9548BP
 IC314: SN74VLC1G125DCKR
 IC315: PCA9548BP

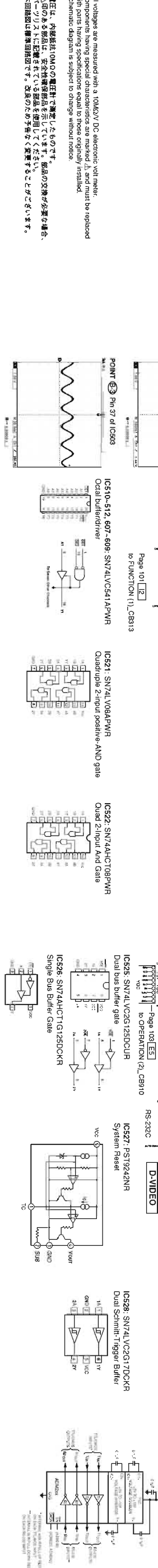
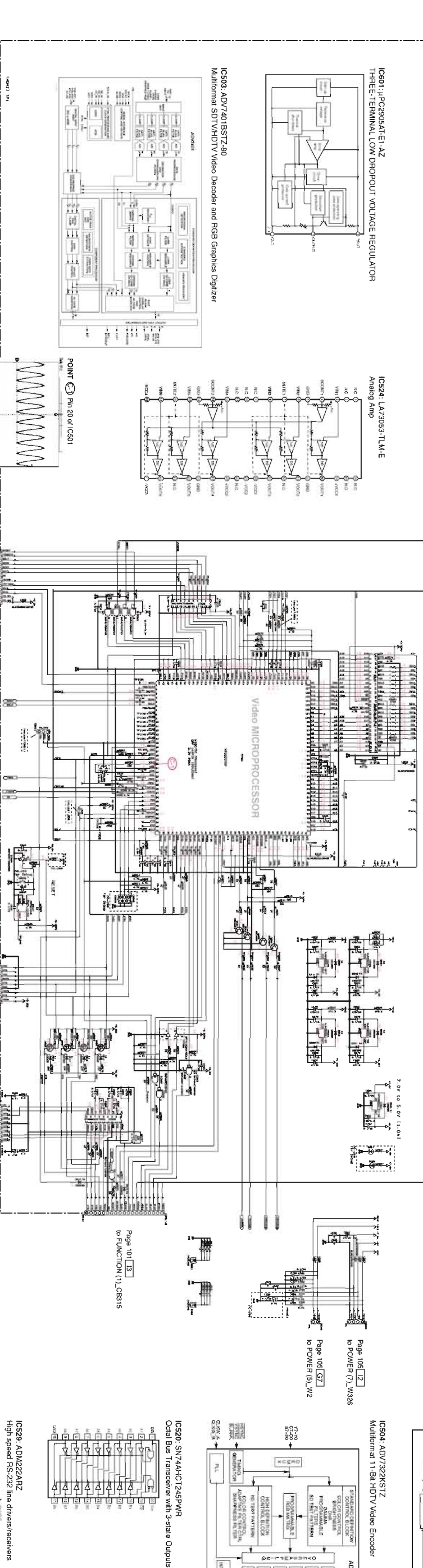
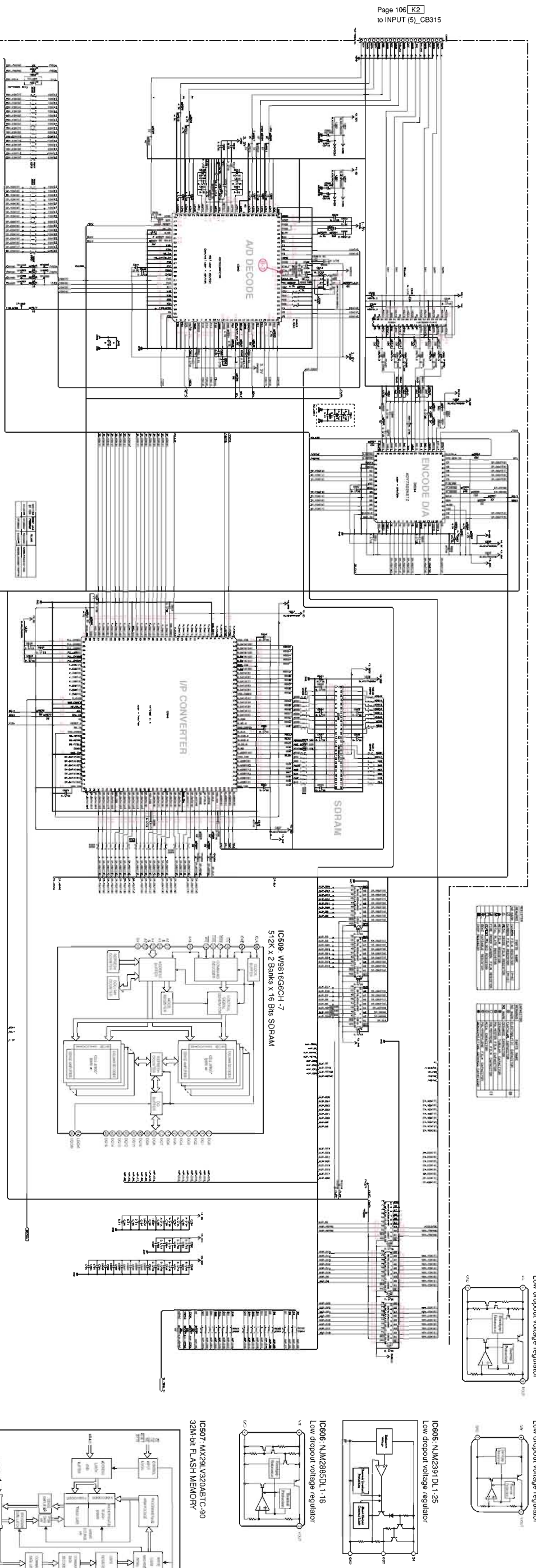

Page 106 [K2] to INPUT (5)_CB315

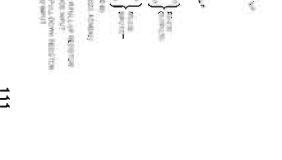
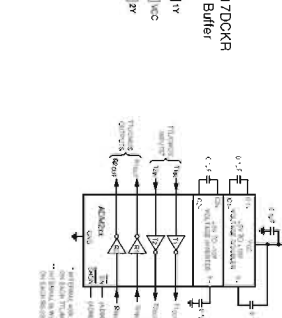
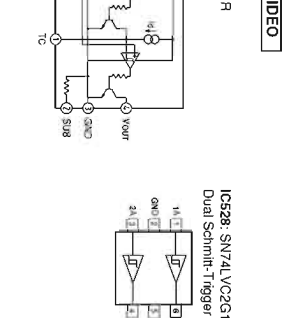
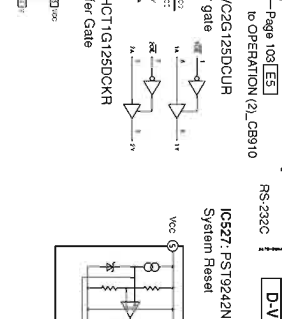
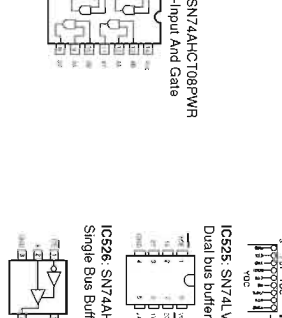
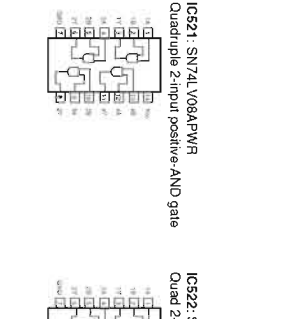
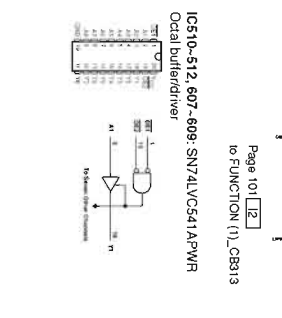
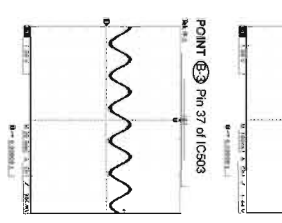

PARTS LIST

■ ELECTRICAL PARTS

■ WARNING

● Components having special characteristics are marked \triangle and must be replaced with parts having specifications equal to those originally installed.

● \triangle 印のある部分は、安全確保部品を示しています。部品の交換が必要な場合、パーツリストに記載されている部品を使用してください。

● 部品価格ランクは、予告なく変更することがあります。

ABBREVIATIONS IN THIS LIST ARE AS FOLLOWS:

C.A.EL.CHP	: CHIP ALUMI.ELECTROLYTIC CAP	L.EMIT	: LIGHT EMITTING MODULE
C.CE	: CERAMIC CAP	LED.DSPLY	: LED DISPLAY
C.CE.ARRAY	: CERAMIC CAP ARRAY	LED.INFRD	: LED,INFRARED
C.CE.CHP	: CHIP CERAMIC CAP	MODUL.RF	: MODULATOR,RF
C.CE.ML	: MULTILAYER CERAMIC CAP	PHOT.CPL	: PHOTO COUPLER
C.CE.M.CHP	: CHIP MULTILAYER CERAMIC CAP	PHOT.INTR	: PHOTO INTERRUPTER
C.CE.SAFTY	: RECOGNIZED CERAMIC CAP	PHOT.RFLCT	: PHOTO REFLECTOR
C.CE.TUBLR	: CERAMIC TUBULAR CAP	PIN.TEST	: PIN,TEST POINT
C.CE.SMI	: SEMI CONDUCTIVE CERAMIC CAP	PLST.RIVET	: PLASTIC RIVET
C.EL	: ELECTROLYTIC CAP	R.ARRAY	: RESISTOR ARRAY
C.MICA	: MICA CAP	R.CAR.	: CARBON RESISTOR
C.ML.FLM	: MULTILAYER FILM CAP	R.CAR.CHP	: CHIP RESISTOR
C.MP	: METALLIZED PAPER CAP	R.CAR.FP	: FLAME PROOF CARBON RESISTOR
C.MYLAR	: MYLAR FILM CAP	R.FUS	: FUSABLE RESISTOR
C.MYLAR.ML	: MULTILAYER MYLAR FILM CAP	R.MTL.CHP	: CHIP METAL FILM RESISTOR
C.PAPER	: PAPER CAPACITOR	R.MTL.FLM	: METAL FILM RESISTOR
C.PLS	: POLYSTYRENE FILM CAP	R.MTL.OXD	: METAL OXIDE FILM RESISTOR
C.POL	: POLYESTER FILM CAP	R.MTL.PLAT	: METAL PLATE RESISTOR
C.POLY	: POLYETHYLENE FILM CAP	RSNR.CE	: CERAMIC RESONATOR
C.PP	: POLYPROPYLENE FILM CAP	RSNR.CRYS	: CRYSTAL RESONATOR
C.TNTL	: TANTALUM CAP	R.TW.CEM	: TWIN CEMENT FIXED RESISTOR
C.TNTL.CHP	: CHIP TANTALUM CAP	R.CEMENT	: CEMENT RESISTOR
C.TRIM	: TRIMMER CAP	SCR.BND.HD	: BIND HEAD B-TITE SCREW
CN	: CONNECTOR	SCR.BW.HD	: BW HEAD TAPPING SCREW
CN.BS.PIN	: CONNECTOR,BASE PIN	SCR.CUP	: CUP TITE SCREW
CN.CANNON	: CONNECTOR,CANNON	SCR.TERM	: SCREW TERMINAL
CN.DIN	: CONNECTOR,DIN	SCR.TR	: SCREW,TRANSISTOR
CN.FLAT	: CONNECTOR,FLAT CABLE	SUPRT.PCB	: SUPPORT,P.C.B.
CN.POST	: CONNECTOR,BASE POST	SURG.PRTCT	: SURGE PROTECTOR
COIL.MX.AM	: COIL,AM MIX	SW.TACT	: TACT SWITCH
COIL.AT.FM	: COIL,FM ANTENNA	SW.LEAF	: LEAF SWITCH
COIL.DT.FM	: COIL,FM DETECT	SW.LEVER	: LEVER SWITCH
COIL.MX.FM	: COIL,FM MIX	SW.MICRO	: MICRO SWITCH
COIL.OUTPT	: OUTPUT COIL	SW.PUSH	: PUSH SWITCH
DIOD.ARRAY	: DIODE ARRAY	SW.RT.ENC	: ROTARY ENCODER
DIODE.BRG	: DIODE BRIDGE	SW.RT.MTR	: ROTARY SWITCH WITH MOTOR
DIODE.CHP	: CHIP DIODE	SW.RT	: ROTARY SWITCH
DIODE.VAR	: VARACTOR DIODE	SW.SLIDE	: SLIDE SWITCH
DIOD.Z.CHP	: CHIP ZENER DIODE	TERM.SP	: SPEAKER TERMINAL
DIODE.ZENR	: ZENER DIODE	TERM.WRAP	: WRAPPING TERMINAL
DSCR.CE	: CERAMIC DISCRIMINATOR	THRMST.CHP	: CHIP THERMISTOR
FER.BEAD	: FERRITE BEADS	TR.CHP	: CHIP TRANSISTOR
FER.CORE	: FERRITE CORE	TR.DGT	: DIGITAL TRANSISTOR
FET.CHP	: CHIP FET	TR.DGT.CHP	: CHIP DIGITAL TRANSISTOR
FL.DSPLY	: FLUORESCENT DISPLAY	TRANS	: TRANSFORMER
FLTR.CE	: CERAMIC FILTER	TRANS.PULS	: PULSE TRANSFORMER
FLTR.COMB	: COMB FILTER MODULE	TRANS.PWR	: POWER TRANSFORMER ASS'Y
FLTR.LC.RF	: LC FILTER,EMI	TUNER.AM	: TUNER PACK,AM
GND.MTL	: GROUND PLATE	TUNER.FM	: TUNER PACK,FM
GND.TERM	: GROUND TERMINAL	TUNER.PK	: FRONT-ENDTUNER PACK
HOLDER.FUS	: FUSE HOLDER	VR	: ROTARY POTENTIOMETER
IC.PRTCT	: IC PROTECTOR	VR.MTR	: POTENTIOMETER WITH MOTOR
JUMPER.CN	: JUMPER CONNECTOR	VR.SW	: POTENTIOMETER WITH ROTARY SW
JUMPER.TST	: JUMPER,TEST POINT	VR.SLIDE	: SLIDE POTENTIOMETER
L.DTCT	: LIGHT DETECTING MODULE	VR.TRIM	: TRIMMER POTENTIOMETER

P.C.B. DSP

Ref No.	Part No.	Description	Remarks	Markets	部 品 名	Rank	
*	WG078300	P. C. B.	DSP		JRTKABGL	P C B D S P	
*	WG078400	P. C. B.	DSP		UC	P C B D S P	
*	CB1	WE161800	CN	CAM-C16 4P SE	UC	シリアルバスコネクタ	
	CB2	VF982300	CN. BS. PIN	17P		F F Cコネクター	01
	CB3	VB858700	CN. BS. PIN	8P		ベースピン	01
	CB4-5	V9356900	CN	JE 19P SE		J Eコネクタープラグ	
	CB21	V9356900	CN	JE 19P SE		J Eコネクタープラグ	
	CB22	V0044900	CN. BS. PIN	19P		F F Cコネクター	01
	C5	US035100	C. CE. CHP	0.1uF 16V B	UC	チップセラコン	01
	C6	US035100	C. CE. CHP	0.1uF 16V B	UC	チップセラコン	01
	C7	US060500	C. CE. CHP	5pF 50V B	UC	チップセラコン	01
	C8	US035100	C. CE. CHP	0.1uF 16V B	UC	チップセラコン	01
	C9	US060500	C. CE. CHP	5pF 50V B	UC	チップセラコン	01
	C10-16	US035100	C. CE. CHP	0.1uF 16V B	UC	チップセラコン	01
	C17	US061470	C. CE. CHP	47pF 50V B	UC	チップセラコン	01
	C20	US061470	C. CE. CHP	47pF 50V B	UC	チップセラコン	01
	C23	US061470	C. CE. CHP	47pF 50V B	UC	チップセラコン	01
	C24-25	US035100	C. CE. CHP	0.1uF 16V B		チップセラコン	01
	C26	US135100	C. CE. CHP	0.1uF 16V		チップセラコン	01
	C29	US061470	C. CE. CHP	47pF 50V B		チップセラコン	01
	C30	US061470	C. CE. CHP	47pF 50V B		チップセラコン	01
	C31-33	US061220	C. CE. CHP	22pF 50V B		チップセラコン	01
	C34-39	US135100	C. CE. CHP	0.1uF 16V		チップセラコン	01
	C40-42	US135100	C. CE. CHP	0.1uF 16V		チップセラコン	01
	C43-45	UR237220	C. EL	22uF 16V		ケミコン	
	C46	UU238330	C. EL	330uF 16V		ケミコン FW	
	C47	UR237470	C. EL	47uF 16V		ケミコン	
	C48	US135100	C. CE. CHP	0.1uF 16V		チップセラコン	01
	C49	UR237470	C. EL	47uF 16V		ケミコン	
	C50-52	US135100	C. CE. CHP	0.1uF 16V		チップセラコン	01
	C53	UR237220	C. EL	22uF 16V		ケミコン	
	C54-55	US135100	C. CE. CHP	0.1uF 16V		チップセラコン	01
	C57	US135100	C. CE. CHP	0.1uF 16V		チップセラコン	01
	C58	UU238100	C. EL	100uF 16V		ケミコン	01
	C59	UR218100	C. EL	100uF 6.3V		ケミコン	
	C60	US135100	C. CE. CHP	0.1uF 16V		チップセラコン	01
	C62-63	US135100	C. CE. CHP	0.1uF 16V		チップセラコン	01
	C64	VE326000	C. MYLAR	0.1uF 50V		マイラーコン	01
	C65	VE326600	C. MYLAR	0.33uF 50V		マイラーコン	01
	C66	UA654220	C. MYLAR	0.022uF 50V J		マイラーコン	01
	C68	UR237470	C. EL	47uF 16V		ケミコン	
	C69	US135100	C. CE. CHP	0.1uF 16V		チップセラコン	01
	C70	US135100	C. CE. CHP	0.1uF 16V		チップセラコン	01
	C71	UR218100	C. EL	100uF 6.3V		ケミコン	
	C72	US135100	C. CE. CHP	0.1uF 16V		チップセラコン	01
	C74-75	US135100	C. CE. CHP	0.1uF 16V		チップセラコン	01
	C76	UU238100	C. EL	100uF 16V		ケミコン	
	C78	US135100	C. CE. CHP	0.1uF 16V		チップセラコン	01
	C80	UU267470	C. EL	47uF 50V		ケミコン FW	01
	C81	US061470	C. CE. CHP	47pF 50V B		チップセラコン	01
	C82	US135100	C. CE. CHP	0.1uF 16V		チップセラコン	01
	C83	UU267470	C. EL	47uF 50V		ケミコン FW	01
	C84	UU238100	C. EL	100uF 16V		ケミコン	
	C85-89	US135100	C. CE. CHP	0.1uF 16V		チップセラコン	01

* New Parts * 新規部品

P.C.B. DSP

Ref No.	Part No.	Description	Remarks	Markets	部 品 名	Rank
C90	US063100	C. CE. CHP	1000pF	50V B	チップセラコン	01
C91-93	US135100	C. CE. CHP	0.1uF	16V	チップセラコン	01
C94	UU219100	C. EL	1000uF	6.3V	ケミコン FW	01
C95	UU267470	C. EL	47uF	50V	ケミコン FW	01
C97	UR237100	C. EL	10uF	16V	ケミコン	
C98-99	US135100	C. CE. CHP	0.1uF	16V	チップセラコン	01
C100-118	US135100	C. CE. CHP	0.1uF	16V	チップセラコン	01
C119	UR237100	C. EL	10uF	16V	ケミコン	
C120	US126100	C. CE. CHP	1uF	10V	チップセラコン	01
C121-122	US135100	C. CE. CHP	0.1uF	16V	チップセラコン	01
C125	US135100	C. CE. CHP	0.1uF	16V	チップセラコン	01
C126	US062100	C. CE. CHP	100pF	50V B	チップセラコン	01
C129-131	US135100	C. CE. CHP	0.1uF	16V	チップセラコン	01
C132	UR237100	C. EL	10uF	16V	ケミコン	
C133-138	US135100	C. CE. CHP	0.1uF	16V	チップセラコン	01
C143-146	US135100	C. CE. CHP	0.1uF	16V	チップセラコン	01
C147-153	US061470	C. CE. CHP	47pF	50V B	チップセラコン	01
C154-170	US135100	C. CE. CHP	0.1uF	16V	チップセラコン	01
C171	UR238100	C. EL	100uF	16V	ケミコン	
C172	UU238100	C. EL	100uF	16V	ケミコン	
C173-174	US135100	C. CE. CHP	0.1uF	16V	チップセラコン	01
C175-177	US063100	C. CE. CHP	1000pF	50V B	チップセラコン	01
C178-179	US135100	C. CE. CHP	0.1uF	16V	チップセラコン	01
C180-182	US063100	C. CE. CHP	1000pF	50V B	チップセラコン	01
C183-184	US135100	C. CE. CHP	0.1uF	16V	チップセラコン	01
C185	UU238100	C. EL	100uF	16V	ケミコン	
C186	US035100	C. CE. CHP	0.1uF	16V B	チップセラコン	01
C187	UR237100	C. EL	10uF	16V	ケミコン	
C188	UR237220	C. EL	22uF	16V	ケミコン	
C189-190	US135100	C. CE. CHP	0.1uF	16V	チップセラコン	01
C191	UU267100	C. EL	10uF	50V	ケミコン FW	01
C192	US135100	C. CE. CHP	0.1uF	16V	チップセラコン	01
C193	UU267100	C. EL	10uF	50V	ケミコン FW	01
C194-198	US135100	C. CE. CHP	0.1uF	16V	チップセラコン	01
C199	UR237220	C. EL	22uF	16V	ケミコン	
C200	US135100	C. CE. CHP	0.1uF	16V	チップセラコン	01
C201	UU267100	C. EL	10uF	50V	ケミコン FW	01
C202	US135100	C. CE. CHP	0.1uF	16V	チップセラコン	01
C203	UU267100	C. EL	10uF	50V	ケミコン FW	01
C204	US135100	C. CE. CHP	0.1uF	16V	チップセラコン	01
C205-208	UA652100	C. MYLAR	100pF	50V J	マイラーコン	01
C209	US135100	C. CE. CHP	0.1uF	16V	チップセラコン	01
C210	US063470	C. CE. CHP	4700pF	50V B	チップセラコン	01
C211-212	UA654220	C. MYLAR	0.022uF	50V J	マイラーコン	01
C213	US062470	C. CE. CHP	470pF	50V B	チップセラコン	01
C214	US135100	C. CE. CHP	0.1uF	16V	チップセラコン	01
C215-218	UA652470	C. MYLAR	470pF	50V J	マイラーコン	01
C219	UR237100	C. EL	10uF	16V	ケミコン	
C220-221	US135100	C. CE. CHP	0.1uF	16V	チップセラコン	01
C222-224	UU267100	C. EL	10uF	50V	ケミコン FW	01
C225-227	US135100	C. CE. CHP	0.1uF	16V	チップセラコン	01
C228	UU267100	C. EL	10uF	50V	ケミコン FW	01
C229	US135100	C. CE. CHP	0.1uF	16V	チップセラコン	01
C230	UR237100	C. EL	10uF	16V	ケミコン	

* New Parts * 新規部品

P.C.B. DSP

Ref No.	Part No.	Description	Remarks	Markets	部 品 名	Rank
C231	UR237220	C. EL	22uF 16V		ケミコン	
C232-233	UU267220	C. EL	22uF 50V		ケミコン FW	01
C234-235	US135100	C. CE. CHP	0.1uF 16V		チップセラコン	01
C236-237	UR237470	C. EL	47uF 16V		ケミコン	
C238-241	US135100	C. CE. CHP	0.1uF 16V		チップセラコン	01
C242-243	US064100	C. CE. CHP	0.01uF 50V B	UC	チップセラコン	01
C244	US063470	C. CE. CHP	4700pF 50V B		チップセラコン	01
C245	US062470	C. CE. CHP	470pF 50V B		チップセラコン	01
C246-251	US135100	C. CE. CHP	0.1uF 16V		チップセラコン	01
C252	UR237100	C. EL	10uF 16V		ケミコン	
C253	UR837100	C. EL	10uF 16V	UC	ケミコン	01
C254	US135100	C. CE. CHP	0.1uF 16V		チップセラコン	01
C256	UR837470	C. EL	47uF 16V	UC	ケミコン	01
C257	US135100	C. CE. CHP	0.1uF 16V	UC	チップセラコン	01
C258	US135100	C. CE. CHP	0.1uF 16V		チップセラコン	01
C259-260	UR837470	C. EL	47uF 16V	UC	ケミコン	01
C261-263	US135100	C. CE. CHP	0.1uF 16V		チップセラコン	01
C264-265	UR837100	C. EL	10uF 16V	UC	ケミコン	01
C268-269	US135100	C. CE. CHP	0.1uF 16V	UC	チップセラコン	01
C270-271	UR837470	C. EL	47uF 16V	UC	ケミコン	01
C272	US135100	C. CE. CHP	0.1uF 16V		チップセラコン	01
C274	UU238100	C. EL	100uF 16V		ケミコン	
C279	US135100	C. CE. CHP	0.1uF 16V		チップセラコン	01
C283-288	US135100	C. CE. CHP	0.1uF 16V		チップセラコン	01
C289-294	UU238100	C. EL	100uF 16V		ケミコン	
C295-299	US135100	C. CE. CHP	0.1uF 16V		チップセラコン	01
C300	US135100	C. CE. CHP	0.1uF 16V		チップセラコン	01
C301-306	UU267100	C. EL	10uF 50V		ケミコン FW	01
C307-312	UU238100	C. EL	100uF 16V		ケミコン	
C313-318	US135100	C. CE. CHP	0.1uF 16V		チップセラコン	01
C319-323	UA652560	C. MYLAR	560pF 50V J		マイラーコン	02
C324-328	UA653680	C. MYLAR	6800pF 50V J		マイラーコン	01
C329-330	UA654560	C. MYLAR	0.056uF 50V J		マイラーコン	
C331-334	UA653680	C. MYLAR	6800pF 50V J		マイラーコン	01
C335-339	UA652390	C. MYLAR	390pF 50V J		マイラーコン	01
C340-341	UA654150	C. MYLAR	0.015uF 50V J		マイラーコン	01
C342-350	UA652390	C. MYLAR	390pF 50V J		マイラーコン	01
C351-352	UA654150	C. MYLAR	0.015uF 50V J		マイラーコン	01
C353-356	UA652390	C. MYLAR	390pF 50V J		マイラーコン	01
C368-374	UU267100	C. EL	10uF 50V		ケミコン FW	01
C375-376	UR237100	C. EL	10uF 16V		ケミコン	
C377-378	UU267100	C. EL	10uF 50V		ケミコン FW	01
C379-390	US135100	C. CE. CHP	0.1uF 16V		チップセラコン	01
C391-396	UR237470	C. EL	47uF 16V		ケミコン	
C399	US061470	C. CE. CHP	47pF 50V B		チップセラコン	01
C400	US061470	C. CE. CHP	47pF 50V B		チップセラコン	01
C401-409	US135100	C. CE. CHP	0.1uF 16V		チップセラコン	01
C411-412	US135100	C. CE. CHP	0.1uF 16V		チップセラコン	01
C413-419	US163100	C. CE. CHP	1000pF 50V		チップセラコン	01
C423	US063100	C. CE. CHP	1000pF 50V B		チップセラコン	01
C426	UU238100	C. EL	100uF 16V	UC	ケミコン	
C531-534	UA653270	C. MYLAR	2700pF 50V J	UC	マイラーコン	01
C535-548	US061470	C. CE. CHP	47pF 50V B		チップセラコン	01
C551-573	US135100	C. CE. CHP	0.1uF 16V		チップセラコン	01

* New Parts * 新規部品

P.C.B. DSP

Ref No.	Part No.	Description	Remarks	Markets	部 品 名	Rank
C574-594	US163100	C. CE. CHP	1000pF 50V		チップセラコン	01
C595-599	US135100	C. CE. CHP	0.1uF 16V		チップセラコン	01
C600-608	US135100	C. CE. CHP	0.1uF 16V		チップセラコン	01
D1	WE674800	DIODE	AVRL161A1R1NTB	UC	チップバリスタ	01
D2	WE674800	DIODE	AVRL161A1R1NTB	UC	チップバリスタ	01
D3	WE674800	DIODE	AVRL161A1R1NTB	UC	チップバリスタ	01
D5	VT332900	DIODE	1SS355		ダイオード	01
D7	VT332900	DIODE	1SS355		ダイオード	01
D13	VT332900	DIODE	1SS355		ダイオード	01
D14-19	VW220700	DIODE. SHOT	RB501V-40		ショットキーダイオード	01
D20-23	VW220700	DIODE. SHOT	RB501V-40		ショットキーダイオード	01
IC501	X3936A00	IC	SN74LVU04APWR		ロジックIC	
IC502	X3018A00	IC	SN74AHCT00PWR NAND		ロジックIC	01
IC504-505	XN518A00	IC	SN74LS151NSR 8-1 S		ロジックIC	04
* IC506	X6989A00	IC	LC89057W-VF4A-E		IC	
IC507	X5945A00	IC	P0012FZ01ZPH		電源IC	05
IC508	XZ003A00	IC	P0025EZ5MZP 2.5V		電源IC	03
IC509	X6051A00	IC	UPC29M33T-E1-AZ		電源IC	04
IC510	X2080A00	IC	SN74AHCT1G32DCKR		ロジックIC	01
IC511	X3824A00	IC	SN74AHCT08PWR		ロジックIC	01
IC513	X3693A00	IC	SN74LV245APWR TRAN		ロジックIC	
IC514	X6123A00	IC	SN74LV157APWR		ロジックIC	02
IC515	X2590B00	IC	W9816G6CH-7 SDRAM		メモリIC 16M	06
IC516	X3567A00	IC	YSS930-SZ		IC	08
IC517	XV077B00	IC	MSM514260E-60JS		メモリIC 4M	07
IC518	X3567A00	IC	YSS930-SZ		IC	08
IC520	X3505A00	IC	NJM2068MD-TE2		アンプIC	02
IC525-528	X5482A00	IC	NE5532DR 0P AMP	UC	アンプIC	
IC529-530	X3505A00	IC	NJM2068MD-TE2		アンプIC	02
IC532	X6123A00	IC	SN74LV157APWR		ロジックIC	02
IC533-534	XV894A00	IC	TC74VHC153FT MULTI		ロジックIC	03
IC539-540	X3505A00	IC	NJM2068MD-TE2		アンプIC	02
* IC541	X6231A00	IC	AK4384ET	UC	IC	
* IC542	X7016A00	IC	MX29LV400BC-70G		メモリIC	
* IC550	X6227B00	IC	F2602E-01	UC	CPU/周辺IC	
IC551	X2080A00	IC	SN74AHCT1G32DCKR	UC	ロジックIC	01
IC552	X3693A00	IC	SN74LV245APWR TRAN	UC	ロジックIC	
IC560	X5482A00	IC	NE5532DR 0P AMP	UC	アンプIC	
* IC564-569	X6873A00	IC	PCM1791ADBR		D/Aコンバーター	
* IC570	X6872A00	IC	PCM1804DBR		A/Dコンバーター	
IC571	X3833A00	IC	SN74AHC1G08DCKR		ロジックIC	01
* PJ1	WF860400	JACK. PIN	LPR6520-G080FM		ピンジャック 3P	
PN1	V9637500	PIN	L=70 #18		スタイルピン	
Q6	VD303700	TR	2SC3326 A,B		トランジスタ	01
Q19	VW655400	TR. DGT	DTC114EKA		デジタルトランジスタ	01
R1		R. CHP	0Ω 1/16W J	UC	チップ抵抗	
R2		R. CHP	0Ω 1/16W J	UC	チップ抵抗	
R3		R. CHP	100Ω 1/16W J	UC	チップ抵抗	
R4		R. CHP	100Ω 1/16W J	UC	チップ抵抗	
R5		R. CHP	1KΩ 1/16W J	UC	チップ抵抗	
R6		R. CHP	1KΩ 1/16W J	UC	チップ抵抗	
R7		R. CHP	470Ω 1/16W J	UC	チップ抵抗	
R8		R. CHP	1MΩ 1/16W J	UC	チップ抵抗	

* New Parts * 新規部品

P.C.B. DSP & P.C.B. FUNCTION

Ref No.	Part No.	Description	Remarks	Markets	部 品 名	Rank	
R9		R. CHP	47Ω 1/16W J		UC	チップ抵抗	
R10-11		R. CHP	47Ω 1/16W J		UC	チップ抵抗	
R12		R. CHP	22Ω 1/16W J		UC	チップ抵抗	
R13-14		R. CHP	470KΩ 1/16W J		UC	チップ抵抗	
R15-18		R. CHP	100KΩ 1/16W J		UC	チップ抵抗	
R19		R. CHP	100Ω 1/16W J		UC	チップ抵抗	
R20		R. CHP	100Ω 1/16W J		UC	チップ抵抗	
R21		R. CHP	47Ω 1/16W J		UC	チップ抵抗	
R22-23		R. CHP	100Ω 1/16W J		UC	チップ抵抗	
R24-25		R. CHP	47Ω 1/16W J		UC	チップ抵抗	
R41-42	HV753100	R. CAR. FP	1Ω 1/4W			不燃化カーボン抵抗	01
R52-53	V8070000	R. MTL. FLM	1Ω 1W			金属被膜抵抗	
R59	HV753100	R. CAR. FP	1Ω 1/4W			不燃化カーボン抵抗	01
R76	V8070000	R. MTL. FLM	1Ω 1W			金属被膜抵抗	
R98	HV753100	R. CAR. FP	1Ω 1/4W			不燃化カーボン抵抗	01
R246		R. CHP	10KΩ 1/16W J		UC	チップ抵抗	
R252-253	V8070100	R. MTL. FLM	2.2Ω 1W			金属被膜抵抗	
R263-266		R. CHP	47Ω 1/16W J		UC	チップ抵抗	
R273	HV753100	R. CAR. FP	1Ω 1/4W		UC	不燃化カーボン抵抗	01
R277-278		R. CHP	10KΩ 1/16W J		UC	チップ抵抗	
R280-281		R. MTL. CHP	3.3KΩ 1/16W D		UC	チップ金属被膜抵抗	
R282-283		R. MTL. CHP	2.2KΩ 1/16W D		UC	チップ金属被膜抵抗	
R288-289		R. CHP	47KΩ 1/16W J		UC	チップ抵抗	
R294-295		R. CHP	1KΩ 1/16W J		UC	チップ抵抗	
R296	HV753100	R. CAR. FP	1Ω 1/4W		UC	不燃化カーボン抵抗	01
R298	HV753100	R. CAR. FP	1Ω 1/4W		UC	不燃化カーボン抵抗	01
R365-370	HV753470	R. CAR. FP	4.7Ω 1/4W			不燃化カーボン抵抗	01
R371-374	V8070000	R. MTL. FLM	1Ω 1W			金属被膜抵抗	01
R398-399	V8070000	R. MTL. FLM	1Ω 1W			金属被膜抵抗	
R549-552		R. CHP	100KΩ 1/16W J		JRTKABGL	チップ抵抗	
R573		R. CHP	10Ω 1/16W J		UC	チップ抵抗	
R971		R. CHP	1.8KΩ 1/16W J		UC	チップ抵抗	
R972-973		R. CHP	1.5KΩ 1/16W J		UC	チップ抵抗	
R974		R. CHP	1.8KΩ 1/16W J		UC	チップ抵抗	
T1	WG095100	SCR. TERM	(CUT) CU			ネジ端子	
T2	WG095100	SCR. TERM	(CUT) CU			ネジ端子	
U1	WB920900	CN. PHOT. SN	1P GP1FA513TZOF			光ファイバデータ端子	03
U2	WB920900	CN. PHOT. SN	1P GP1FA513TZOF			光ファイバデータ端子	03
U3	WB547900	CN. PHOT. SN	1P GP1FA513RZOF			光ファイバ受信器	03
U4	WB547900	CN. PHOT. SN	1P GP1FA513RZOF			光ファイバ受信器	03
U5	WB547900	CN. PHOT. SN	1P GP1FA513RZOF			光ファイバ受信器	03
U6	WB547900	CN. PHOT. SN	1P GP1FA513RZOF			光ファイバ受信器	03
* XL1	WE436500	RSNR. CRYST	45.1584MHz DSX840GA		UC	水晶振動子	
XL2	V6931900	RESONATOR	24.576MHz DS0751SV			水晶発振器	05
* * * * *	WG079100	P. C. B.	FUNCTION		J	P C B ファンクション	
* * * * *	WG079200	P. C. B.	FUNCTION		UC	P C B ファンクション	
* * * * *	WG079300	P. C. B.	FUNCTION		R	P C B ファンクション	
* * * * *	WG079400	P. C. B.	FUNCTION		T	P C B ファンクション	
* * * * *	WG079500	P. C. B.	FUNCTION		K	P C B ファンクション	
* * * * *	WG079600	P. C. B.	FUNCTION		A	P C B ファンクション	
* * * * *	WG079700	P. C. B.	FUNCTION		BG	P C B ファンクション	

* New Parts * 新規部品

P.C.B. FUNCTION

Ref No.	Part No.	Description	Remarks	Markets	部 品 名	Rank
*	WG079800	P.C.B.	FUNCTION		L	P C B ファンクション
	CB301	VB858700 CN. BS. PIN	8P			ベースピン 01
	CB303	VM929900 CN. BS. PIN	15P			F P Cコネクター 01
	CB304	VQ046000 CN. BS. PIN	31P			F F Cコネクター 03
	CB305	VB858800 CN. BS. PIN	9P			ベースピン 01
	CB306	LB919060 CN. BS. PIN	6P			ベース付ポスト 01
*	CB307	V8810200 CN	JE 9P TE			J Eコネクター 02
*	CB308	VU446000 CN	JE 15P TE			J E コネクタ 02
	CB309-310	V8875600 CN	JE 13P TE			J Eコネクター 02
	CB311	V7826400 CN	14P TE TUC SERIES			コネクタープラグ
	CB312	V7826100 CN	11P TE TUC SERIES			コネクタープラグ 01
	CB313	V8875600 CN	JE 13P TE			J Eコネクター 02
	CB314-315	V9357000 CN	JE 19P TE			J Eコネクター
*	CB316	VU446000 CN	JE 15P TE			J E コネクタ 02
	CB317-319	V9357000 CN	JE 19P TE			J Eコネクター
*	CB601	VU443800 CN	JE 15P SE			J Eコネクタープラグ 01
	CB602	VB390100 CN. BS. PIN	5P			ベースピン 01
	CB603	VB390500 CN. BS. PIN	9P			コネクタベースポスト 03
	CB604	VQ047400 CN. BS. PIN	19P			F F Cコネクター 01
	CB605	LB919040 CN. BS. PIN	4P			ベース付ポスト 01
	CB606	VB389800 CN. BS. PIN	2P			ベースピン 01
	CB607	VB390200 CN. BS. PIN	6P			コネクタベースポスト 01
	CB608	LB918020 CN. BS. PIN	2P			ベース付ポスト 01
	C301	UR239100 C. EL	1000uF 16V			ケミコン
	C303	US063100 C. CE. CHP	1000pF 50V B			チップセラコン 01
	C304	UR067100 C. EL	10uF 50V			ケミコン 01
	C305	WB165500 C. EL	0.33F 5.5V			ゴールドキャパシタ
	C306-307	UR219100 C. EL	1000uF 6.3V			ケミコン
	C308	US064100 C. CE. CHP	0.01uF 50V B			チップセラコン 01
	C309	UR238100 C. EL	100uF 16V			ケミコン
	C310-326	US135100 C. CE. CHP	0.1uF 16V			チップセラコン 01
	C327-334	UR266220 C. EL	2.2uF 50V			ケミコン
	C335	UR239100 C. EL	1000uF 16V			ケミコン
	C338	US064100 C. CE. CHP	0.01uF 50V B			チップセラコン 01
	C339	UR266220 C. EL	2.2uF 50V			ケミコン
	C340	UR237470 C. EL	47uF 16V			ケミコン
	C341	US135100 C. CE. CHP	0.1uF 16V	BG		チップセラコン 01
	C342-343	US062330 C. CE. CHP	330pF 50V B	BG		チップセラコン 01
	C344	US062560 C. CE. CHP	560pF 50V B	BG		チップセラコン 01
	C345-346	UR237470 C. EL	47uF 16V	BG		ケミコン
	C347-348	US061270 C. CE. CHP	27pF 50V B	BG		チップセラコン 01
	C349	UR237470 C. EL	47uF 16V	BG		ケミコン
	C350	US135100 C. CE. CHP	0.1uF 16V	BG		チップセラコン 01
	C351	US135100 C. CE. CHP	0.1uF 16V			チップセラコン 01
	C352	UR267470 C. EL	47uF 50V			ケミコン
	C353	UR237470 C. EL	47uF 16V			ケミコン
	C354	US135100 C. CE. CHP	0.1uF 16V			チップセラコン 01
	C355-356	UR267470 C. EL	47uF 50V			ケミコン
	C358-359	US062100 C. CE. CHP	100pF 50V B			チップセラコン 01
	C361-362	US062100 C. CE. CHP	100pF 50V B			チップセラコン 01
	C365-366	US062100 C. CE. CHP	100pF 50V B			チップセラコン 01
	C368-375	US062100 C. CE. CHP	100pF 50V B			チップセラコン 01
	C378-388	US062100 C. CE. CHP	100pF 50V B			チップセラコン 01
	C392	US062100 C. CE. CHP	100pF 50V B			チップセラコン 01

* New Parts * 新規部品

P.C.B. FUNCTION

Ref No.	Part No.	Description	Remarks	Markets	部 品 名	Rank
C394-399	US062100	C. CE. CHP	100pF 50V B		チップセラコン	01
C400-402	US062100	C. CE. CHP	100pF 50V B		チップセラコン	01
C403	US135100	C. CE. CHP	0.1uF 16V		チップセラコン	01
C404	UR218220	C. EL	220uF 6.3V		ケミコン	
C405	US135100	C. CE. CHP	0.1uF 16V		チップセラコン	01
C406-407	US064100	C. CE. CHP	0.01uF 50V B		チップセラコン	01
C408-409	US062100	C. CE. CHP	100pF 50V B		チップセラコン	01
C410-413	US135100	C. CE. CHP	0.1uF 16V		チップセラコン	01
C601-602	UR237100	C. EL	10uF 16V		ケミコン	
C603	US135220	C. CE. CHP	0.22uF 16V		チップセラコン	01
C604-605	US135100	C. CE. CHP	0.1uF 16V		チップセラコン	01
C606-607	UR267470	C. EL	47uF 50V		ケミコン	
C608	US135100	C. CE. CHP	0.1uF 16V		チップセラコン	01
C609-612	UR237100	C. EL	10uF 16V		ケミコン	
C613	US135100	C. CE. CHP	0.1uF 16V		チップセラコン	01
C614-618	UR237100	C. EL	10uF 16V		ケミコン	
C619-625	UR238100	C. EL	100uF 16V		ケミコン	
C626-627	US062100	C. CE. CHP	100pF 50V B		チップセラコン	01
C628-630	UT952100	C. PP	100pF 100V		PPコン	
C631-634	US062100	C. CE. CHP	100pF 50V B		チップセラコン	01
C635-636	UR266470	C. EL	4.7uF 50V		ケミコン	
C637-638	UR267470	C. EL	47uF 50V		ケミコン	
C639	UR266470	C. EL	4.7uF 50V		ケミコン	
C640-641	UR237100	C. EL	10uF 16V		ケミコン	
C642-643	UR266470	C. EL	4.7uF 50V		ケミコン	
C644-645	UR266330	C. EL	3.3uF 50V		ケミコン	
C646-651	US135100	C. CE. CHP	0.1uF 16V		チップセラコン	01
C652	UR237470	C. EL	47uF 16V		ケミコン	
C653	US135100	C. CE. CHP	0.1uF 16V		チップセラコン	01
C654	WG781200	C. EL	33uF 25V		ケミコン	
C655	UR267470	C. EL	47uF 50V		ケミコン	
C656	WG782300	C. EL	10uF 50V		ケミコン	
C657	WG781200	C. EL	33uF 25V		ケミコン	
C658	UR237470	C. EL	47uF 16V		ケミコン	
C659	WG781200	C. EL	33uF 25V		ケミコン	
C660	UR237100	C. EL	10uF 16V		ケミコン	
C661	WG781200	C. EL	33uF 25V		ケミコン	
C662	UR267470	C. EL	47uF 50V		ケミコン	
C663-665	WG781200	C. EL	33uF 25V		ケミコン	
C666	US135100	C. CE. CHP	0.1uF 16V		チップセラコン	01
C667-668	UR237470	C. EL	47uF 16V		ケミコン	
C669-670	US061470	C. CE. CHP	47pF 50V B		チップセラコン	01
C671	US062100	C. CE. CHP	100pF 50V B		チップセラコン	01
C672-673	UR237100	C. EL	10uF 16V		ケミコン	
C674-675	UT952100	C. PP	100pF 100V		PPコン	
C676-681	UU267100	C. EL	10uF 50V		ケミコン FW	01
C682-683	UR267470	C. EL	47uF 50V		ケミコン	
C684	UR237220	C. EL	22uF 16V		ケミコン	
C685-686	UU267100	C. EL	10uF 50V		ケミコン FW	01
C687	UR237220	C. EL	22uF 16V		ケミコン	
C688-689	US135100	C. CE. CHP	0.1uF 16V		チップセラコン	01
C690-691	UR267470	C. EL	47uF 50V		ケミコン	
C693	US135100	C. CE. CHP	0.1uF 16V		チップセラコン	01
C695	US135100	C. CE. CHP	0.1uF 16V		チップセラコン	01

* New Parts * 新規部品

P.C.B. FUNCTION

Ref No.	Part No.	Description	Remarks	Markets	部 品 名	Rank
D301	VW833200	DIODE	1SS380		ダイオード	01
D302-307	VT332900	DIODE	1SS355		ダイオード	01
D308	VU992600	DIODE.ZENR	MA8051-M 5.1V		ツェナーダイオード	01
D309-310	VT332900	DIODE	1SS355		ダイオード	01
D311	VU172000	DIODE.ZENR	UDZS5.6BTE-17 5.6V		ツェナーダイオード	01
D312	VU993700	DIODE.ZENR	MA8068-L 6.6V		ツェナーダイオード	
D313	VU995300	DIODE.ZENR	MA8100-L 9.7V		ツェナーダイオード	01
D314	VU993700	DIODE.ZENR	MA8068-L 6.6V		ツェナーダイオード	
D601-604	VT332900	DIODE	1SS355		ダイオード	01
D605-606	VU993700	DIODE.ZENR	MA8068-L 6.6V		ツェナーダイオード	
* IC301	X6909A00	IC CPU	M30845FJGP	unwritten	IC CPU	
IC302	X0082A00	IC	LC72722PM		IC SOP	
IC571	X5886A00	IC	RH5RE58AA-T1-FA		電源IC	04
IC601	X5044A00	IC	NJU7311AM		アナログIC	05
IC602	X5045A00	IC	NJU7312AM		アナログIC	
IC603	X5044A00	IC	NJU7311AM		アナログIC	05
IC604	X5043A00	IC	NJU7313AM		アナログIC	
IC605-609	X3505A00	IC	NJM2068MD-TE2		アンプIC SOP	02
* IC610	X5574A00	IC	YAC526-EZE2		IC アナログ	
IC611	X4325A00	IC	YAC523-EVR2		IC, アナログ	06
IC612	XF291A00	IC	uPC4570G2		IC	03
IC613	X3505A00	IC	NJM2068MD-TE2		アンプIC SOP	02
IC614	XF291A00	IC	uPC4570G2		IC	03
IC615	XF291A00	IC	uPC4570G2		IC	03
IC616	XF291A00	IC	uPC4570G2		IC	03
J604		R. CHP	0Ω 1/16W J	JUC	チップ抵抗	
J605		R. CHP	0Ω 1/16W J	JUC	チップ抵抗	
PN301	V9637500	PIN	L=70 #18		スタイルピン	
PN601-606	V9637500	PIN	L=70 #18		スタイルピン	
Q301	WD974200	TR	2SA1036KT146 P,Q,R		トランジスタ	01
Q302	VW556500	TR	2SA1037K Q,R,S		トランジスタ	01
Q303-306	VD303700	TR	2SC3326 A,B		トランジスタ	01
Q307	iC287820	TR	2SC2878 A,B		トランジスタ	01
* Q308-315	WF767900	FET	5HP01C-TB-E		FET	
Q323	VD303700	TR	2SC3326 A,B		トランジスタ	01
Q324	iC181510	TR	2SC1815 Y		トランジスタ	01
Q325	VD303700	TR	2SC3326 A,B	BG	トランジスタ	01
Q326-327	VP872700	TR	2SC4488 S,T		トランジスタ	01
Q328	VP872600	TR	2SA1708 S,T		トランジスタ	01
Q603	VP872700	TR	2SC4488 S,T		トランジスタ	01
Q604	VP872600	TR	2SA1708 S,T		トランジスタ	01
Q605-606	VZ725900	TR	2SD1938F S,T		トランジスタ	
Q609-610	VZ725900	TR	2SD1938F S,T		トランジスタ	
Q613-628	VZ725900	TR	2SD1938F S,T		トランジスタ	
R301	VP939800	R. MTL. OXD	10Ω 1W		酸化金属被膜抵抗	01
R357		R. CHP	0Ω 1/16W J	J	チップ抵抗	
R357		R. CHP	1.2KΩ 1/16W J	UC	チップ抵抗	
R357		R. CHP	4.7KΩ 1/16W J	R	チップ抵抗	
R357		R. CHP	6.8KΩ 1/16W J	T	チップ抵抗	
R357		R. CHP	10KΩ 1/16W J	K	チップ抵抗	
R357		R. CHP	15KΩ 1/16W J	A	チップ抵抗	
R357		R. CHP	47KΩ 1/16W J	BG	チップ抵抗	
R357		R. CHP	100KΩ 1/16W J	L	チップ抵抗	
R503		R. CHP	33KΩ 1/16W J	BG	チップ抵抗	

* New Parts * 新規部品

P.C.B. FUNCTION & P.C.B. OPERATION

Ref No.	Part No.	Description	Remarks	Markets	部 品 名	Rank	
R504		R. CHP	100K Ω 1/16W J		BG	チップ抵抗	
R505		R. CHP	2.2K Ω 1/16W J		BG	チップ抵抗	
R506		R. CHP	100 Ω 1/16W J		BG	チップ抵抗	
R507		R. CHP	22K Ω 1/16W J		BG	チップ抵抗	
R508-509		R. CHP	470 Ω 1/16W J		BG	チップ抵抗	
R510		R. CHP	10K Ω 1/16W J		BG	チップ抵抗	
R511		R. CHP	470 Ω 1/16W J		BG	チップ抵抗	
R512		R. CHP	10K Ω 1/16W J		BG	チップ抵抗	
R677-678	V8070200	R. MTL. FLM	4.7 Ω 1W			金属被膜抵抗	
R723	HF355330	R. CAR	330 Ω 1/2W			カーボン抵抗	
R728		R. CHP	56 Ω 1/16W J		JUC	チップ抵抗	
R728		R. CHP	100 Ω 1/16W J		RTKABGL	チップ抵抗	
R729		R. CHP	56 Ω 1/16W J		JUC	チップ抵抗	
R729		R. CHP	100 Ω 1/16W J		RTKABGL	チップ抵抗	
R736		R. CHP	56 Ω 1/16W J		JUC	チップ抵抗	
R736		R. CHP	120 Ω 1/16W J		RTKABGL	チップ抵抗	
R737		R. CHP	56 Ω 1/16W J		JUC	チップ抵抗	
R737		R. CHP	120 Ω 1/16W J		RTKABGL	チップ抵抗	
T301	WG095100	SCR. TERM	(CUT) CU			ネジ端子	
* XL301	WF997400	RSNR. CE	20MHz			セラミック振動子	
* XL302	V7556000	RSNR. CRY	4.332MHz HC-49U		BG	水晶振動子	
* * * * *	WG083000	P. C. B.	OPERATION		JUC	P C B オペレーション	
* * * * *	WG083100	P. C. B.	OPERATION		RTKABGL	P C B オペレーション	
CB901	VB389800	CN. BS. PIN	2P			ベースピン	01
CB903	VB858500	CN. BS. PIN	6P			ベースピン	01
CB904	VB390000	CN. BS. PIN	4P			ベースピン	01
CB905	VB389900	CN. BS. PIN	3P			ベースピン	01
CB906	VB390200	CN. BS. PIN	6P			コネクタベースポスト	01
CB907	VB390300	CN. BS. PIN	7P			ベースピン	01
CB908	VB390000	CN. BS. PIN	4P			ベースピン	01
CB909	VF982300	CN. BS. PIN	17P			F F Cコネクター	01
CB910	V0047200	CN. BS. PIN	9P			F F Cコネクター	01
CB911	V7825900	CN	9P TE TUC SERIES			コネクタープラグ	
CB912	V0046000	CN. BS. PIN	31P			F F Cコネクター	03
CB913	VP798200	CN. BS. PIN	24P			F F Cコネクター	01
C904-910	US061220	C. CE. CHP	22pF 50V B			チップセラコン	01
C911	US135100	C. CE. CHP	0.1uF 16V			チップセラコン	01
C912-915	US063100	C. CE. CHP	1000pF 50V B			チップセラコン	01
C921-922	US063100	C. CE. CHP	1000pF 50V B			チップセラコン	01
C927	US135100	C. CE. CHP	0.1uF 16V			チップセラコン	01
C928-929	UM397220	C. EL	22uF 25V			ケミコン	01
C930	US135100	C. CE. CHP	0.1uF 16V			チップセラコン	01
C931	UM397100	C. EL	10uF 16V			ケミコン	01
C932	UA653100	C. MYLAR	1000pF 50V J			マイラーコン	03
C933	US064100	C. CE. CHP	0.01uF 50V B			チップセラコン	01
C934	UA653100	C. MYLAR	1000pF 50V J			マイラーコン	03
C937	US061330	C. CE. CHP	33pF 50V B			チップセラコン	01
C939	UM387470	C. EL	47uF 16V			ケミコン	01
C940	UM397470	C. EL	47uF 16V			ケミコン	01
C941-942	US062470	C. CE. CHP	470pF 50V B			チップセラコン	01
C943	US063100	C. CE. CHP	1000pF 50V B			チップセラコン	01

* New Parts * 新規部品

P.C.B. OPERATION & P.C.B. MAIN

Ref No.	Part No.	Description	Remarks	Markets	部 品 名	Rank
C946	US135100	C. CE. CHP	0.1uF 16V		チップセラコン	01
C949	UM397220	C. EL	22uF 25V		ケミコン	01
C950-951	US135100	C. CE. CHP	0.1uF 16V		チップセラコン	01
C952	US062100	C. CE. CHP	100pF 50V B		チップセラコン	01
C955-956	US063100	C. CE. CHP	1000pF 50V B		チップセラコン	01
C959	UM397100	C. EL	10uF 16V		ケミコン	01
C960	US063100	C. CE. CHP	1000pF 50V B		チップセラコン	01
C965	US135100	C. CE. CHP	0.1uF 16V		チップセラコン	01
C973	US135100	C. CE. CHP	0.1uF 16V		チップセラコン	01
C974-975	US062100	C. CE. CHP	100pF 50V B		チップセラコン	01
C976	US135100	C. CE. CHP	0.1uF 16V		チップセラコン	01
C978	US135100	C. CE. CHP	0.1uF 16V	JUC	チップセラコン	01
C979	UM397100	C. EL	10uF 16V		ケミコン	01
C980-983	US062100	C. CE. CHP	100pF 50V B		チップセラコン	01
C984-985	UR237100	C. EL	10uF 16V		ケミコン	
C986-987	US061100	C. CE. CHP	10pF 50V B		チップセラコン	01
C988-989	WB553000	C. EL	1000uF 16V		ケミコン VK	
C990	UM397100	C. EL	10uF 16V		ケミコン	01
C991-992	US135100	C. CE. CHP	0.1uF 16V		チップセラコン	01
D903	WB071400	LED	BE SLR343BBT		LED	03
D906	VU171900	DIODE. ZENR	UDZ5.1B 5.1V		ツェナーダイオード	01
D932-933	VV307700	DIODE	1N4002S		ダイオード	01
IC902	X2080A00	IC	SN74AHCT1G32DCKR		ロジックIC	01
IC903	XS377A00	IC	BA15218F OP AMP		アンプIC	01
IC904	XF291A00	IC	uPC4570G2		IC	03
J910		R. CHP	0Ω 1/16W J	RTKABGL	チップ抵抗	
JK901	V9408200	JACK. PHONE	MSJ-064-05B GR		ホーンジャック	03
JK902	V2589500	CN. DIN	1P		ミニDINコネクタ	02
* JK903	V9435700	JACK. MNI	MSJ-035-12APC		モノラル ミニジャック	
PJ901	V6222800	JACK. PIN	3P		ピンジャック	04
PN903-906	V9637500	PIN	L=70 #18		スタイルピン	
Q901	VV556400	TR	2SC2412K Q,R,S		トランジスタ	01
Q915-916	VZ725900	TR	2SD1938F S,T		トランジスタ	
R1000-1001	HF355100	R. CAR	100Ω 1/2W		カーボン抵抗	
* R1011-1012	HL005220	R. MTL. OXD	220Ω 1/2W		酸化金属被膜抵抗	
SW904	WF875900	SW. PUSH	SPUN127100		プッシュSW	
SW908	V4757100	SW. TACT	EVQ11A		タクトSW	01
SW909	V6578000	SW. RT. ENC	RB161PVB20FHINA		ロータリーエンコーダ	04
SW910	V9281200	SW. RT. ENC	EVEGC1F2512B		ロータリーエンコーダ	02
SW912	V4757100	SW. TACT	EVQ11A		タクトSW	01
SW920	V9281200	SW. RT. ENC	EVEGC1F2512B		ロータリーエンコーダ	02
SW924	V4757100	SW. TACT	EVQ11A		タクトSW	01
U902	WB547900	CN. PHOT. SN	1P GP1FA513RZOF		光ファイバー受信器	03
* * * *	WG075400	P. C. B.	MAIN	J	P C B メイン	
	WG075500	P. C. B.	MAIN	UC	P C B メイン	
	WG075600	P. C. B.	MAIN	RTA	P C B メイン	
	WG075700	P. C. B.	MAIN	KBGL	P C B メイン	
CB205	V7825800	CN	8P TE TUC SERIES		コネクタプラグ	
CB206	V7825500	CN	5P TE TUC SERIES		コネクタプラグ	01
CB208	LB918030	CN. BS. PIN	3P		ベース付ポスト	01
CB211	WB127100	CN. BS. PIN	3P TE XH		ベース付ポスト	

* New Parts * 新規部品

P.C.B. MAIN

Ref No.	Part No.	Description	Remarks	Markets	部 品 名	Rank
CB212	LB932060	CN. BS. PIN	6P		ベースポスト	01
CB215	VB390300	CN. BS. PIN	7P		ベースピン	01
CB216	LB918020	CN. BS. PIN	2P		ベース付ポスト	01
CB217	V7826100	CN	11P TE TUC SERIES		コネクタプラグ	01
CB218	V7825400	CN	4P TE TUC SERIES		コネクタプラグ	01
CB219	VB390400	CN. BS. PIN	8P		ベースピン	01
C201	VJ599100	C. CE. TUBLR	0.1uF 50V		円筒セラコン	01
C202	WE100900	C. PP	220pF 630V		PPコン	
C226	VJ599100	C. CE. TUBLR	0.1uF 50V		円筒セラコン	01
C234	WE100500	C. PP	100pF 630V		PPコン	
C235	UR297100	C. EL	10uF 100V		ケミコン	
C236-237	WE100500	C. PP	100pF 630V		PPコン	
C238	UR297100	C. EL	10uF 100V		ケミコン	
C239-240	WE100500	C. PP	100pF 630V		PPコン	
C241	UR397100	C. EL	10uF 100V		ケミコン	03
C242-243	WE100500	C. PP	100pF 630V		PPコン	
C244	UR397100	C. EL	10uF 100V		ケミコン	03
C245-246	WE100500	C. PP	100pF 630V		PPコン	
C247	UR297100	C. EL	10uF 100V		ケミコン	
C248-249	WE100500	C. PP	100pF 630V		PPコン	
C250	UR297100	C. EL	10uF 100V		ケミコン	
C251-252	WE100500	C. PP	100pF 630V		PPコン	
C253	UR297100	C. EL	10uF 100V		ケミコン	
C254	WE100500	C. PP	100pF 630V		PPコン	
C255-256	VR169100	C. MYLAR	0.39uF 50V		マイラーコン	01
C257	VR325300	C. MYLAR	0.047uF 100V		マイラーコン	01
C258	VR325300	C. MYLAR	0.047uF 100V		マイラーコン	01
C259-260	UA654470	C. MYLAR	0.047uF 50V J		マイラーコン	01
C261	VR325300	C. MYLAR	0.047uF 100V		マイラーコン	01
C262	VR325300	C. MYLAR	0.047uF 100V		マイラーコン	01
C263	VR325300	C. MYLAR	0.047uF 100V		マイラーコン	01
C264-269	UR297100	C. EL	10uF 100V		ケミコン	
C270	UR266470	C. EL	4.7uF 50V		ケミコン	
C271	UR267330	C. EL	33uF 50V		ケミコン	01
C275-278	UA654100	C. MYLAR	0.01uF 50V J		マイラーコン	01
C279	UA654220	C. MYLAR	0.022uF 50V J		マイラーコン	01
C280-281	UA654100	C. MYLAR	0.01uF 50V J		マイラーコン	01
* C283-284	WG001700	C. EL	12000uF 71V		ケミコン	
C286	UR268330	C. EL	330uF 50V		ケミコン	
C287	UR268100	C. EL	100uF 50V		ケミコン	
C288-289	VR324900	C. MYLAR	0.1uF 100V		マイラーコン	01
C290-295	UA654220	C. MYLAR	0.022uF 50V J		マイラーコン	01
C296-297	UA654100	C. MYLAR	0.01uF 50V J		マイラーコン	01
C299	UA654100	C. MYLAR	0.01uF 50V J		マイラーコン	01
C300	UA654100	C. MYLAR	0.01uF 50V J		マイラーコン	01
C301	VR324900	C. MYLAR	0.1uF 100V		マイラーコン	01
C302	VR324900	C. MYLAR	0.1uF 100V		マイラーコン	01
C303-304	UA654220	C. MYLAR	0.022uF 50V J		マイラーコン	01
C305	UA654100	C. MYLAR	0.01uF 50V J		マイラーコン	01
C350-356	UA654100	C. MYLAR	0.01uF 50V J		マイラーコン	01
D207-213	VD631600	DIODE	1SS133,176		ダイオード	01
D214-222	WA180300	DIODE	1SS244		ダイオード	01
D225	VM976300	DIODE. ZENR	HZS242TD 24V		ツェナーダイオード	01
D227	VM976300	DIODE. ZENR	HZS242TD 24V		ツェナーダイオード	01

* New Parts * 新規部品

P.C.B. MAIN

Ref No.	Part No.	Description	Remarks	Markets	部 品 名	Rank
D228	VG443700	DIODE. ZENR	MTZJ33B 33V		ツェナーダイオード	01
D231	VM976300	DIODE. ZENR	HZS242TD 24V		ツェナーダイオード	01
D233	VM976300	DIODE. ZENR	HZS242TD 24V		ツェナーダイオード	01
D235	VM976300	DIODE. ZENR	HZS242TD 24V		ツェナーダイオード	01
D238	VM976300	DIODE. ZENR	HZS242TD 24V		ツェナーダイオード	01
△ D240-243	VS997800	DIODE	1T2		ダイオード	01
△ D246	VZ755200	DIODE. BRG	D15XB20 15A 200V		ダイオードブリッジ	04
D247-253	VD631600	DIODE	1SS133, 176		ダイオード	01
D270-276	VG437500	DIODE. ZENR	MTZJ5.1C 5.1V		ツェナーダイオード	01
G201	V5995800	PLATE. GND			アースプレート	
△ IC201-202	X0515A00	IC	LM61CIZ THERMAL		電源IC	03
PN201-208	V9637500	PIN	L=70 #18		スタイルピン	
△ Q213-214	VK432900	TR	2SD1915F S,T		トランジスタ	01
△ Q215-216	iC224030	TR	2SC2240 GR,BL		トランジスタ	01
△ Q217-219	VK432900	TR	2SD1915F S,T		トランジスタ	01
△ Q220A	iX632610	TR	2SA1837 0,Y		トランジスタ	02
△ Q220C	iX632620	TR	2SC4793 0,Y		トランジスタ	02
△ Q221A	iX632610	TR	2SA1837 0,Y		トランジスタ	02
△ Q221C	iX632620	TR	2SC4793 0,Y		トランジスタ	02
△ Q222A	iX632610	TR	2SA1837 0,Y		トランジスタ	02
△ Q222C	iX632620	TR	2SC4793 0,Y		トランジスタ	02
△ Q223A	iX632610	TR	2SA1837 0,Y		トランジスタ	02
△ Q223C	iX632620	TR	2SC4793 0,Y		トランジスタ	02
△ Q224A	iX632610	TR	2SA1837 0,Y		トランジスタ	02
△ Q224C	iX632620	TR	2SC4793 0,Y		トランジスタ	02
△ Q225A	iX632610	TR	2SA1837 0,Y		トランジスタ	02
△ Q225C	iX632620	TR	2SC4793 0,Y		トランジスタ	02
△ Q226	WD281200	TR. PAIR	A2151/C6011 0,P,Y	JKBGL	ペアトランジスタ	07
△ Q226A	iX606460	TR	2SA1492 0,P,Y	UCRTA	トランジスタ	05
△ Q226C	iX606470	TR	2SC3856 0,P,Y	UCRTA	トランジスタ	05
△ Q227	WD281200	TR. PAIR	A2151/C6011 0,P,Y	JKBGL	ペアトランジスタ	07
△ Q227A	iX606460	TR	2SA1492 0,P,Y	UCRTA	トランジスタ	05
△ Q227C	iX606470	TR	2SC3856 0,P,Y	UCRTA	トランジスタ	05
△ Q228	WD281200	TR. PAIR	A2151/C6011 0,P,Y	JKBGL	ペアトランジスタ	07
△ Q228A	iX606460	TR	2SA1492 0,P,Y	UCRTA	トランジスタ	05
△ Q228C	iX606470	TR	2SC3856 0,P,Y	UCRTA	トランジスタ	05
△ Q229	WD281200	TR. PAIR	A2151/C6011 0,P,Y	JKBGL	ペアトランジスタ	07
△ Q229A	iX606460	TR	2SA1492 0,P,Y	UCRTA	トランジスタ	05
△ Q229C	iX606470	TR	2SC3856 0,P,Y	UCRTA	トランジスタ	05
△ Q230	WD281200	TR. PAIR	A2151/C6011 0,P,Y	JKBGL	ペアトランジスタ	07
△ Q230A	iX606460	TR	2SA1492 0,P,Y	UCRTA	トランジスタ	05
△ Q230C	iX606470	TR	2SC3856 0,P,Y	UCRTA	トランジスタ	05
△ Q231	WD281200	TR. PAIR	A2151/C6011 0,P,Y	JKBGL	ペアトランジスタ	07
△ Q231A	iX606460	TR	2SA1492 0,P,Y	UCRTA	トランジスタ	05
△ Q231C	iX606470	TR	2SC3856 0,P,Y	UCRTA	トランジスタ	05
△ Q232	WD281200	TR. PAIR	A2151/C6011 0,P,Y	JKBGL	ペアトランジスタ	07
△ Q232A	iX606460	TR	2SA1492 0,P,Y	UCRTA	トランジスタ	05
△ Q232C	iX606470	TR	2SC3856 0,P,Y	UCRTA	トランジスタ	05
△ Q233A	iX632610	TR	2SA1837 0,Y		トランジスタ	02
△ Q233C	iX632620	TR	2SC4793 0,Y		トランジスタ	02
Q248-254	iC224030	TR	2SC2240 GR,BL		トランジスタ	01
Q255-256	VP872700	TR	2SC4488 S,T		トランジスタ	01
Q257	iA101510	TR	2SA1015 Y		トランジスタ	01
Q258	VP872700	TR	2SC4488 S,T		トランジスタ	01

* New Parts * 新規部品

P.C.B. MAIN

Ref No.	Part No.	Description	Remarks	Markets	部 品 名	Rank
Q261-262	VP872700	TR	2SC4488 S,T		トランジスタ	01
△ Q263-269	VR325600	TR	2SC2229 O,Y		トランジスタ	01
Q280	VP872700	TR	2SC4488 S,T		トランジスタ	01
△ R201	V3943000	R. MTL. FLM	4.7Ω 1/2W		金属被膜抵抗	01
R202-204	HV753470	R. CAR. FP	4.7Ω 1/4W		不燃化カーボン抵抗	01
R212-213	HV753470	R. CAR. FP	4.7Ω 1/4W		不燃化カーボン抵抗	01
R215-218	HV753470	R. CAR. FP	4.7Ω 1/4W		不燃化カーボン抵抗	01
△ R220	HV753100	R. CAR. FP	1Ω 1/4W		不燃化カーボン抵抗	01
△ R222	HV753100	R. CAR. FP	1Ω 1/4W		不燃化カーボン抵抗	01
R263	V3946100	R. MTL. OXD	2.7KΩ 1/2W		酸化金属被膜抵抗	01
R264	V3945100	R. MTL. OXD	390Ω 1/2W		酸化金属被膜抵抗	01
R265	V3945500	R. MTL. OXD	820Ω 1/2W		酸化金属被膜抵抗	01
△ R266	HV755120	R. CAR. FP	120Ω 1/4W		不燃化カーボン抵抗	01
R267	V3946100	R. MTL. OXD	2.7KΩ 1/2W		酸化金属被膜抵抗	01
R268	V3945100	R. MTL. OXD	390Ω 1/2W		酸化金属被膜抵抗	01
R269	V3945500	R. MTL. OXD	820Ω 1/2W		酸化金属被膜抵抗	01
△ R270	HV755120	R. CAR. FP	120Ω 1/4W		不燃化カーボン抵抗	01
R271	V3946100	R. MTL. OXD	2.7KΩ 1/2W		酸化金属被膜抵抗	01
R272	V3944900	R. MTL. OXD	270Ω 1/2W		酸化金属被膜抵抗	01
R273	V3945600	R. MTL. OXD	1KΩ 1/2W		酸化金属被膜抵抗	01
△ R274	HV755120	R. CAR. FP	120Ω 1/4W		不燃化カーボン抵抗	01
R275	V3946100	R. MTL. OXD	2.7KΩ 1/2W		酸化金属被膜抵抗	01
R276	V3944900	R. MTL. OXD	270Ω 1/2W		酸化金属被膜抵抗	01
R277	V3945600	R. MTL. OXD	1KΩ 1/2W		酸化金属被膜抵抗	01
△ R278	HV755120	R. CAR. FP	120Ω 1/4W		不燃化カーボン抵抗	01
R279	V3946100	R. MTL. OXD	2.7KΩ 1/2W		酸化金属被膜抵抗	01
R280	V3945100	R. MTL. OXD	390Ω 1/2W		酸化金属被膜抵抗	01
R281	V3945500	R. MTL. OXD	820Ω 1/2W		酸化金属被膜抵抗	01
△ R282	HV755120	R. CAR. FP	120Ω 1/4W		不燃化カーボン抵抗	01
R283	V3946100	R. MTL. OXD	2.7KΩ 1/2W		酸化金属被膜抵抗	01
R284	V3945100	R. MTL. OXD	390Ω 1/2W		酸化金属被膜抵抗	01
R285	V3945500	R. MTL. OXD	820Ω 1/2W		酸化金属被膜抵抗	01
△ R286	HV755120	R. CAR. FP	120Ω 1/4W		不燃化カーボン抵抗	01
R287	V3946100	R. MTL. OXD	2.7KΩ 1/2W		酸化金属被膜抵抗	01
R288	V3945100	R. MTL. OXD	390Ω 1/2W		酸化金属被膜抵抗	01
R289	V3945500	R. MTL. OXD	820Ω 1/2W		酸化金属被膜抵抗	01
△ R290	HV755120	R. CAR. FP	120Ω 1/4W		不燃化カーボン抵抗	01
R291-297	V3945600	R. MTL. OXD	1KΩ 1/2W		酸化金属被膜抵抗	01
△ R298-299	HV755220	R. CAR. FP	220Ω 1/4W		不燃化カーボン抵抗	01
△ R300-304	HV755220	R. CAR. FP	220Ω 1/4W		不燃化カーボン抵抗	01
△ R305-318	HV753470	R. CAR. FP	4.7Ω 1/4W		不燃化カーボン抵抗	01
R319-320	V3873200	R. CEMENT	0.22Ω 3W		セメント抵抗	02
R321-322	WB279900	R. CEMENT	RGC55C 0.22+0.22		セメント抵抗	02
R325	V3873200	R. CEMENT	0.22Ω 3W		セメント抵抗	02
R326-327	WB279900	R. CEMENT	RGC55C 0.22+0.22		セメント抵抗	02
R349-355	VP939700	R. MTL. FLM	4.7Ω 1W		金属被膜抵抗	01
R363-365	HV754100	R. CAR. FP	10Ω 1/4W		不燃化カーボン抵抗	01
R367	HV754100	R. CAR. FP	10Ω 1/4W		不燃化カーボン抵抗	01
R371-373	HV754100	R. CAR. FP	10Ω 1/4W		不燃化カーボン抵抗	01
△ R380-382	V3942700	R. MTL. FLM	1Ω 1/2W		金属被膜抵抗	01
R387	HV756100	R. CAR. FP	1KΩ 1/4W		不燃化カーボン抵抗	01
△ R389	HV755100	R. CAR. FP	100Ω 1/4W		不燃化カーボン抵抗	01
△ R400-404	HV754820	R. CAR. FP	82Ω 1/4W		不燃化カーボン抵抗	01
R422	HV754820	R. CAR. FP	82Ω 1/4W		不燃化カーボン抵抗	01

* New Parts * 新規部品

P.C.B. MAIN & P.C.B. POWER

Ref No.	Part No.	Description	Remarks	Markets	部 品 名	Rank
R201-205	V6322600	RELAY	DC DH24D2-0T(M)-SL		リレー 24V	04
R206	WA544800	RELAY	DC G5PA-28		リレー 24V	04
TE201	WD477700	TERM. SP	LTS0810-1019FM	JUCRTA	スピーカーターミナル	06
* TE201	WD477500	TERM. SP	LTS0810-1015FM	KBGL	スピーカーターミナル	
TE202	WD756900	TERM. SP	LTS3210-1004FM	JUCRTA	スピーカーターミナル	04
* TE202	WD757000	TERM. SP	LTS3210-1003FM	KBGL	スピーカーターミナル	
TE203	WD039300	TERM. SP	LOR2411-0001FM	JUCRTA	スピーカターミナル	04
* TE203	WD039400	TERM. SP	LOR2411-0003FM	KBGL	スピーカターミナル	
TE204	WD477700	TERM. SP	LTS0810-1019FM	JUCRTA	スピーカーターミナル	06
* TE204	WD477500	TERM. SP	LTS0810-1015FM	KBGL	スピーカーターミナル	
	VT669300	SCR. BW. HD	3x8-8 MFC2		PWヘッドBタイトネジ	01
* WG076300	P.C.B.	POWER		J	P C B パワー	
* WG076400	P.C.B.	POWER		UC	P C B パワー	
* WG076500	P.C.B.	POWER		R	P C B パワー	
* WG076600	P.C.B.	POWER		T	P C B パワー	
* WG076700	P.C.B.	POWER		K	P C B パワー	
* WG076800	P.C.B.	POWER		A	P C B パワー	
* WG076900	P.C.B.	POWER		B	P C B パワー	
* WG077000	P.C.B.	POWER		G	P C B パワー	
* WG077100	P.C.B.	POWER		L	P C B パワー	
CB2-3	WC050700	CLIP. FUSE	EYF-52BCY	UCG	ヒューズクリップ	01
CB4	VS996100	HOLDER. FUS	EYF64BC	JUCRL	ヒューズクリップ	01
CB4	WC050700	CLIP. FUSE	EYF-52BCY	TKABG	ヒューズクリップ	01
CB6	VS996100	HOLDER. FUS	EYF64BC	JUCRL	ヒューズクリップ	01
CB5	WC050700	CLIP. FUSE	EYF-52BCY	TKABG	ヒューズクリップ	01
CB7	VG879900	CN. BS. PIN	2P		ベースピン	01
* CB8	V9377900	CN. BS. PIN	4P SE VH SERIES	RL	ベース付ポスト	
* CB9	V9377800	CN. BS. PIN	3P SE VH SERIES	RL	ベース付ポスト	
CB10	WC050700	CLIP. FUSE	EYF-52BCY	RL	ヒューズクリップ	01
CB11	WC050700	CLIP. FUSE	EYF-52BCY	RL	ヒューズクリップ	01
* CB12	LB933030	CN. BS. PIN	3P		ベースポスト	01
CB13	LB919090	CN. BS. PIN	9P		ベース付ポスト	02
CB14	VB858400	CN. BS. PIN	5P		ベースピン	01
* CB16	LB918100	CN. BS. PIN	10P		ベース付ポスト	02
CB17	LB918050	CN. BS. PIN	5P		ベース付ポスト	01
CB20-21	VB389900	CN. BS. PIN	3P		ベースピン	01
CB40	VB858700	CN. BS. PIN	8P		ベースピン	01
CB41	V7827600	SOCKET	9P SE TUC SERIES		コネクタースOCKET	
CB42	V7827500	SOCKET	8P SE TUC SERIES		コネクタースOCKET	
CB43	V7827200	SOCKET	5P TE TUC SERIES		コネクタースOCKET	
CB44	VB858300	CN. BS. PIN	4P		コネクタベースポスト	01
CB46	VB858500	CN. BS. PIN	6P		ベースピン	01
CB47	V7827800	SOCKET	11P SE TUC SERIES		コネクタースOCKET	
CB48	V7827100	SOCKET	4P TE TUC SERIES		コネクタースOCKET	
CB324	VB858200	CN. BS. PIN	3P		ベースピン	01
CB325	VB858300	CN. BS. PIN	4P		コネクタベースポスト	01
C1	UR866220	C. EL	2.2uF 50V		ケミコン	01
C2	UR266220	C. EL	2.2uF 50V		ケミコン	
C3	UA654100	C. MYLAR	0.01uF 50V J		マイラーコン	01
C4	WB687100	C. POL. MTL	0.047uF 400V	JUC	メタライズドポリコン	01
* C4	WD054200	C. POL. MTL	0.047uF 630V	R	メタライズドポリコン	

* New Parts * 新規部品

P.C.B. POWER

Ref No.	Part No.	Description	Remarks	Markets	部 品 名	Rank
C4	WC041600	C. PP	0.022uF 630V		TKABGL P P コン	01
C5	UR266100	C. EL	1uF 50V		ケミコン	
C6	UA653470	C. MYLAR	4700pF 50V J		マイラーコン	01
C7	WB696300	C. POL. MTL	0.1uF 400V	JUC	メタライズドポリコン	
* C7	WD257600	C. PP	0.047uF 800V	RTKABGL	P P コン	
△ C8	V6185300	C. CE. SAFTY	0.01uF 275V		規格認定コン	
C9	WE102900	C. PP	0.01uF 100V		P P コン	
C10	UU249330	C. EL	3300uF 25V	JUCTKABGL	ケミコン FW	04
* C10	WDO47300	C. EL	3300uF 50V	R	ケミコン KMQ	
* C16-17	UU23A150	C. EL	15000uF 16V		ケミコン FW	
C18	UR239330	C. EL	3300uF 16V		ケミコン	02
* C19	UU23A150	C. EL	15000uF 16V		ケミコン FW	
C20	UR268100	C. EL	100uF 50V		ケミコン	
C21-22	UR267100	C. EL	10uF 50V		ケミコン	
C23	UR258470	C. EL	470uF 35V		ケミコン	
C24	UR249680	C. EL	6800uF 25V		ケミコン	
C25	UR249330	C. EL	3300uF 25V		ケミコン	
△ C26-29	UR267100	C. EL	10uF 50V		ケミコン	
△ C30-32	US035100	C. CE. CHP	0.1uF 16V B		チップセラコン	01
C33	US035100	C. CE. CHP	0.1uF 16V B	UC	チップセラコン	01
C34-35	UR267470	C. EL	47uF 50V		ケミコン	
C36	UR238100	C. EL	100uF 16V		ケミコン	
C37-38	UR238100	C. EL	100uF 16V		ケミコン	
C39	UR238100	C. EL	100uF 16V		ケミコン	
C40	WE102900	C. PP	0.01uF 100V		P P コン	
△ C41-45	V9415100	C. EL	10uF 16V		ケミコン	01
C46	WE100400	C. PP	47pF 630V	JUC	P P コン	
C46	WE100500	C. PP	100pF 630V	RTKABGL	P P コン	
C47	WE100900	C. PP	220pF 630V		P P コン	
C48	UR267100	C. EL	10uF 50V		ケミコン	
C49	WE100400	C. PP	47pF 630V	JUC	P P コン	
C49	WE100500	C. PP	100pF 630V	RTKABGL	P P コン	
C50	WE100900	C. PP	220pF 630V		P P コン	
C51	UR267100	C. EL	10uF 50V		ケミコン	
C52	WE100400	C. PP	47pF 630V	JUC	P P コン	
C52	WE100500	C. PP	100pF 630V	RTKABGL	P P コン	
C53	WE100900	C. PP	220pF 630V		P P コン	
C54	UR267100	C. EL	10uF 50V		ケミコン	
C55	WE100400	C. PP	47pF 630V	JUC	P P コン	
C55	WE100500	C. PP	100pF 630V	RTKABGL	P P コン	
C56	WE100900	C. PP	220pF 630V		P P コン	
C57	UR267100	C. EL	10uF 50V		ケミコン	
C58	WE100400	C. PP	47pF 630V	JUC	P P コン	
C58	WE100500	C. PP	100pF 630V	RTKABGL	P P コン	
C59	WE100900	C. PP	220pF 630V		P P コン	
C60	UR267100	C. EL	10uF 50V		ケミコン	
C61-62	UU268100	C. EL	100uF 50V		ケミコン	01
C63-64	UR267470	C. EL	47uF 50V		ケミコン	
C65	UU268100	C. EL	100uF 50V		ケミコン	01
C66-69	WE100100	C. PP	15pF 630V		P P コン	
C70	WE100100	C. PP	15pF 630V		P P コン	
C71-75	WE101700	C. PP	1000pF 100V		P P コン	
C76	UR266470	C. EL	4.7uF 50V		ケミコン	
C77	UR267470	C. EL	47uF 50V		ケミコン	

* New Parts * 新規部品

P.C.B. POWER

Ref No.	Part No.	Description	Remarks	Markets	部 品 名	Rank
C78	UR218220	C.EL	220uF 6.3V		ケミコン	
C79	UR237100	C.EL	10uF 16V		ケミコン	
C80	UR237100	C.EL	10uF 16V		ケミコン	
C81	WE100400	C.PP	47pF 630V		PPコン	
C82	UA652220	C.MYLAR	220pF 50V J		マイラーコン	01
C83	UR267100	C.EL	10uF 50V		ケミコン	
C84	WE100400	C.PP	47pF 630V		PPコン	
C85	UA652220	C.MYLAR	220pF 50V J		マイラーコン	01
C86	UR267100	C.EL	10uF 50V		ケミコン	
C87	UR297220	C.EL	22uF 100V	JUC	ケミコン	01
C87	UR297470	C.EL	47uF 100V	RTKABGL	ケミコン	
C88	UR297220	C.EL	22uF 100V		ケミコン	
C89	UR267470	C.EL	47uF 50V		ケミコン	
C90	UR267470	C.EL	47uF 50V		ケミコン	
C91-92	UA653100	C.MYLAR	1000pF 50V J		マイラーコン	03
C93-94	WE100100	C.PP	15pF 630V		PPコン	
C95	WE100900	C.PP	220pF 630V		PPコン	
C96	UU238100	C.EL	100uF 16V		ケミコン	
C98	UR267470	C.EL	47uF 50V		ケミコン	
C99	UR297220	C.EL	22uF 100V		ケミコン	
C100	UR297220	C.EL	22uF 100V		ケミコン	
C101	UR267470	C.EL	47uF 50V	UC	ケミコン	
C102	US035100	C.CE.CHP	0.1uF 16V B		チップセラコン	01
C103	US035100	C.CE.CHP	0.1uF 16V B	UC	チップセラコン	01
* C104-106	UU23A150	C.EL	15000uF 16V		ケミコン FW	
C107	UR247100	C.EL	10uF 25V		ケミコン	
C108	UR218470	C.EL	470uF 6.3V	UC	ケミコン	
C111	US035100	C.CE.CHP	0.1uF 16V B		チップセラコン	01
C112-114	US065100	C.CE.CHP	0.1uF 50V B		チップセラコン	
C210	UR297470	C.EL	47uF 100V		ケミコン	01
C369-371	US035100	C.CE.CHP	0.1uF 16V B		チップセラコン	01
C372	UR267470	C.EL	47uF 50V		ケミコン	
C495	UR267470	C.EL	47uF 50V		ケミコン	
C499	UU266220	C.EL	2.2uF 50V		ケミコン FW	01
C500	UR267470	C.EL	47uF 50V		ケミコン	
C501	UU266100	C.EL	1uF 50V		ケミコン	01
D1	VD631600	DIODE	1SS133, 176		ダイオード	01
D2	VD631600	DIODE	1SS133, 176		ダイオード	01
D3	VD631600	DIODE	1SS133, 176		ダイオード	01
D4	VD631600	DIODE	1SS133, 176		ダイオード	01
* D5	WA631200	DIODE.ZENR	HZS3B1TD 3.0V TP		ツェナーダイオード	
D6	VG438300	DIODE.ZENR	MTZJ6.8B 6.8V		ツェナーダイオード	01
D7	VG439500	DIODE.ZENR	MTZJ10B 10V		ツェナーダイオード	01
D8	VD631600	DIODE	1SS133, 176		ダイオード	01
D9	VG438700	DIODE.ZENR	MTZJ7.5C 7.5V		ツェナーダイオード	01
⚠ D10	V4756800	DIODE	S1NB60 1.0A 600V		D i スタック	01
⚠ D11	VR253700	DIODE.BRG	S1NB20 1A 200V		D i ブリッジ X 4	02
⚠ D12-14	V6855600	DIODE.BRG	D4SBS4-4101 4A		ダイオードブリッジ	03
⚠ D15	V4269600	DIODE.BRG	D2SBA20 1.5A 200V		ダイオードブリッジ	
D16	VG440400	DIODE.ZENR	MTZJ13A 13V		ツェナーダイオード	01
D19	VU993400	DIODE.ZENR	MA8062-M 6.2V		ツェナーダイオード	01
D20	VS997800	DIODE	1T2		ダイオード	01
D21	VS858600	DIODE.ZENR	HZS24-1 24V		ツェナーダイオード	01
D22-23	VU996600	DIODE.ZENR	MA8130-M 13.0V		ツェナーダイオード	01

* New Parts * 新規部品

P.C.B. POWER

Ref No.	Part No.	Description	Remarks	Markets	部 品 名	Rank
D24	VU991700	DIODE. ZENR	MA8043-L 4.1V		ツェナーダイオード	01
D28	V2376600	DIODE. SHOT	RB500V-40	UC	ショットキーダイオード	01
D30	VT332900	DIODE	1SS355		ダイオード	01
D31	VT332900	DIODE	1SS355	UC	ダイオード	01
D40-42	VD631600	DIODE	1SS133,176		ダイオード	01
D43-45	WA180300	DIODE	1SS244		ダイオード	01
D46	VG437200	DIODE. ZENR	MTZJ4.7C 4.7V		ツェナーダイオード	01
D47-49	WA180300	DIODE	1SS244		ダイオード	01
D50-54	WA180300	DIODE	1SS244		ダイオード	01
D56	VG437400	DIODE. ZENR	MTZJ5.1B 5.1V		ツェナーダイオード	01
D323	VT332900	DIODE	1SS355		ダイオード	01
△ F1	KB001390	FUSE	10A 250V	JUCRL	ヒューズ	03
△ F1	KB003250	FUSE	TL6. 3A	TKABG	ヒューズ	01
△ F2	VS823400	FUSE	10A 125V	UC	ヒューズ	01
△ F2	VT942900	FUSE	T2. 5A 250V	G	ヒューズ	01
△ F3	KB003250	FUSE	TL6. 3A	RL	ヒューズ	01
△ IC1-2	V8100500	PHOT. CPL	TLP421 GR		フォトカプラ	01
△ IC3	iG001180	IC	TC4013BP FF		ロジックIC	05
△ IC4	XU814A00	IC	PQ05RD11 +5V 1.0A		電源IC	03
△ IC5-6	X2530A00	IC	PQ05RD21 +5V 2.0A		電源IC	03
△ IC7	XU814A00	IC	PQ05RD11 +5V 1.0A	UC	電源IC	03
* △ IC317-318	X7218A00	IC	PQ30RV21		電源IC	
△ IC319	X2530A00	IC	PQ05RD21 +5V 2.0A		電源IC	03
△ IC320	XE436A00	IC	NJM79M05FA		IC	03
PN1	V9637500	PIN	L=70 #18		スタイルピン	
PN40	V9637500	PIN	L=70 #18		スタイルピン	
PN42-47	V9637500	PIN	L=70 #18		スタイルピン	
PN303	V9637500	PIN	L=70 #18		スタイルピン	
Q1	VV912300	TR. DGT	DTC144ESA-TP		デジタルトランジスタ	
Q2	iC181510	TR	2SC1815 Y		トランジスタ	01
Q3	iC181510	TR	2SC1815 Y		トランジスタ	01
Q4	iC181510	TR	2SC1815 Y		トランジスタ	01
Q5	iC181510	TR	2SC1815 Y		トランジスタ	01
△ Q6	WC741200	FET	2SK3850		FET	
Q7	iE102620	FET	2SK246 Y		FET	01
* △ Q8	WF691400	TR	2SD2014		トランジスタ	
* Q9	VR043100	FET	2SK208 Y		チップFET	01
* Q10-12	VR043100	FET	2SK208 Y		チップFET	01
* △ Q13-14	WF691400	TR	2SD2014		トランジスタ	
* △ Q15	WF691300	TR	2SB1257		トランジスタ	
* △ Q16	WF691400	TR	2SD2014		トランジスタ	
Q17	VV556500	TR	2SA1037K Q,R,S		トランジスタ	01
Q18	VV556500	TR	2SA1037K Q,R,S	UC	トランジスタ	01
Q20	iC181510	TR	2SC1815 Y		トランジスタ	01
△ Q21	VC141900	TR	2SB941 P,Q		トランジスタ	04
Q40-49	iC224030	TR	2SC2240 GR,BL		トランジスタ	01
Q50-54	V3966800	TR	2SA949 O,Y		トランジスタ	02
Q55	iA097030	TR	2SA970 GR,BL		トランジスタ	01
Q56-58	iC224030	TR	2SC2240 GR,BL		トランジスタ	01
Q59	iA097030	TR	2SA970 GR,BL		トランジスタ	01
Q60-61	iC224030	TR	2SC2240 GR,BL		トランジスタ	01
△ Q62	VC938500	TR	2SC3852		トランジスタ	02
△ Q63	VC614000	TR	2SB1274 Q,R,S		トランジスタ	02
Q64-65	V3966800	TR	2SA949 O,Y		トランジスタ	02

* New Parts * 新規部品

P.C.B. POWER

Ref No.	Part No.	Description	Remarks	Markets	部 品 名	Rank
Q66	iA097030	TR	2SA970 GR,BL		トランジスタ	01
Q67-68	iC224030	TR	2SC2240 GR,BL		トランジスタ	01
Q319	WV655000	TR. DGT	DTA114EKA		デジタルトランジスタ	01
Q320	WV556400	TR	2SC2412K Q,R,S		トランジスタ	01
△ Q321	VP872700	TR	2SC4488 S,T		トランジスタ	01
Q323	WV655300	TR. DGT	DTA144EKA		デジタルトランジスタ	01
R9	V6730000	R. CAR.	2.2MΩ 1/2W	UC	放電抵抗	01
R13	VU224000	R. MTL. FLM	0.22Ω 1W		金属被膜抵抗	01
R19		R. CHP	47KΩ 1/16W J	UC	チップ抵抗	
△ R20	HV754100	R. CAR. FP	10Ω 1/4W		不燃化カーボン抵抗	01
R23	HV756330	R. CAR. FP	3.3KΩ 1/4W		不燃化カーボン抵抗	01
R24	HV756470	R. CAR. FP	4.7KΩ 1/4W		不燃化カーボン抵抗	01
R25	HV755100	R. CAR. FP	100Ω 1/4W		不燃化カーボン抵抗	01
R26	VP939800	R. MTL. OXD	10Ω 1W		酸化金属被膜抵抗	01
R31	HV753470	R. CAR. FP	4.7Ω 1/4W		不燃化カーボン抵抗	01
R32	HV755100	R. CAR. FP	100Ω 1/4W		不燃化カーボン抵抗	01
△ R39	HV753470	R. CAR. FP	4.7Ω 1/4W		不燃化カーボン抵抗	01
R40	HF353220	R. CAR	2.2Ω 1/2W		カーボン抵抗	
R41-42	HF358100	R. CAR	100KΩ 1/2W		カーボン抵抗	
R45	HF358100	R. CAR	100KΩ 1/2W		カーボン抵抗	
R51-52	HF355220	R. CAR	220Ω 1/2W		カーボン抵抗	
R55	HF355220	R. CAR	220Ω 1/2W		カーボン抵抗	
R61	HF357330	R. CAR	33KΩ 1/2W		カーボン抵抗	
R62-63	HF356220	R. CAR	2.2KΩ 1/2W		カーボン抵抗	
R67	HF356220	R. CAR	2.2KΩ 1/2W		カーボン抵抗	
R68	HF357330	R. CAR	33KΩ 1/2W		カーボン抵抗	
R70	HF357330	R. CAR	33KΩ 1/2W		カーボン抵抗	
R76-77	HF356120	R. CAR	1.2KΩ 1/2W		カーボン抵抗	
R80	HF356120	R. CAR	1.2KΩ 1/2W		カーボン抵抗	
R81-82	HF357330	R. CAR	33KΩ 1/2W		カーボン抵抗	
R85	HF357330	R. CAR	33KΩ 1/2W		カーボン抵抗	
R86-87	HF355330	R. CAR	330Ω 1/2W		カーボン抵抗	
R90	HF355330	R. CAR	330Ω 1/2W		カーボン抵抗	
R91	V3733100	R. MTL. OXD	39Ω 1W		酸化金属被膜抵抗	
R92	HF355470	R. CAR	470Ω 1/2W		カーボン抵抗	
R93	V3733100	R. MTL. OXD	39Ω 1W		酸化金属被膜抵抗	
R94	HF355470	R. CAR	470Ω 1/2W		カーボン抵抗	
R95-96	HV754390	R. CAR. FP	39Ω 1/4W		不燃化カーボン抵抗	01
R97	V3733100	R. MTL. OXD	39Ω 1W		酸化金属被膜抵抗	
R98	HF355470	R. CAR	470Ω 1/2W		カーボン抵抗	
R101-102	HF357470	R. CAR	47KΩ 1/2W		カーボン抵抗	
R105	HF357470	R. CAR	47KΩ 1/2W		カーボン抵抗	
R138	HF353220	R. CAR	2.2Ω 1/2W		カーボン抵抗	
R145-146	HV754390	R. CAR. FP	39Ω 1/4W		不燃化カーボン抵抗	01
R153	HV756470	R. CAR. FP	4.7KΩ 1/4W		不燃化カーボン抵抗	01
R154	HV756680	R. CAR. FP	6.8KΩ 1/4W		不燃化カーボン抵抗	01
R155	HV756820	R. CAR. FP	8.2KΩ 1/4W		不燃化カーボン抵抗	01
△ R160-162	HV753470	R. CAR. FP	4.7Ω 1/4W		不燃化カーボン抵抗	01
R164	HV757100	R. CAR. FP	10KΩ 1/4W		不燃化カーボン抵抗	01
△ R166	HV754100	R. CAR. FP	10Ω 1/4W		不燃化カーボン抵抗	01
△ R168	HV754100	R. CAR. FP	10Ω 1/4W		不燃化カーボン抵抗	01
R169		R. CHP	1KΩ 1/16W J	UC	チップ抵抗	
△ R170-173	HV755100	R. CAR. FP	100Ω 1/4W		不燃化カーボン抵抗	01
R180		R. CHP	10KΩ 1/16W J	UC	チップ抵抗	

* New Parts * 新規部品

P.C.B. POWER & P.C.B. INPUT

Ref No.	Part No.	Description	Remarks	Markets	部 品 名	Rank
	R181	R. CHP	100K Ω 1/16W J		チップ抵抗	
△	R499	VP939500 R. MTL. FLM	1 Ω 1W		金属被膜抵抗	01
△	R500-501	VP939500 R. MTL. FLM	1 Ω 1W		金属被膜抵抗	01
△	RY1	V9366900 RELAY	DLS9D1-0(M)0.25W		リレー 9V TV-8	05
	ST1-4	WG095100 SCR. TERM	(CUT) CU		ネジ端子	
	ST301	WA246200 SCR. TERM	3.5		スクリューターミナル	
* △	SW1	WB493700 VOLT. SELCT	R8140246	RL	電圧切替器	
* △	T1	X7032A00 TRANS. PWR		J	電源トランス	
* △	T1	X7033A00 TRANS. PWR		UC	電源トランス	
* △	T1	X7034A00 TRANS. PWR		RL	電源トランス	
* △	T1	X7035A00 TRANS. PWR		TKABG	電源トランス	
	TE1	VU543100 OUTLET. AC	2P	JUC	ACアウトレット	03
	TE1	V5867400 OUTLET. AC	2P AC-182-GB-11V	RT	ACアウトレット 2P	
	TE1	VT915000 OUTLET. AC	1P	A	ACアウトレット	06
	TE1	VU543300 OUTLET. AC	1P	B	ACアウトレット	05
	TE1	VU543400 OUTLET. AC	2P	GL	ACアウトレット	05
	TE2	WB782600 AC INLET	R-30190(26)		ACインレット 2P	
* △	TH1	VV458400 POLY SW	RUEF600 6.00A 30V		ポリスイッチ	
		VT669300 SCR. BW. HD	3x8-8 MFC2		PWヘッドBタイトネジ	01
* △		WG082300 P. C. B.	INPUT	JRTKABGL	P C B インプット	
* △		WG265600 P. C. B.	INPUT	UC	P C B インプット	
* △	CB301	VU443800 CN	JE 15P SE		JEコネクタープラグ	01
	CB302	V7828200 SOCKET	15P TE TUC SERIES		コネクターソケット	
	CB303-304	V8875300 CN	JE 13P SE		JEコネクタープラグ	01
	CB305	V7826500 CN	15P TE TUC SERIES		コネクタープラグ	01
* △	CB306	V8809800 CN	JE 9P SE		JEコネクタープラグ	01
	CB307	VB858400 CN. BS. PIN	5P	UC	ベースピン	01
	CB308	V7826500 CN	15P TE TUC SERIES		コネクタープラグ	01
	CB309	V7828200 SOCKET	15P TE TUC SERIES		コネクターソケット	
	CB315-316	V7827000 CN	20P TE TUC SERIES		コネクタープラグ	01
	CB317	V7825600 CN	6P TE TUC SERIES		コネクタープラグ	
	CB332	VB390800 CN. BS. PIN	12P		コネクタベースポスト	01
	CB600	VP798200 CN. BS. PIN	24P		FFCコネクター	01
	C301-302	US135100 C. CE. CHP	0.1uF 16V		チップセラコン	01
	C303-306	US062220 C. CE. CHP	220pF 50V B		チップセラコン	01
	C307-308	US062100 C. CE. CHP	100pF 50V B		チップセラコン	01
	C309-310	US062220 C. CE. CHP	220pF 50V B		チップセラコン	01
	C311-312	US062100 C. CE. CHP	100pF 50V B		チップセラコン	01
	C313-314	UA652220 C. MYLAR	220pF 50V J		マイラーコン	01
	C315-316	US062220 C. CE. CHP	220pF 50V B		チップセラコン	01
	C317-320	UA652220 C. MYLAR	220pF 50V J		マイラーコン	01
	C321	UA652470 C. MYLAR	470pF 50V J		マイラーコン	01
	C322	UA652220 C. MYLAR	220pF 50V J		マイラーコン	01
	C323-328	UR266220 C. EL	2.2uF 50V		ケミコン	
	C329-330	UR218220 C. EL	220uF 6.3V		ケミコン	
	C331-332	UA654390 C. MYLAR	0.039uF 50V J		マイラーコン	01
	C333-334	UA654110 C. MYLAR	0.011uF 50V J		マイラーコン	01
	C335-342	UR237100 C. EL	10uF 16V		ケミコン	
	C343-344	UR237470 C. EL	47uF 16V		ケミコン	
	C345-348	UA653100 C. MYLAR	1000pF 50V J		マイラーコン	03
	C349-350	UR267470 C. EL	47uF 50V		ケミコン	

* New Parts * 新規部品

P.C.B. INPUT

Ref No.	Part No.	Description	Remarks	Markets	部 品 名	Rank
C351-354	UR237100	C.EL	10uF	16V	ケミコン	
C355-356	UR267470	C.EL	47uF	50V	ケミコン	
C357-358	UR266470	C.EL	4.7uF	50V	ケミコン	
C359-360	UT952100	C.PP	100pF	100V	PPコン	
C361-362	UR267470	C.EL	47uF	50V	ケミコン	
C363	US135100	C.CE.CHP	0.1uF	16V	チップセラコン	01
C364-365	UR266470	C.EL	4.7uF	50V	ケミコン	
C366	US135100	C.CE.CHP	0.1uF	16V	チップセラコン	01
C367-368	UR237100	C.EL	10uF	16V	ケミコン	
C373-376	US062470	C.CE.CHP	470pF	50V B	チップセラコン	01
C377-380	US062220	C.CE.CHP	220pF	50V B	チップセラコン	01
C381-382	US062100	C.CE.CHP	100pF	50V B	チップセラコン	01
C383-384	US062220	C.CE.CHP	220pF	50V B	チップセラコン	01
C385-386	US062100	C.CE.CHP	100pF	50V B	チップセラコン	01
C387-388	UA652220	C.MYLAR	220pF	50V J	マイラーコン	01
C389-390	US062220	C.CE.CHP	220pF	50V B	チップセラコン	01
C391-394	UR266470	C.EL	4.7uF	50V	ケミコン	
C395	UR237100	C.EL	10uF	16V	ケミコン	
C396	US135100	C.CE.CHP	0.1uF	16V	チップセラコン	01
C397	UR237100	C.EL	10uF	16V	ケミコン	
C398-399	UR237470	C.EL	47uF	16V	ケミコン	
C400-401	UR237220	C.EL	22uF	16V	ケミコン	
C403	UR237470	C.EL	47uF	16V	ケミコン	
C404	US135100	C.CE.CHP	0.1uF	16V	チップセラコン	01
C405-406	US034680	C.CE.CHP	0.068uF	16V K	チップセラコン	01
C407-414	VR168300	C.MYLAR	0.1uF	50V	マイラーコン	01
C415-418	UA653270	C.MYLAR	2700pF	50V J	マイラーコン	01
C419	US135100	C.CE.CHP	0.1uF	16V	チップセラコン	01
C420-421	UR267470	C.EL	47uF	50V	ケミコン	
C422-425	UR266470	C.EL	4.7uF	50V	ケミコン	
C426-429	US135100	C.CE.CHP	0.1uF	16V	チップセラコン	01
C430	UR237470	C.EL	47uF	16V	ケミコン	
C431	US135100	C.CE.CHP	0.1uF	16V	チップセラコン	01
C432-434	UR237100	C.EL	10uF	16V	ケミコン	
C435	UR237470	C.EL	47uF	16V	ケミコン	
C436	UR237100	C.EL	10uF	16V	ケミコン	
C437	US135100	C.CE.CHP	0.1uF	16V	チップセラコン	01
C438-439	UR237100	C.EL	10uF	16V	ケミコン	
C442	US063100	C.CE.CHP	1000pF	50V B	チップセラコン	01
C443-444	US135100	C.CE.CHP	0.1uF	16V	チップセラコン	01
C447	US063100	C.CE.CHP	1000pF	50V B	チップセラコン	01
C448-451	UA652470	C.MYLAR	470pF	50V J	マイラーコン	01
C452	VE326800	C.MYLAR	0.47uF	50V	マイラーコン	01
C453-455	UA652470	C.MYLAR	470pF	50V J	マイラーコン	01
C456	US063100	C.CE.CHP	1000pF	50V B	チップセラコン	01
C461	UR218100	C.EL	100uF	6.3V	ケミコン	
C600-602	US064100	C.CE.CHP	0.01uF	50V B	チップセラコン	01
C603	US135100	C.CE.CHP	0.1uF	16V	チップセラコン	01
C604	UM388100	C.EL	100uF	10V	ケミコン	01
C605-606	US064100	C.CE.CHP	0.01uF	50V B	チップセラコン	01
C607	US135100	C.CE.CHP	0.1uF	16V	チップセラコン	01
C608	UR218330	C.EL	330uF	6.3V	ケミコン	
C609-610	US062100	C.CE.CHP	100pF	50V B	チップセラコン	01
C611	UR218330	C.EL	330uF	6.3V	ケミコン	

* New Parts * 新規部品

P.C.B. INPUT

Ref No.	Part No.	Description	Remarks	Markets	部 品 名	Rank
C612	US135100	C. CE. CHP	0.1uF 16V		チップセラコン	01
C614	US062100	C. CE. CHP	100pF 50V B		チップセラコン	01
C615-616	US064100	C. CE. CHP	0.01uF 50V B		チップセラコン	01
C617	US135100	C. CE. CHP	0.1uF 16V		チップセラコン	01
C627	UR267470	C. EL	47uF 50V		ケミコン	
D301-302	VT332900	DIODE	1SS355		ダイオード	01
D305	VT332900	DIODE	1SS355		ダイオード	01
D307-308	VT332900	DIODE	1SS355		ダイオード	01
D309	V2598200	LED	SIR-505ST		LED	
D311-312	VT332900	DIODE	1SS355		ダイオード	01
D313-314	VU992100	DIODE. ZENR	MA8047-L 4.6V		ツェナーダイオード	
* D600-601	VU171600	DIODE. ZENR	UDZS3.9BTE-17 3.9V		ツェナーダイオード	01
D608	VT332900	DIODE	1SS355		ダイオード	01
D611-616	VT332900	DIODE	1SS355		ダイオード	01
IC301	X5045A00	IC	NJU7312AM		アナログIC	
IC302	X5043A00	IC	NJU7313AM		アナログIC	
IC303	X3547A00	IC	BD3841FS		IC	06
IC304-308	X3505A00	IC	NJM2068MD-TE2		アンプIC SOP	02
IC309	X3547A00	IC	BD3841FS		IC	06
* IC310-311	X5574A00	IC	YAC526-EZE2		IC アナログ	
* IC312-313	X6878A00	IC	LC75348M		IC アナログ	
IC600-601	X6386A00	IC	M66003-0131FP		IC	07
* JK301	WD195900	JACK. MNI	2P		ミニ ジャック	
* JK302-303	V9435700	JACK. MNI	MSJ-035-12APC		モノラル ミニジャック	
PJ301-302	VV306900	JACK. PIN	4P		ピンジャック	02
PJ303	V5478700	JACK. PIN	4P RJ-1073F-09		ピンジャック	
* PJ304	V5478900	JACK. PIN	RJ-1074-84-0353A		ピンジャック 6P	
PJ305-307	VV325400	JACK. PIN	6P		ピンジャック	05
PJ308	W306900	JACK. PIN	4P		ピンジャック	02
PJ309	V5479100	JACK. PIN	4P RJ-1073-39-0351		ピンジャック	03
PN301	V9637500	PIN	L=70 #18		スタイルピン	
PN600	V9637500	PIN	L=70 #18		スタイルピン	
PN602	V9637500	PIN	L=70 #18		スタイルピン	
Q301-308	VZ725900	TR	2SD1938F S,T		トランジスタ	
Q309	VP872600	TR	2SA1708 S,T		トランジスタ	01
Q310	VV655700	TR. DGT	DTC144EKA		デジタルトランジスタ	01
Q311	VP872600	TR	2SA1708 S,T		トランジスタ	01
Q312	VV655700	TR. DGT	DTC144EKA		デジタルトランジスタ	01
Q600-608	VV556400	TR	2SC2412K Q,R,S		トランジスタ	01
Q609	VV655400	TR. DGT	DTC114EKA		デジタルトランジスタ	01
R365-366	HV755100	R. CAR. FP	100Ω 1/4W		不燃化カーボン抵抗	01
R375-376	VP939700	R. MTL. FLM	4.7Ω 1W		金属被膜抵抗	01
R387-390	HF355470	R. CAR	470Ω 1/2W		カーボン抵抗	
R444	VP939700	R. MTL. FLM	4.7Ω 1W		金属被膜抵抗	01
R450	VP939700	R. MTL. FLM	4.7Ω 1W		金属被膜抵抗	01
R467-474	HF354470	R. CAR	47Ω 1/2W		カーボン抵抗	
R477-478	HF354270	R. CAR	27Ω 1/2W J		カーボン抵抗	
R600-601	HL005100	R. MTL. OXD	100Ω 1/2W		酸化金属被膜抵抗	
ST301-302	V4040500	SCR. TERM	M3		スクリュー/ターミナル	01
SW600-615	V4757100	SW. TACT	EVQ11A		タクトSW	01
U301	V8210200	L. DTCT	GP1UD271XK		リモコン受光ユニット	03
U600	V8210200	L. DTCT	GP1UD271XK		リモコン受光ユニット	03
* V600	WF875800	FL. DSPLY	HNA-16ML10T		蛍光表示管	
	V6007000	SHEET			シート/FL	03

* New Parts * 新規部品

P.C.B. INPUT & P.C.B. A-VIDEO

Ref No.	Part No.	Description	Remarks	Markets	部 品 名	Rank
	V3747400 WF649700	SPACER. FL SUPRT	6x18 t=4		スペーサ/FL サポート/FL	01
*						
*	WG080900	P.C.B.	A-VIDEO	J	P C B A-V I D E O	
*	WG081000	P.C.B.	A-VIDEO	UC	P C B A-V I D E O	
*	WG081100	P.C.B.	A-VIDEO	RK	P C B A-V I D E O	
*	WG081200	P.C.B.	A-VIDEO	TABGL	P C B A-V I D E O	
CB601	V7827800	SOCKET	11P SE TUC SERIES		コネクタソケット	
CB602	VQ047800	CN. BS. PIN	27P		FFCコネクタ	02
CB603	V7828700	SOCKET	20P SE TUC SERIES		コネクタソケット	01
CB701	V7828100	SOCKET	14P TE TUC SERIES		コネクタソケット	
CB703	VQ045600	CN. BS. PIN	27P SE		FFCコネクタ	03
CB704	V7827300	SOCKET	6P TE TUC SERIES		コネクタソケット	
0611-613	US060800	C. CE. CHP	8pF 50V B		チップセラコン	01
0621-632	US064100	C. CE. CHP	0.01uF 50V B	J	チップセラコン	01
0633-635	US060800	C. CE. CHP	8pF 50V B	J	チップセラコン	01
0641	US135100	C. CE. CHP	0.1uF 16V		チップセラコン	01
0642	UR237470	C. EL	47uF 16V		ケミコン	
0643	US135100	C. CE. CHP	0.1uF 16V		チップセラコン	01
0644	UR237470	C. EL	47uF 16V		ケミコン	
0645	US135100	C. CE. CHP	0.1uF 16V		チップセラコン	01
0646	UR237470	C. EL	47uF 16V		ケミコン	
0647	US135100	C. CE. CHP	0.1uF 16V		チップセラコン	01
0648	UR237470	C. EL	47uF 16V		ケミコン	
0649	US135100	C. CE. CHP	0.1uF 16V		チップセラコン	01
0650	UR237470	C. EL	47uF 16V		ケミコン	
0651	US135100	C. CE. CHP	0.1uF 16V		チップセラコン	01
0652	UR237470	C. EL	47uF 16V		ケミコン	
0653	US135100	C. CE. CHP	0.1uF 16V		チップセラコン	01
0654	UR237470	C. EL	47uF 16V		ケミコン	
0655	US135100	C. CE. CHP	0.1uF 16V		チップセラコン	01
0656	UR237470	C. EL	47uF 16V		ケミコン	
0657	US135100	C. CE. CHP	0.1uF 16V		チップセラコン	01
0658	UR237470	C. EL	47uF 16V		ケミコン	
0659	US135100	C. CE. CHP	0.1uF 16V		チップセラコン	01
0660	UR237470	C. EL	47uF 16V		ケミコン	
0661	US135100	C. CE. CHP	0.1uF 16V		チップセラコン	01
0662-663	UR237470	C. EL	47uF 16V		ケミコン	
0664-665	US135100	C. CE. CHP	0.1uF 16V		チップセラコン	01
0666-667	UR237470	C. EL	47uF 16V		ケミコン	
0668-669	US135100	C. CE. CHP	0.1uF 16V		チップセラコン	01
0670	UR237470	C. EL	47uF 16V		ケミコン	
0672-673	US135100	C. CE. CHP	0.1uF 16V		チップセラコン	01
0674	UR237470	C. EL	47uF 16V		ケミコン	
0676	US135100	C. CE. CHP	0.1uF 16V		チップセラコン	01
0677	UR218330	C. EL	330uF 6.3V		ケミコン	
0678	US135100	C. CE. CHP	0.1uF 16V		チップセラコン	01
* 0679	UR238330	C. EL	330uF 16V		ケミコン	
0680	US135100	C. CE. CHP	0.1uF 16V		チップセラコン	01
0681	UR218330	C. EL	330uF 6.3V		ケミコン	
0682	US135100	C. CE. CHP	0.1uF 16V		チップセラコン	01
0683	UR266100	C. EL	1uF 50V		ケミコン	

* New Parts * 新規部品

P.C.B. A-VIDEO

Ref No.	Part No.	Description	Remarks	Markets	部 品 名	Rank	
C684-685	US135100	C. CE. CHP	0.1uF 16V		J	チップセラコン	01
C686	US135100	C. CE. CHP	0.1uF 16V			チップセラコン	01
C687-691	UR266100	C. EL	1uF 50V			ケミコン	
C692	US135100	C. CE. CHP	0.1uF 16V			チップセラコン	01
C693	UR238470	C. EL	470uF 16V			ケミコン	
C694	US135100	C. CE. CHP	0.1uF 16V			チップセラコン	01
C695	US064100	C. CE. CHP	0.01uF 50V B			チップセラコン	01
C696	UR266220	C. EL	2.2uF 50V			ケミコン	
C697	US135100	C. CE. CHP	0.1uF 16V			チップセラコン	01
C698	UR238100	C. EL	100uF 16V			ケミコン	
C699	US135100	C. CE. CHP	0.1uF 16V			チップセラコン	01
C701-705	US135100	C. CE. CHP	0.1uF 16V		JUC	チップセラコン	01
C706-708	US061470	C. CE. CHP	47pF 50V B			チップセラコン	01
C709	US135100	C. CE. CHP	0.1uF 16V			チップセラコン	01
C710-712	US061470	C. CE. CHP	47pF 50V B			チップセラコン	01
C713	US135100	C. CE. CHP	0.1uF 16V			チップセラコン	01
C714-716	US062100	C. CE. CHP	100pF 50V B			チップセラコン	01
C718	US135100	C. CE. CHP	0.1uF 16V			チップセラコン	01
C742-743	UR237470	C. EL	47uF 16V			ケミコン	
C745-746	UR237470	C. EL	47uF 16V			ケミコン	
C748-749	UR237470	C. EL	47uF 16V			ケミコン	
C752-754	US135100	C. CE. CHP	0.1uF 16V			チップセラコン	01
C755	UR218220	C. EL	220uF 6.3V			ケミコン	
C757	UR218220	C. EL	220uF 6.3V			ケミコン	
C759-760	UR218100	C. EL	100uF 6.3V			ケミコン	
C761-762	US135100	C. CE. CHP	0.1uF 16V			チップセラコン	01
C763	UR218220	C. EL	220uF 6.3V			ケミコン	
C764-765	US135100	C. CE. CHP	0.1uF 16V			チップセラコン	01
C766	UR218220	C. EL	220uF 6.3V			ケミコン	
C771-772	UR266470	C. EL	4.7uF 50V			ケミコン	
C774-775	US135100	C. CE. CHP	0.1uF 16V			チップセラコン	01
C776	UR237100	C. EL	10uF 16V			ケミコン	
C777	UR266470	C. EL	4.7uF 50V			ケミコン	
C778	UR218100	C. EL	100uF 6.3V			ケミコン	
C779	UR218330	C. EL	330uF 6.3V			ケミコン	
C780	UR218100	C. EL	100uF 6.3V			ケミコン	
C781-782	US060300	C. CE. CHP	3pF 50V B		JUCRK	チップセラコン	01
C783-784	US061240	C. CE. CHP	24pF 50V B			チップセラコン	01
C785	US060300	C. CE. CHP	3pF 50V B		JUCRK	チップセラコン	01
C786	US135100	C. CE. CHP	0.1uF 16V			チップセラコン	01
C787	UR218100	C. EL	100uF 6.3V			ケミコン	
C788-789	UR266100	C. EL	1uF 50V			ケミコン	
C791	US063120	C. CE. CHP	1200pF 50V B			チップセラコン	01
C792	US062470	C. CE. CHP	470pF 50V B			チップセラコン	01
C799	US135100	C. CE. CHP	0.1uF 16V			チップセラコン	01
C811	US064100	C. CE. CHP	0.01uF 50V B			チップセラコン	01
C812	UR218470	C. EL	470uF 6.3V			ケミコン	
C813	US062120	C. CE. CHP	120pF 50V B			チップセラコン	01
C814	US062220	C. CE. CHP	220pF 50V B			チップセラコン	01
C815	UR237100	C. EL	10uF 16V			ケミコン	
C816	UR237470	C. EL	47uF 16V			ケミコン	
C821-822	US135100	C. CE. CHP	0.1uF 16V			チップセラコン	01
C824	US062220	C. CE. CHP	220pF 50V B			チップセラコン	01
C826	US062220	C. CE. CHP	220pF 50V B			チップセラコン	01

* New Parts * 新規部品

P.C.B. A-VIDEO

Ref No.	Part No.	Description	Remarks	Markets	部 品 名	Rank
D601-609	VU992500	DIODE. ZENR	MA8051-L 5.0V		J ツェナーダイオード	01
D611-612	VT332900	DIODE	1SS355		J ダイオード	01
D701-706	VT332900	DIODE	1SS355		J ダイオード	01
D771-774	VT332900	DIODE	1SS355		J ダイオード	01
D811-812	VT332900	DIODE	1SS355		J ダイオード	01
* IC601	X6757A00	IC	NJW1321FP1		J IC	
IC602	X2904A00	IC	NJM2581M VIDEO AMP		J アンプ IC SOP	06
* IC603-604	XY876A00	IC	MM74HC4052SJX_NL M		J ロジック IC SOP	
IC605	X2484A00	IC	TA1318AF		J IC	07
* IC606	X6758A00	IC	LA73054-TLM-E		J アンプ IC SOP	
IC607	XY877A00	IC	MM74HC4053SJX		J ロジック IC SOP	01
IC701	XY550A00	IC	MM74HC4051SJX		J ロジック IC SOP	01
IC703	XY550A00	IC	MM74HC4051SJX		J ロジック IC SOP	01
IC705	X4321A00	IC	CD4051BNSR		J ロジック IC	01
IC708	XY877A00	IC	MM74HC4053SJX		J ロジック IC SOP	01
* IC709	X6742A00	IC	LA73050-TLM-E		J アンプ IC SOP	
IC710	XZ177A00	IC	LA7104M VIDEO AMP		J アンプ IC SOP	04
IC712	XW939A00	IC	TK15420M VIDEO AMP		J アンプ IC SOP	03
IC713	XD598A00	IC	TC74HCU04AFEL INV		J ロジック IC	01
* IC714	X6849A00	IC	BD7851FP-E2		J ロジック IC	
IC715	X5597A00	IC	LC74781JM-9798		J IC アナログ	07
IC716	XY877A00	IC	MM74HC4053SJX		J ロジック IC SOP	01
J701-705		R. CHP	0Ω 1/16W J		RKTABGL チップ抵抗	
* JK701-702	WD396300	JACK. PIN	LAP5100-1601FC		J ピンジャック + S	
* JK703	WD396100	JACK. PIN	LAP5100-1801FC		J ピンジャック + S	
* PJ601-602	WD442700	JACK. PIN	LPR6520-M610FC		J ピンジャック 6 P	
PJ611-614	WD398400	CN. DIN	14P YKF45-3011		J DINコネクタ	05
PN701-702	V9637500	PIN	L=70 #18		J スタイルピン	
* Q601-602	WG261200	FET	2SK2158-T2B-A		J FET	
Q701	VW556400	TR	2SC2412K Q,R,S		J トランジスタ	01
* Q702	WF550000	TR	2SC3837K T146 N,P		J トランジスタ	
Q703	VW556500	TR	2SA1037K Q,R,S		J トランジスタ	01
* Q704	WF549900	TR	2SC3906K T146 R,S		J トランジスタ	
Q705	VZ725900	TR	2SD1938F S,T		J トランジスタ	
Q706	VW556400	TR	2SC2412K Q,R,S		J トランジスタ	01
* Q711-713	WG261200	FET	2SK2158-T2B-A		J FET	
Q717	VW556400	TR	2SC2412K Q,R,S		J トランジスタ	01
R621-629		R. CHP	100Ω 1/16W J		J チップ抵抗	
R630-632		R. CHP	10KΩ 1/16W J		J チップ抵抗	
R633-635		R. CHP	75Ω 1/16W J		J チップ抵抗	
R662	HV753100	R. CAR. FP	1Ω 1/4W		J 不燃化カーボン抵抗	01
R665	HV753100	R. CAR. FP	1Ω 1/4W		J 不燃化カーボン抵抗	01
R667	HV753100	R. CAR. FP	1Ω 1/4W		J 不燃化カーボン抵抗	01
R676-677	HV753100	R. CAR. FP	1Ω 1/4W		J 不燃化カーボン抵抗	01
R680	HV753100	R. CAR. FP	1Ω 1/4W		J 不燃化カーボン抵抗	01
R688-690	HV753100	R. CAR. FP	1Ω 1/4W		J 不燃化カーボン抵抗	01
R738-739	HV753100	R. CAR. FP	1Ω 1/4W		J 不燃化カーボン抵抗	01
R760-763	HV753100	R. CAR. FP	1Ω 1/4W		J 不燃化カーボン抵抗	01
R780	HV755470	R. CAR. FP	470Ω 1/4W		J 不燃化カーボン抵抗	01
R783	HV753220	R. CAR. FP	2.2Ω 1/4W		J 不燃化カーボン抵抗	01
R787	HV755470	R. CAR. FP	470Ω 1/4W		J 不燃化カーボン抵抗	01
R790-791	HV755470	R. CAR. FP	470Ω 1/4W		J 不燃化カーボン抵抗	01
R794-795	HV753100	R. CAR. FP	1Ω 1/4W		J 不燃化カーボン抵抗	01
R800	HV755470	R. CAR. FP	470Ω 1/4W		J 不燃化カーボン抵抗	01

* New Parts * 新規部品

P.C.B. A-VIDEO & P.C.B. D-VIDEO

Ref No.	Part No.	Description	Remarks	Markets	部 品 名	Rank
R812	HV753220	R. CAR. FP	2.2Ω 1/4W		不燃化カーボン抵抗	01
R821	HV753100	R. CAR. FP	1Ω 1/4W		不燃化カーボン抵抗	01
XL601	V5345200	RSNR. CE	CSBLA503KECZF30-B0		セラミック振動子	01
XL715	WC061400	RSNR. CRY	14.31818MHz SMD-49	JUCRK	水晶振動子	
XL715	V6074900	RSNR. CRY	17.734475MHz	TABGL	水晶振動子	03
*	WG081900	P. C. B.	D-VIDEO		P C B D-V I D E O	
CB302	V9356900	CN	JE 19P SE		J E コネクタプラグ	
CB501	V7828700	SOCKET	20P SE TUC SERIES		コネクタソケット	01
CB502	V8875300	CN	JE 13P SE		J E コネクタプラグ	01
CB504	V0044400	CN. BS. PIN	9P		F F C コネクタ	01
CB506	LB919020	CN. BS. PIN	2P		ベース付ポスト	01
CB507	V6509500	SOCKET	9P SE 3170		コネクタソケット	04
CB508	LB919040	CN. BS. PIN	4P		ベース付ポスト	01
CB510	V9356900	CN	JE 19P SE		J E コネクタプラグ	
* CN301-303	WC688700	CN	19P HDMI		コネクタ	
C301-302	US135100	C. CE. CHP	0.1uF 16V		チップセラコン	01
C303	V5333500	C. CE. CHP	10uF 6.3V		チップセラコン	01
C304-305	US063100	C. CE. CHP	1000pF 50V B		チップセラコン	01
C306-309	US135100	C. CE. CHP	0.1uF 16V		チップセラコン	01
C310-311	US063100	C. CE. CHP	1000pF 50V B		チップセラコン	01
C312	US135100	C. CE. CHP	0.1uF 16V		チップセラコン	01
C313	US063100	C. CE. CHP	1000pF 50V B		チップセラコン	01
C314-316	US135100	C. CE. CHP	0.1uF 16V		チップセラコン	01
C317	US063100	C. CE. CHP	1000pF 50V B		チップセラコン	01
C318-319	US135100	C. CE. CHP	0.1uF 16V		チップセラコン	01
C320	US063100	C. CE. CHP	1000pF 50V B		チップセラコン	01
C321-322	US064100	C. CE. CHP	0.01uF 50V B		チップセラコン	01
C323-325	V5333500	C. CE. CHP	10uF 6.3V		チップセラコン	01
C326	US135100	C. CE. CHP	0.1uF 16V		チップセラコン	01
C327-329	V5333500	C. CE. CHP	10uF 6.3V		チップセラコン	01
C330-344	US135100	C. CE. CHP	0.1uF 16V		チップセラコン	01
C345	US061150	C. CE. CHP	15pF 50V B		チップセラコン	01
C346	US064100	C. CE. CHP	0.01uF 50V B		チップセラコン	01
C350	US135100	C. CE. CHP	0.1uF 16V		チップセラコン	01
C351	US064100	C. CE. CHP	0.01uF 50V B		チップセラコン	01
C352	US061150	C. CE. CHP	15pF 50V B		チップセラコン	01
C353-363	US135100	C. CE. CHP	0.1uF 16V		チップセラコン	01
C364	UF018100	C. EL. CHP	100uF 6.3V		チップケミコン	01
C365-366	US135100	C. CE. CHP	0.1uF 16V		チップセラコン	01
C367	UF018100	C. EL. CHP	100uF 6.3V		チップケミコン	01
C368	US135100	C. CE. CHP	0.1uF 16V		チップセラコン	01
C381-383	US135100	C. CE. CHP	0.1uF 16V		チップセラコン	01
C384-387	US063100	C. CE. CHP	1000pF 50V B		チップセラコン	01
C388-389	US135100	C. CE. CHP	0.1uF 16V		チップセラコン	01
C390-392	US063100	C. CE. CHP	1000pF 50V B		チップセラコン	01
C509	US135100	C. CE. CHP	0.1uF 16V		チップセラコン	01
C510	US064100	C. CE. CHP	0.01uF 50V B		チップセラコン	01
C511	UF037100	C. EL. CHP	10uF 16V		チップケミコン	01
C512-513	US135100	C. CE. CHP	0.1uF 16V		チップセラコン	01
C514-515	UF037100	C. EL. CHP	10uF 16V		チップケミコン	01
C517-520	US135100	C. CE. CHP	0.1uF 16V		チップセラコン	01

* New Parts * 新規部品

P.C.B. D-VIDEO

Ref No.	Part No.	Description	Remarks	Markets	部 品 名	Rank	
C521-522	US064100	C. CE. CHP	0.01uF	50V B		チップセラコン	01
C524	UF037100	C. EL. CHP	10uF	16V		チップケミコン	01
C525-531	US135100	C. CE. CHP	0.1uF	16V		チップセラコン	01
C532	US064100	C. CE. CHP	0.01uF	50V B		チップセラコン	01
C533	US063100	C. CE. CHP	1000pF	50V B		チップセラコン	01
C534	US064100	C. CE. CHP	0.01uF	50V B		チップセラコン	01
* C536	US034820	C. CE. CHP	0.082uF	16V K		チップセラコン	01
C538	US064100	C. CE. CHP	0.01uF	50V B		チップセラコン	01
C539	US135100	C. CE. CHP	0.1uF	16V		チップセラコン	01
C540	US060700	C. CE. CHP	7pF	50V B		チップセラコン	01
C541	US064100	C. CE. CHP	0.01uF	50V B		チップセラコン	01
C542-543	US135100	C. CE. CHP	0.1uF	16V		チップセラコン	01
C544	US060700	C. CE. CHP	7pF	50V B		チップセラコン	01
C545	UF018100	C. EL. CHP	100uF	6.3V		チップケミコン	01
C546	US135100	C. CE. CHP	0.1uF	16V		チップセラコン	01
C548	US135100	C. CE. CHP	0.1uF	16V		チップセラコン	01
C549-555	UF018100	C. EL. CHP	100uF	6.3V		チップケミコン	01
C558	US064100	C. CE. CHP	0.01uF	50V B		チップセラコン	01
C559	US135100	C. CE. CHP	0.1uF	16V		チップセラコン	01
C560-561	US064100	C. CE. CHP	0.01uF	50V B		チップセラコン	01
C562-563	US135100	C. CE. CHP	0.1uF	16V		チップセラコン	01
C564	UF037470	C. EL. CHP	47uF	16V		チップケミコン	01
C567	US062820	C. CE. CHP	820pF	50V B		チップセラコン	01
C568-569	US135100	C. CE. CHP	0.1uF	16V		チップセラコン	01
C570	US063390	C. CE. CHP	3900pF	50V B		チップセラコン	01
C571-572	US135100	C. CE. CHP	0.1uF	16V		チップセラコン	01
C583-584	UF037100	C. EL. CHP	10uF	16V		チップケミコン	01
C587	US135100	C. CE. CHP	0.1uF	16V		チップセラコン	01
C598	UF037100	C. EL. CHP	10uF	16V		チップケミコン	01
C600	UF037100	C. EL. CHP	10uF	16V		チップケミコン	01
C601-602	US135100	C. CE. CHP	0.1uF	16V		チップセラコン	01
C603	UF037470	C. EL. CHP	47uF	16V		チップケミコン	01
C609	UF037470	C. EL. CHP	47uF	16V		チップケミコン	01
C610	US135100	C. CE. CHP	0.1uF	16V		チップセラコン	01
C612-620	US135100	C. CE. CHP	0.1uF	16V		チップセラコン	01
C621	UF037470	C. EL. CHP	47uF	16V		チップケミコン	01
C622-629	US135100	C. CE. CHP	0.1uF	16V		チップセラコン	01
C630	UF037470	C. EL. CHP	47uF	16V		チップケミコン	01
C631	US135100	C. CE. CHP	0.1uF	16V		チップセラコン	01
C633-636	US135100	C. CE. CHP	0.1uF	16V		チップセラコン	01
C638-639	US135100	C. CE. CHP	0.1uF	16V		チップセラコン	01
C640	UF037470	C. EL. CHP	47uF	16V		チップケミコン	01
C641-643	US135100	C. CE. CHP	0.1uF	16V		チップセラコン	01
C644	US063100	C. CE. CHP	1000pF	50V B		チップセラコン	01
C645	US135100	C. CE. CHP	0.1uF	16V		チップセラコン	01
C647	US135100	C. CE. CHP	0.1uF	16V		チップセラコン	01
C651-652	UR238470	C. EL	470uF	16V		ケミコン	
C654-657	US135100	C. CE. CHP	0.1uF	16V		チップセラコン	01
C660	UF018100	C. EL. CHP	100uF	6.3V		チップケミコン	01
C663-664	US135100	C. CE. CHP	0.1uF	16V		チップセラコン	01
C666-667	UR237470	C. EL	47uF	16V		ケミコン	
C669-670	UR238470	C. EL	470uF	16V		ケミコン	
C673	US135100	C. CE. CHP	0.1uF	16V		チップセラコン	01
C675-676	US135100	C. CE. CHP	0.1uF	16V		チップセラコン	01

* New Parts * 新規部品

P.C.B. D-VIDEO

Ref No.	Part No.	Description	Remarks	Markets	部 品 名	Rank
C679-680	US135100	C. CE. CHP	0.1uF 16V		チップセラコン	01
C684	UF037470	C. EL. CHP	47uF 16V		チップケミコン	01
C685-686	UR237470	C. EL	47uF 16V		ケミコン	
C689	US064100	C. CE. CHP	0.01uF 50V B		チップセラコン	01
C690	UF037470	C. EL. CHP	47uF 16V		チップケミコン	01
C691-693	US135100	C. CE. CHP	0.1uF 16V		チップセラコン	01
C697-699	US135100	C. CE. CHP	0.1uF 16V		チップセラコン	01
C700-701	US135100	C. CE. CHP	0.1uF 16V		チップセラコン	01
C704-705	US135100	C. CE. CHP	0.1uF 16V		チップセラコン	01
C706-708	US064100	C. CE. CHP	0.01uF 50V B		チップセラコン	01
C710	US064100	C. CE. CHP	0.01uF 50V B		チップセラコン	01
C714	US135100	C. CE. CHP	0.1uF 16V		チップセラコン	01
C726	US135100	C. CE. CHP	0.1uF 16V		チップセラコン	01
C740	US135100	C. CE. CHP	0.1uF 16V		チップセラコン	01
C741	US063100	C. CE. CHP	1000pF 50V B		チップセラコン	01
C742	US135100	C. CE. CHP	0.1uF 16V		チップセラコン	01
C743	US063100	C. CE. CHP	1000pF 50V B		チップセラコン	01
C744	US135100	C. CE. CHP	0.1uF 16V		チップセラコン	01
C745	US063100	C. CE. CHP	1000pF 50V B		チップセラコン	01
C746	US135100	C. CE. CHP	0.1uF 16V		チップセラコン	01
C747	US063100	C. CE. CHP	1000pF 50V B		チップセラコン	01
C748-749	US135100	C. CE. CHP	0.1uF 16V		チップセラコン	01
C750	US063100	C. CE. CHP	1000pF 50V B		チップセラコン	01
C751-752	US135100	C. CE. CHP	0.1uF 16V		チップセラコン	01
C753	US063100	C. CE. CHP	1000pF 50V B		チップセラコン	01
C754	US135100	C. CE. CHP	0.1uF 16V		チップセラコン	01
C755	US063100	C. CE. CHP	1000pF 50V B		チップセラコン	01
C756-757	US135100	C. CE. CHP	0.1uF 16V		チップセラコン	01
C758	US063100	C. CE. CHP	1000pF 50V B		チップセラコン	01
C759-762	US135100	C. CE. CHP	0.1uF 16V		チップセラコン	01
C763	US063100	C. CE. CHP	1000pF 50V B		チップセラコン	01
C764-767	US135100	C. CE. CHP	0.1uF 16V		チップセラコン	01
C771	US063100	C. CE. CHP	1000pF 50V B		チップセラコン	01
C772	US126100	C. CE. CHP	1uF 10V		チップセラコン	01
C773	US063100	C. CE. CHP	1000pF 50V B		チップセラコン	01
C774	US126100	C. CE. CHP	1uF 10V		チップセラコン	01
C775-780	US063100	C. CE. CHP	1000pF 50V B		チップセラコン	01
C781	US126100	C. CE. CHP	1uF 10V		チップセラコン	01
C782	US063100	C. CE. CHP	1000pF 50V B		チップセラコン	01
C783	US126100	C. CE. CHP	1uF 10V		チップセラコン	01
C784-786	US064100	C. CE. CHP	0.01uF 50V B		チップセラコン	01
C787	US135100	C. CE. CHP	0.1uF 16V		チップセラコン	01
C789	US135100	C. CE. CHP	0.1uF 16V		チップセラコン	01
D312	VT332900	DIODE	1SS355		ダイオード	01
D315	VT332900	DIODE	1SS355		ダイオード	01
D318	VT332900	DIODE	1SS355		ダイオード	01
D321-325	VT332900	DIODE	1SS355		ダイオード	01
D601-603	VT332900	DIODE	1SS355		ダイオード	01
D605-608	VT332900	DIODE	1SS355		ダイオード	01
D610-617	VT332900	DIODE	1SS355		ダイオード	01
IC301-302	X4503A00	IC	SN74CBT3306PWR		ロジックIC	03
IC303-304	X3530A00	IC	24LC04BT-1/SN		メモリIC SOIC	03
IC305	X4061A00	IC	SN74AHC2GU04HDCTR		ロジックIC	01
IC306	X5817A00	IC	LE50ABD 5.0V 0.1A		電源IC	05

* New Parts * 新規部品

P.C.B. D-VIDEO

Ref No.	Part No.	Description	Remarks	Markets	部 品 名	Rank
IC307	X3801A00	IC			ロジックIC	11
IC308	X5816A00	IC, CPU	SN74LV01G125DCKR		CPU/周辺IC	16
IC309	X5815A00	IC, CPU	SI19031CTU HDMI TX		CPU/周辺IC	04
IC310	X5818A00	IC, CPU	PC9540BDP 12C MIX		CPU/周辺IC	02
IC311	XZ287A00	IC	SN74V0245APMR		電源IC	05
IC312	X5827A00	IC	UPC37M31TJ-E1-AZ		ロジックIC	01
IC314	X4465A00	IC	SN74AHCT1G125DCKR		CPU/周辺IC	09
IC501	XZ965A00	IC, CPU	M3080SS3P		ビデオエンコーダ	
IC503	X6802A00	IC	ADV7401BSTZ-80		IC 1Pコンバータ	
IC504	X6801A00	IC	ADV7322KSTZ		IC 1Pコンバータ	
IC505	X6853A00	IC	MAT1SE 1A G		IC 1Pコンバータ	
IC507	X7220A00	IC	S29L032H70TF1020		メモリアIC	
IC509	XZ590B00	IC	W981666CH-7 SDRAM		メモリアIC 16M	06
IC510-512	X5741A00	IC	SN74LV0541APMR		ロジックIC	02
IC520	XZ709A00	IC	SN74AHCT1G125DCKR		ロジックIC	02
IC521	X4463A00	IC	SN74LV08APMR		ロジックIC	01
IC522	X3824A00	IC	SN74AHCT08PMR		ロジックIC	
IC524	X6848A00	IC	LA73053-TLM-E		ソケットIC	
IC525	X7171A00	IC	SN74LV02G125DQIR		ロジックIC	01
IC526	X4465A00	IC	SN74AHCT1G125DCKR		ロジックIC	01
IC527	XZ000A00	IC	PS19242NR		ロジックIC	01
IC528	X4454A00	IC	SN74LV02G17DCKR		IC	
IC529	X6876A00	IC	ADM222ARZ		電源IC	03
IC601	X5826A00	IC	UPC2905AT-E1-AZ		電源IC	
IC602	X6869A00	IC	NJM2885DL1-33		電源IC	
IC603	X6870A00	IC	NJM2845DL1-33		電源IC	
IC605	X6867A00	IC	NJM2391DL1-25		電源IC	
IC606	X6868A00	IC	NJM2885DL1-18		電源IC	
IC607-609	X5741A00	IC	SN74LV0541APMR		ロジックIC	02
PS301	VZ997600	IC	SMD0050-02		ボリアイッチ	01
0301-302	V0986700	TR	ZSC4081 T106		トランジスタ	01
0309	WE834500	FET	UPA672T-T1-A		FET	01
0310-311	WD760200	FET	2N7002-NL TP		FET	01
0501-504	V0986700	TR	ZSC4081 T106		トランジスタ	01
0505-508	WG261200	FET	2SK2158-T2B-A		FET	01
R630-632	VP939700	R, MTL, FLM	4.7Ω 1W		金属被膜抵抗	01
R637	VP939700	R, MTL, FLM	4.7Ω 1W		金属被膜抵抗	01
R642	VP939600	R, MTL, FLM	2.2Ω 1W		金属被膜抵抗	01
R643	WB784100	R, MTL, FLM	1.2Ω 1W		金属被膜抵抗	01
RV309-332	WE674800	DIODE	AVR161A1RINTB		チップバリスタ	01
ST301	V4040500	SCR, TERM	M3		スクリュー/ターミナル	01
XL301	VZ268400	FSNR, CRYS	27MHz SMD-49		水晶振動子	05
XL501	V9864200	FSNR, CE	10.0MHz		セラミック発振子	01
XL502	VZ772700	FSNR, CRYS	28.63636MHz		水晶振動子	03

* New Parts * 新規部品

Chip Resistors

● The chip resistor is not supplied as a replacement part.
 * When a chip resistor is necessary, use the following part.
 AAX60720: CHIP RESISTOR SAMPLE BOOK

● チップ抵抗はサービスタ部品として供給しません。
 * チップ抵抗が必要な場合は、下記の部品をご利用ください。
 AAX60720: CHIP RESISTOR SAMPLE BOOK

Ref No.	Part No.	Description	Remarks	Markets	部 品 名	Rank
	R, GHP	3KΩ	1/16W J		チップ抵抗	
	R, GHP	0Ω	1/16W J		チップ抵抗	
	R, GHP	10Ω	1/16W J		チップ抵抗	
	R, GHP	22Ω	1/16W J		チップ抵抗	
	R, GHP	47Ω	1/16W J		チップ抵抗	
	R, GHP	56Ω	1/16W J		チップ抵抗	
	R, GHP	75Ω	1/16W J		チップ抵抗	
	R, GHP	100Ω	1/16W J		チップ抵抗	
	R, GHP	120Ω	1/16W J		チップ抵抗	
	R, GHP	470Ω	1/16W J		チップ抵抗	
	R, GHP	1KΩ	1/16W J		チップ抵抗	
	R, GHP	1.2KΩ	1/16W J		チップ抵抗	
	R, GHP	1.5KΩ	1/16W J		チップ抵抗	
	R, GHP	1.8KΩ	1/16W J		チップ抵抗	
	R, GHP	2.2KΩ	1/16W J		チップ抵抗	
	R, GHP	4.7KΩ	1/16W J		チップ抵抗	
	R, GHP	6.8KΩ	1/16W J		チップ抵抗	
	R, GHP	10KΩ	1/16W J		チップ抵抗	
	R, GHP	15KΩ	1/16W J		チップ抵抗	
	R, GHP	22KΩ	1/16W J		チップ抵抗	
	R, GHP	33KΩ	1/16W J		チップ抵抗	
	R, GHP	47KΩ	1/16W J		チップ抵抗	
	R, GHP	100KΩ	1/16W J		チップ抵抗	
	R, GHP	470KΩ	1/16W J		チップ抵抗	
	R, GHP	1MΩ	1/16W J		チップ抵抗	
	R, MTL, GHP	2.2KΩ	1/16W D		チップ金属被膜抵抗	
	R, MTL, GHP	3.3KΩ	1/16W D		チップ金属被膜抵抗	

* New Parts * 新規部品

EXPLODED VIEW

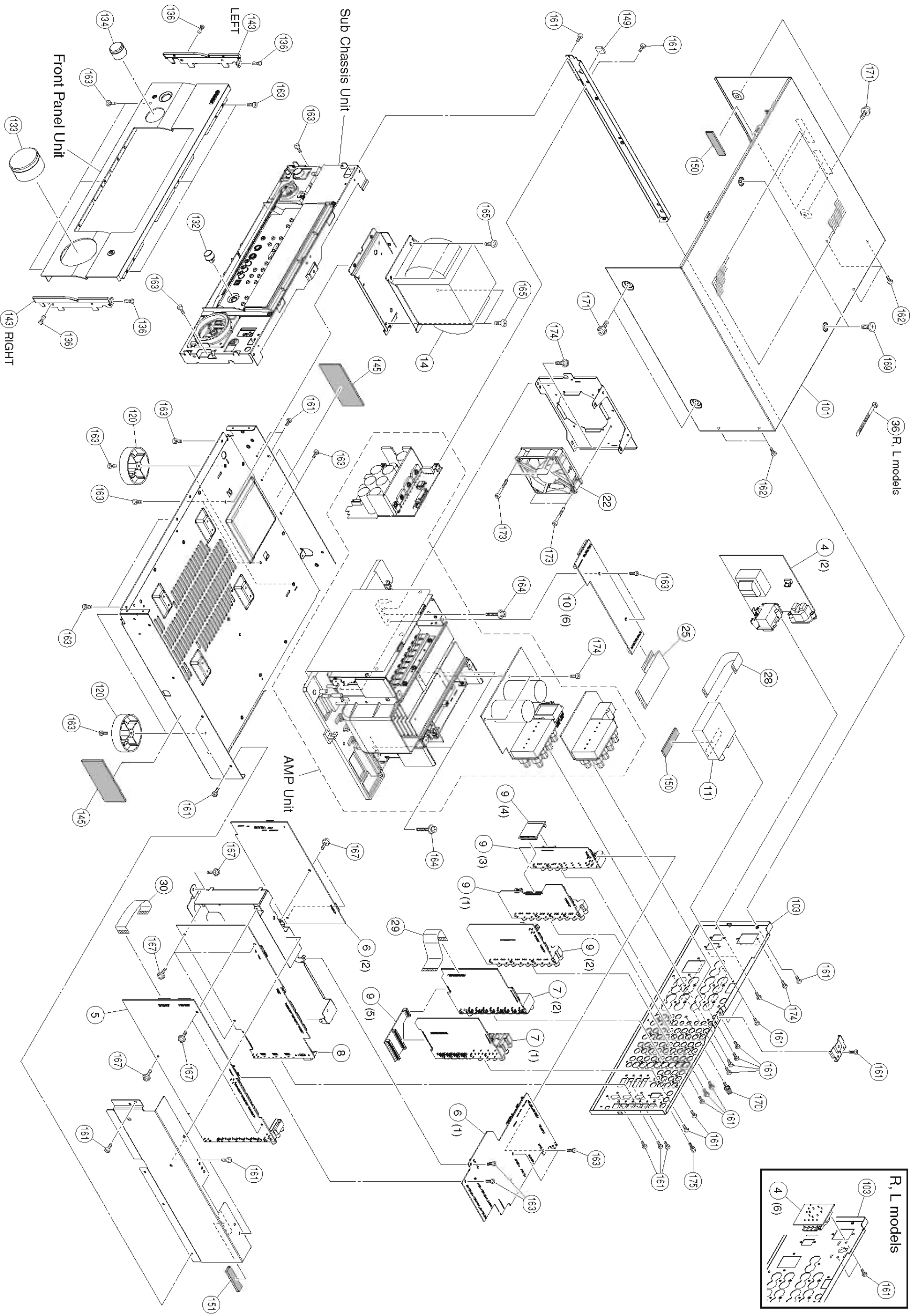

MECHANICAL PARTS

RefNo.	Part No.	Description	Remarks	Markets	部 品 名	Rank
*	4	WG076300 P.C.B. ASS'Y	POWER	J UC	P C B	パワ-
*	4	WG076400 P.C.B. ASS'Y	POWER	UC	P C B	パワ-
*	4	WG076500 P.C.B. ASS'Y	POWER	R	P C B	パワ-
*	4	WG076600 P.C.B. ASS'Y	POWER	T	P C B	パワ-
*	4	WG076700 P.C.B. ASS'Y	POWER	K	P C B	パワ-
*	4	WG076800 P.C.B. ASS'Y	POWER	A	P C B	パワ-
*	4	WG076900 P.C.B. ASS'Y	POWER	B	P C B	パワ-
*	4	WG077000 P.C.B. ASS'Y	POWER	G	P C B	パワ-
*	4	WG077100 P.C.B. ASS'Y	POWER	L	P C B	パワ-
*	5	WG078300 P.C.B. ASS'Y	DSP	JRTKABGL	P C B	D S P
*	5	WG078400 P.C.B. ASS'Y	DSP	UC	P C B	D S P
*	6	WG079100 P.C.B. ASS'Y	FUNCTION	J	P C B	フ-クシヨ
*	6	WG079200 P.C.B. ASS'Y	FUNCTION	UC	P C B	フ-クシヨ
*	6	WG079300 P.C.B. ASS'Y	FUNCTION	R	P C B	フ-クシヨ
*	6	WG079400 P.C.B. ASS'Y	FUNCTION	T	P C B	フ-クシヨ
*	6	WG079500 P.C.B. ASS'Y	FUNCTION	K	P C B	フ-クシヨ
*	6	WG079600 P.C.B. ASS'Y	FUNCTION	T	P C B	フ-クシヨ
*	6	WG079700 P.C.B. ASS'Y	FUNCTION	A	P C B	フ-クシヨ
*	6	WG079800 P.C.B. ASS'Y	FUNCTION	BG	P C B	フ-クシヨ
*	6	WG079900 P.C.B. ASS'Y	FUNCTION	L	P C B	フ-クシヨ
*	7	WG080900 P.C.B. ASS'Y	A-VIDEO	J	P C B	フ-クシヨ
*	7	WG081000 P.C.B. ASS'Y	A-VIDEO	UC	P C B	フ-クシヨ
*	7	WG081100 P.C.B. ASS'Y	A-VIDEO	RK	P C B	フ-クシヨ
*	7	WG081200 P.C.B. ASS'Y	A-VIDEO	TABGL	P C B	フ-クシヨ
*	8	WG081900 P.C.B. ASS'Y	D-VIDEO	JRTKABGL	P C B	フ-クシヨ
*	9	WG082300 P.C.B. ASS'Y	INPUT	UC	P C B	フ-クシヨ
*	9	WG083000 P.C.B. ASS'Y	INPUT	JUC	P C B	フ-クシヨ
*	10	WG083100 P.C.B. ASS'Y	OPERATION	RTKABGL	P C B	フ-クシヨ
*	11	WD048200 AM/FM TUNER	OPERATION	J	AM/FM	チューナ-
*	11	WD048300 AM/FM TUNER	FACE385-401F	UCRTL	AM/FM	チューナ-
*	11	WD048400 AM/FM TUNER	FACE385-401F	KABG	AM/FM	チューナ-
*	14	X7036A00 POWER TRANSFORMER	POWER TRANSFORMER	J UC	電源トランス	
*	14	X7037A00 POWER TRANSFORMER	POWER TRANSFORMER	UC	電源トランス	
*	14	X7038A00 POWER TRANSFORMER	POWER TRANSFORMER	RL	電源トランス	
*	14	X7039A00 POWER TRANSFORMER	POWER TRANSFORMER	TK	電源トランス	
*	14	X7040A00 POWER TRANSFORMER	POWER TRANSFORMER	A	電源トランス	
*	14	X7041A00 POWER TRANSFORMER	POWER TRANSFORMER	BG	電源トランス	
*	22	V8466600 DC FAN MOTOR 24V	DC D08A-24TG		DCファンモ-タ	2 4
*	25	ME131120 FLEXIBLE FLAT CABLE	31P 120mm P=1.25		カード電線 C&C	
*	28	ME115140 FLEXIBLE FLAT CABLE	15P 140mm P=1.25		カード電線 C&C	
*	29	ME127100 FLEXIBLE FLAT CABLE	27P 100mm P=1.25		カード電線 C&C	
*	30	ME119070 FLEXIBLE FLAT CABLE	19P 70mm P=1.25		カード電線 C&C	
*	36	VZ825600 BINDING TIE	SEI40 L=140	RL	ケーブルタイ	
*	101	WE753800 TOP COVER	TOP COVER	GD	トップカバー	
*	101	WE753700 TOP COVER	TOP COVER	BL	トップカバー	
*	101	WE753900 TOP COVER	TOP COVER	TI	トップカバー	
*	103	WF553400 REAR PANEL	REAR PANEL	J UC	リアパネル	
*	103	WF552700 REAR PANEL	REAR PANEL	R	リアパネル	
*	103	WF552800 REAR PANEL	REAR PANEL	T	リアパネル	
*	103	WF552900 REAR PANEL	REAR PANEL	K	リアパネル	
*	103	WF553100 REAR PANEL	REAR PANEL	A	リアパネル	
*	103	WF553200 REAR PANEL	REAR PANEL	B	リアパネル	
*	103	WF553300 REAR PANEL	REAR PANEL	G	リアパネル	
*	103	WF553500 REAR PANEL	REAR PANEL	L	リアパネル	
*	120	V0042500 LEG	LEG	GD	レッグ	
*	120	V9025000 LEG	LEG	BL, TI	レッグ	
*	132	WF060100 KNOB D15	KNOB D15	GD	ノブ D 1 5	

* New Parts * 新規部品

RefNo.	Part No.	Description	Remarks	Markets	部 品 名	Rank
*	132	WF060000 KNOB D15	KNOB D15	BL	ノブ D 1 5	01
*	132	WF060200 KNOB D15	KNOB D15	TI	ノブ D 1 5	01
*	133	WD404500 KNOB D50	KNOB D50	GD	ノブD 5 0	08
*	133	WD404400 KNOB D50	KNOB D50	BL	ノブD 5 0	08
*	133	WD404600 KNOB D50	KNOB D50	TI	ノブD 5 0	08
*	134	WD405200 KNOB D23	KNOB D23	GD	ノブD 2 3	06
*	134	WD405100 KNOB D23	KNOB D23	BL	ノブD 2 3	06
*	134	WD405300 KNOB D23	KNOB D23	TI	ノブD 2 3	06
*	136	V0368600 PUSH RIVET	PUSH RIVET	TI	プッシュリベット	01
*	140	W6692000 BARRIER TRANS	BARRIER TRANS	GD	バリヤ/トランス	01
*	143	WD405500 PLATE SIDE	PLATE SIDE	BL	プレート/サイド	01
*	143	WD405400 PLATE SIDE	PLATE SIDE	TI	プレート/サイド	01
*	143	WD405600 PLATE SIDE	PLATE SIDE	TI	プレート/サイド	01
*	145	V3198100 DAMPER	DAMPER	GD	ダンパー	01
*	149	WF473000 DAMPER TRAY	DAMPER TRAY	GD	ダンパー/トレイ	01
*	150	VZ117100 DAMPER T2	DAMPER T2	TOP-F	ダンパー/T 2	01
*	151	V5658200 DAMPER TR	DAMPER TR	GD	ダンパー/TR	01
*	161	WE774100 BIND HEAD BONDING B-TL SCREW	BIND HEAD BONDING B-TL SCREW	3x8	ボンドネジBタイトネジ	01
*	162	WE774400 BIND HEAD B-TIGHT SCREW	BIND HEAD B-TIGHT SCREW	3x8	ボンドネジBタイトネジ	01
*	163	WE936300 BIND HEAD B-TIGHT SCREW	BIND HEAD B-TIGHT SCREW	3x6	ボンドネジBタイトネジ	01
*	164	WE774600 SCREW IC	SCREW IC	3x18	ボンドネジBタイトネジ	01
*	165	WE774700 BIND HEAD S-TIGHT SCREW	BIND HEAD S-TIGHT SCREW	4x10	ボンドネジSタイトネジ	01
*	167	VT669300 PW HEAD B-TIGHT SCREW	PW HEAD B-TIGHT SCREW	3x8-8	PWヘッドBタイトネジ	01
*	169	VZ893000 SPECIAL S-TIGHT SCREW	SPECIAL S-TIGHT SCREW	4x8-10	化粧ネジSタイト	01
*	169	VK522100 SPECIAL S-TIGHT SCREW	SPECIAL S-TIGHT SCREW	4x8-10	化粧ネジSタイト	01
*	170	AA627310 GROUND TERMINAL	GROUND TERMINAL	4x8-10	GNDターミナル	01
*	171	VD069600 PW HEAD S-TIGHT SCREW	PW HEAD S-TIGHT SCREW	4x8-10	PWヘッドSタイトネジ	01
*	171	VH313200 PW HEAD S-TIGHT SCREW	PW HEAD S-TIGHT SCREW	4x8-10	PWヘッドSタイトネジ	01
*	173	WE774500 BIND HEAD B-TIGHT SCREW	BIND HEAD B-TIGHT SCREW	3x30	ボンドネジBタイトネジ	01
*	174	WE774800 BIND HEAD P-TIGHT SCREW	BIND HEAD P-TIGHT SCREW	3x8	ボンドネジPタイトネジ	01
*	175	V6509600 JACK SCREW	JACK SCREW	SS6-447511848	ジャックネジスクリュー	01

* New Parts * 新規部品

ACCESSORIES

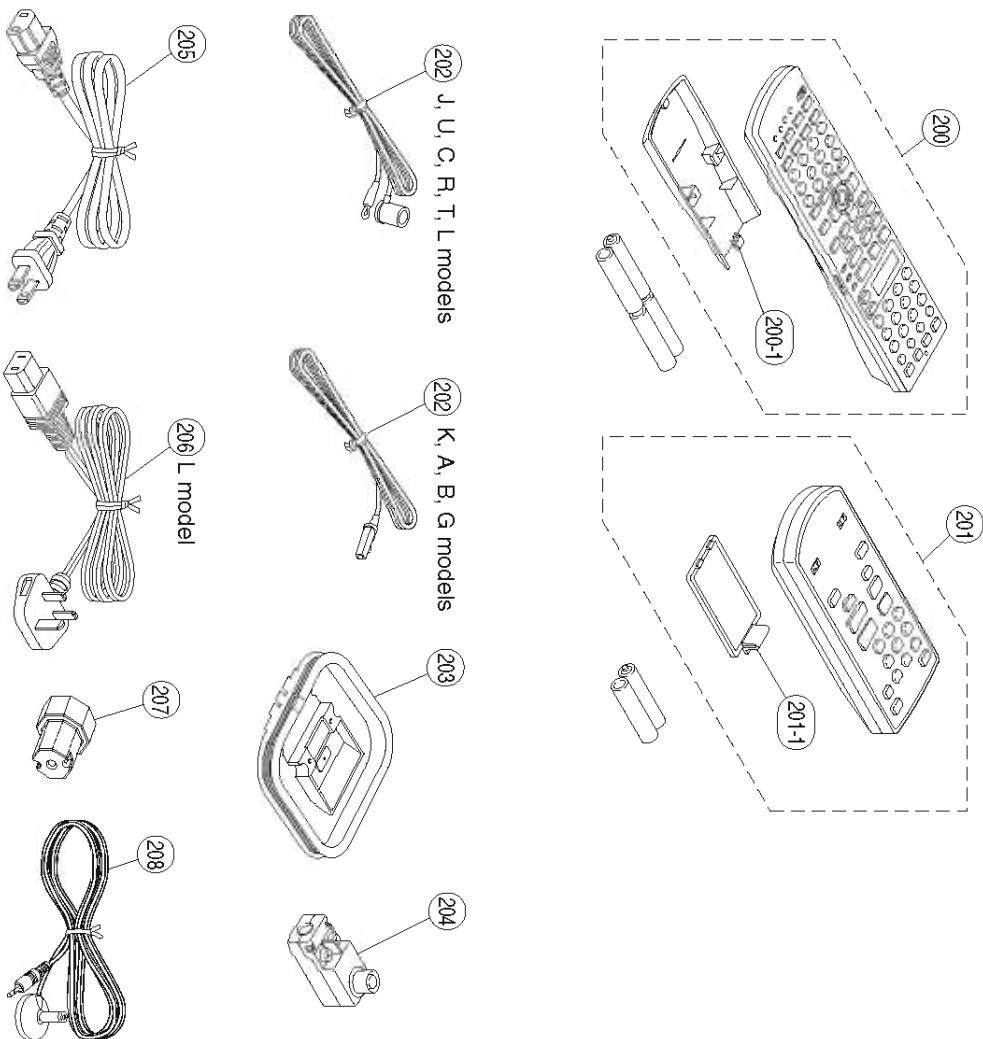

RefNo.	Part No.	Description	Remarks	Markets	部 品 名	Rank
		ACCESSORIES				
200	WF365500	REMOTE CONTROL	RC1596008/00	JRTKABGL	付属品 リモコン	
200	WF365400	REMOTE CONTROL	RC1596007/00	UC	リモコン	
200-1	AAXS9640	BATTERY COVER	3139 238 08051		電池蓋	02
201	WF121700	ZONE2/3 REMOTE CONTROL	YMA2J5N4504698-J	JRTKABGL	ゾーンリモコン	
201	WF121800	ZONE2/3 REMOTE CONTROL	YMA2J5N4505458-J	UC	ゾーンリモコン	
201-1	AAAX70730	BATTERY COVER	CG-8912		電池蓋	04
202	V6267000	INDOOR FM ANTENNA		JUCRTL	F M簡易アンテナ	03
202	VD147100	INDOOR FM ANTENNA		KABG	F M簡易アンテナ	02
203	VR248500	AM LOOP ANTENNA			電池蓋	03
204	VE364900	ANTENNA ADAPTER			AMルーフアンテナ	03
205	WA642300	POWER CABLE		B	整流器	07
205	V7704800	POWER CABLE		J	電源コード	05
205	WD107700	POWER CABLE		R	電源コード	05
205	V9358400	POWER CABLE		T	電源コード	05
205	V7704900	POWER CABLE		KGL	電源コード	06
205	WB750900	POWER CABLE		A	電源コード	07
205	WB751000	POWER CABLE		B	電源コード	08
206	WB751000	POWER CABLE		L	電源コード	08
207	WC080100	SPEAKER TERMINAL WRENCH	LTS00090-0002GM 1pc		S Pターミナルレンチ	01
208	WB929200	OPTIMIZER MICROPHONE BATTERY (MANGANESE DRY)	EMX-251 6m 1pc UM-4E 6pcs		マイク用電池 マンガン電池 6 p c s	08
		SERVICE TOOL				
	MF117350	FLEXIBLE FLAT CABLE			カービス部品	
	MF124500	FLEXIBLE FLAT CABLE			カード電線 C & C	02
	MF131500	FLEXIBLE FLAT CABLE			カード電線 C & C	10
	MF404250	CRIMPING ASS'Y B&C			圧接ASSY B & C	
	MF405400	CRIMPING ASS'Y B&C			圧接ASSY B & C	
	MF408250	CRIMPING ASS'Y B&C			圧接ASSY B & C	

* New Parts * 新規部品

AMP UNIT

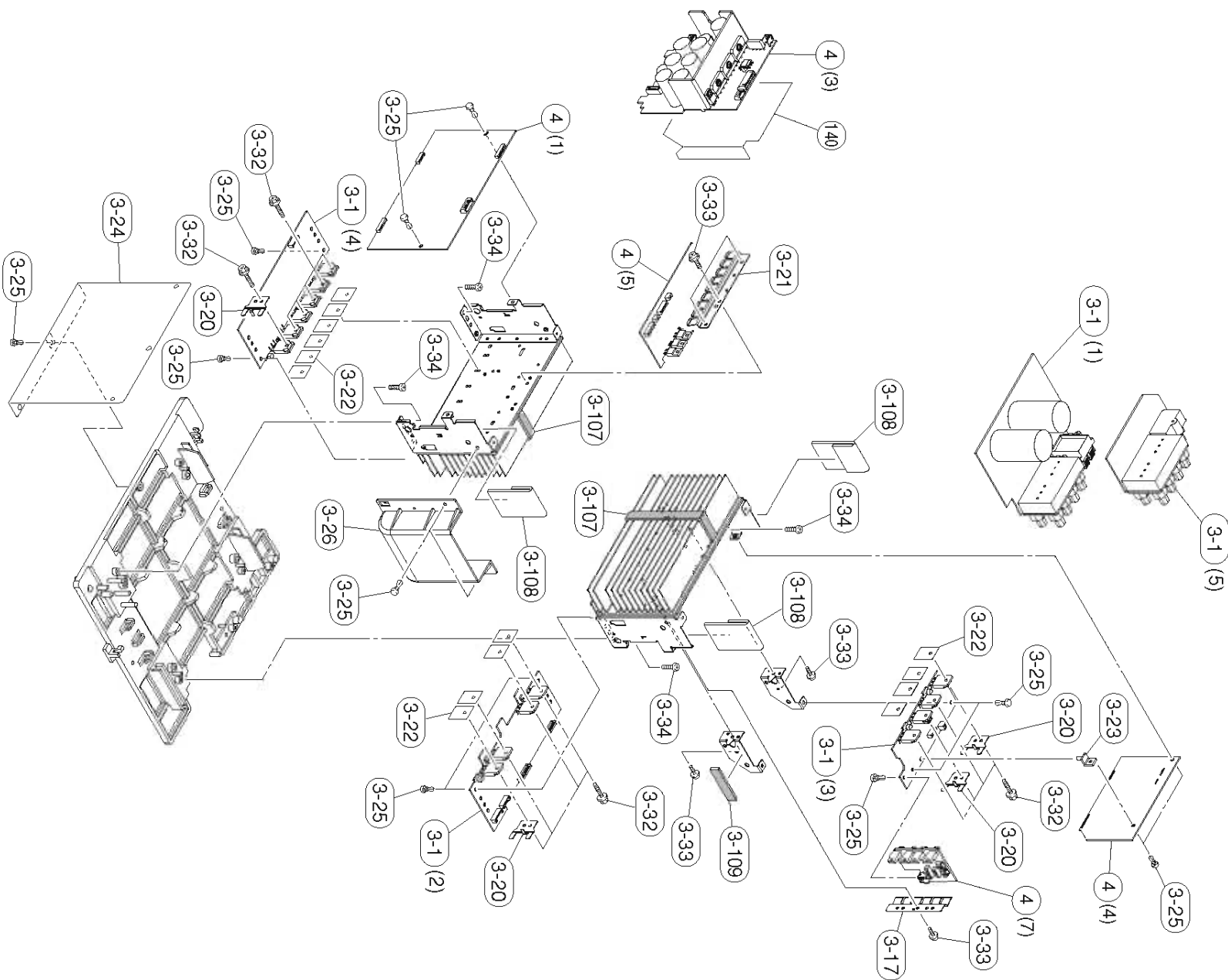

RefNo.	Part No.	Description	Remarks	Markets	部 品 名	Rank
3-1	WG075400	P.C.B. ASS'Y		J	P.C.B. ヌｲﾝ	
3-1	WG075500	P.C.B. ASS'Y		UC	P.C.B. ヌｲﾝ	
3-1	WG075600	P.C.B. ASS'Y		RTA	P.C.B. ヌｲﾝ	
3-1	WG075700	P.C.B. ASS'Y		KBGL	P.C.B. ヌｲﾝ	
3-17	WG32400	SUPPORT TR-6			サポ-ﾄ/TR-6	02
3-20	WB297600	SUPPORT TR			サポ-ﾄ/TR	
3-21	WD418800	SUPPORT TR-9			サポ-ﾄ/TR-9	03
3-22	VW849300	RADIATION SHEET	19x24		ｼｰﾄ/放射	01
3-23	CB091290	SUPPORT P.C.B.	No.1645		ｼｰﾄ/ｼｰﾙﾄﾞ	01
3-24	WA207000	SHEET SHIELD B			ｼｰﾄ/ｼｰﾙﾄﾞ	03
3-25	VO368600	PUSH RIVET	P3555-B		ﾀﾞｸﾄ	01
3-26	V9120600	DUCT			ﾀﾞｸﾄ	02
3-32	VK173200	SCREEN TRANSISTOR	3x15 SP		ｽｸﾘﾝ-TR	01
3-33	VT669300	PW HEAD B-TIGHT SCREW	3x8-8		P.W.ﾊｯﾄﾞBﾀｲﾄﾈｼ	01
3-34	WE774800	BLIND HEAD P-TIGHT SCREW	3x8		ﾊｲﾝﾄﾞPﾀｲﾄﾈｼ	01
3-107	VP922500	DAMPER	2x10x170		ﾀﾝﾊﾟ-	01
3-108	V3198100	DAMPER			ﾀﾝﾊﾟ-	01
3-109	VZ117100	DAMPER T2	GUARD		ﾀﾝﾊﾟ-/T2	01
4	WG076300	P.C.B. ASS'Y	TOP-F	J	P.C.B. ｲ7-	
4	WG076400	P.C.B. ASS'Y	POWER	UC	P.C.B. ｲ7-	
4	WG076500	P.C.B. ASS'Y	POWER	R	P.C.B. ｲ7-	
4	WG076600	P.C.B. ASS'Y	POWER	T	P.C.B. ｲ7-	
4	WG076700	P.C.B. ASS'Y	POWER	K	P.C.B. ｲ7-	
4	WG076800	P.C.B. ASS'Y	POWER	A	P.C.B. ｲ7-	
4	WG076900	P.C.B. ASS'Y	POWER	B	P.C.B. ｲ7-	
4	WG077000	P.C.B. ASS'Y	POWER	G	P.C.B. ｲ7-	
4	WG077100	P.C.B. ASS'Y	POWER	L	P.C.B. ｲ7-	
140	WS662000	BARRIER TRANS			ﾊﾞﾘｱ/ﾄﾗﾝｽ	

REMOTE CONTROL RAV 356, RAV357

SCHEMATIC DIAGRAM

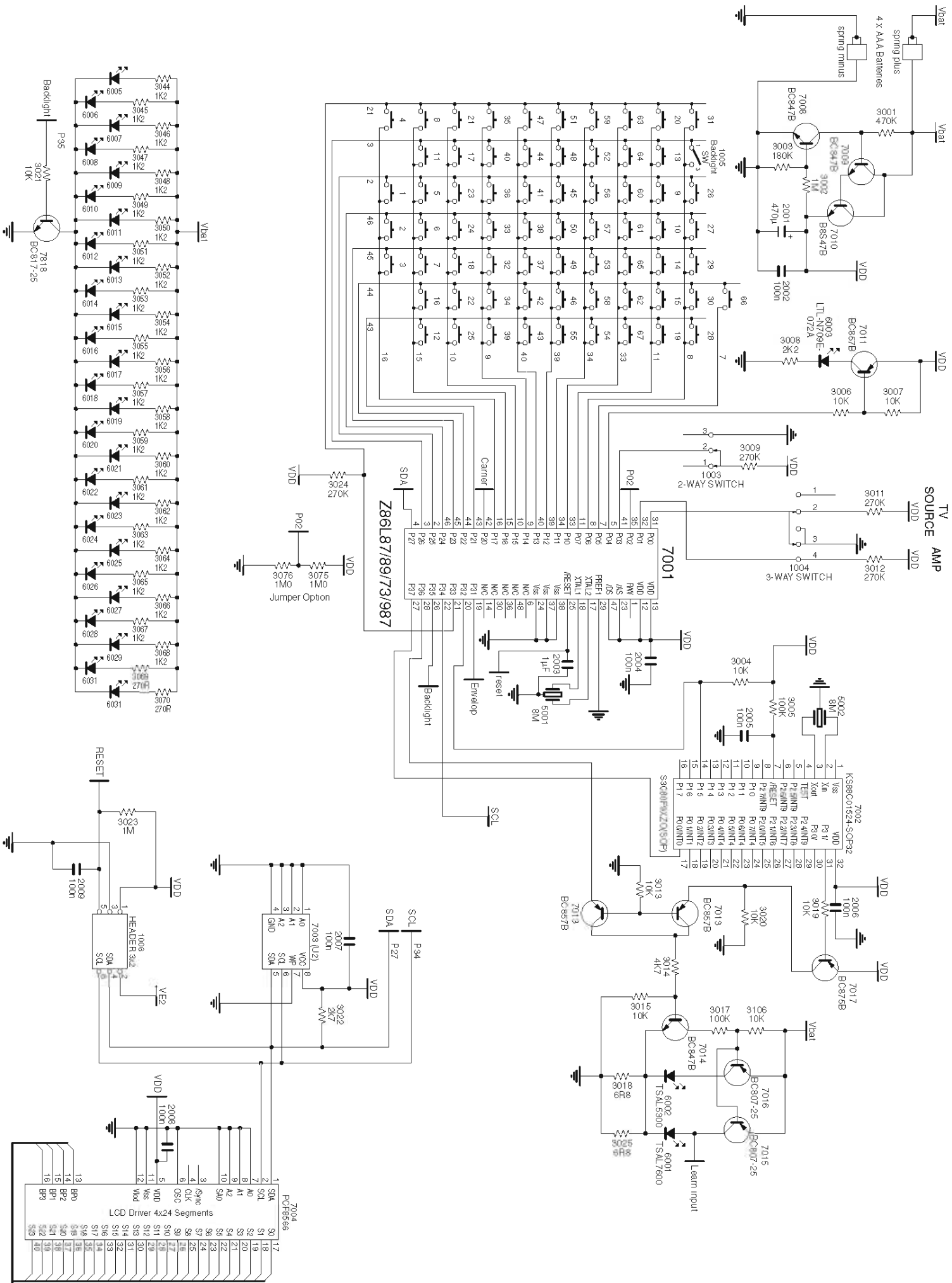

REMOTE CONTROL PANELS

RAV356
(U, C models)

RAV357
(R, T, K, A,
B, G, L, J models)

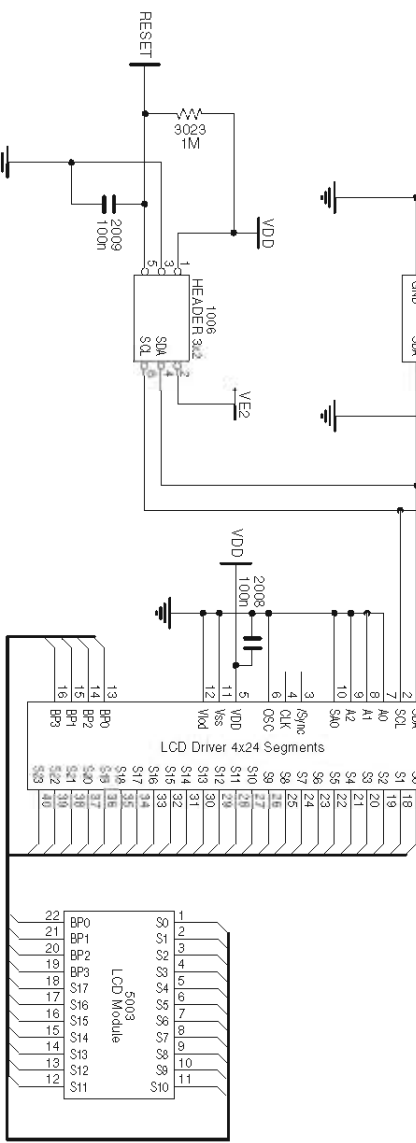
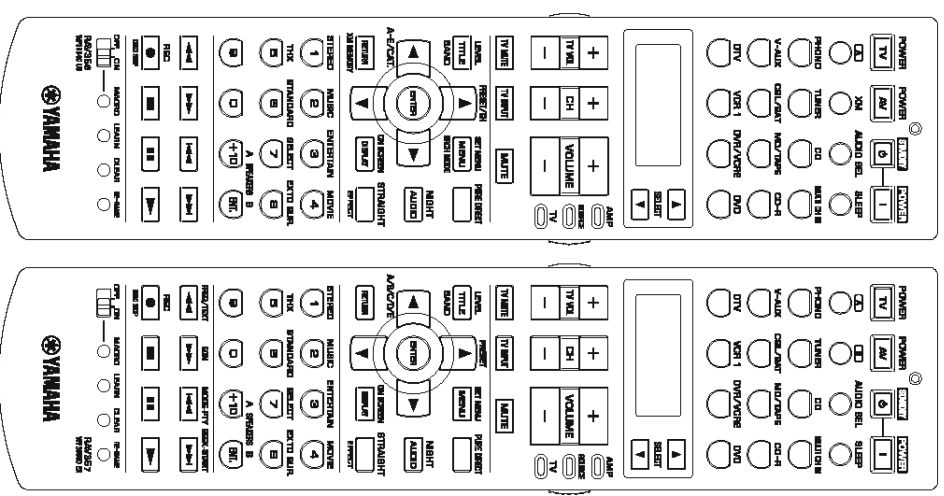

1 ■ REMOTE CONTROL RAV 20, 21

• SCHEMATIC DIAGRAM

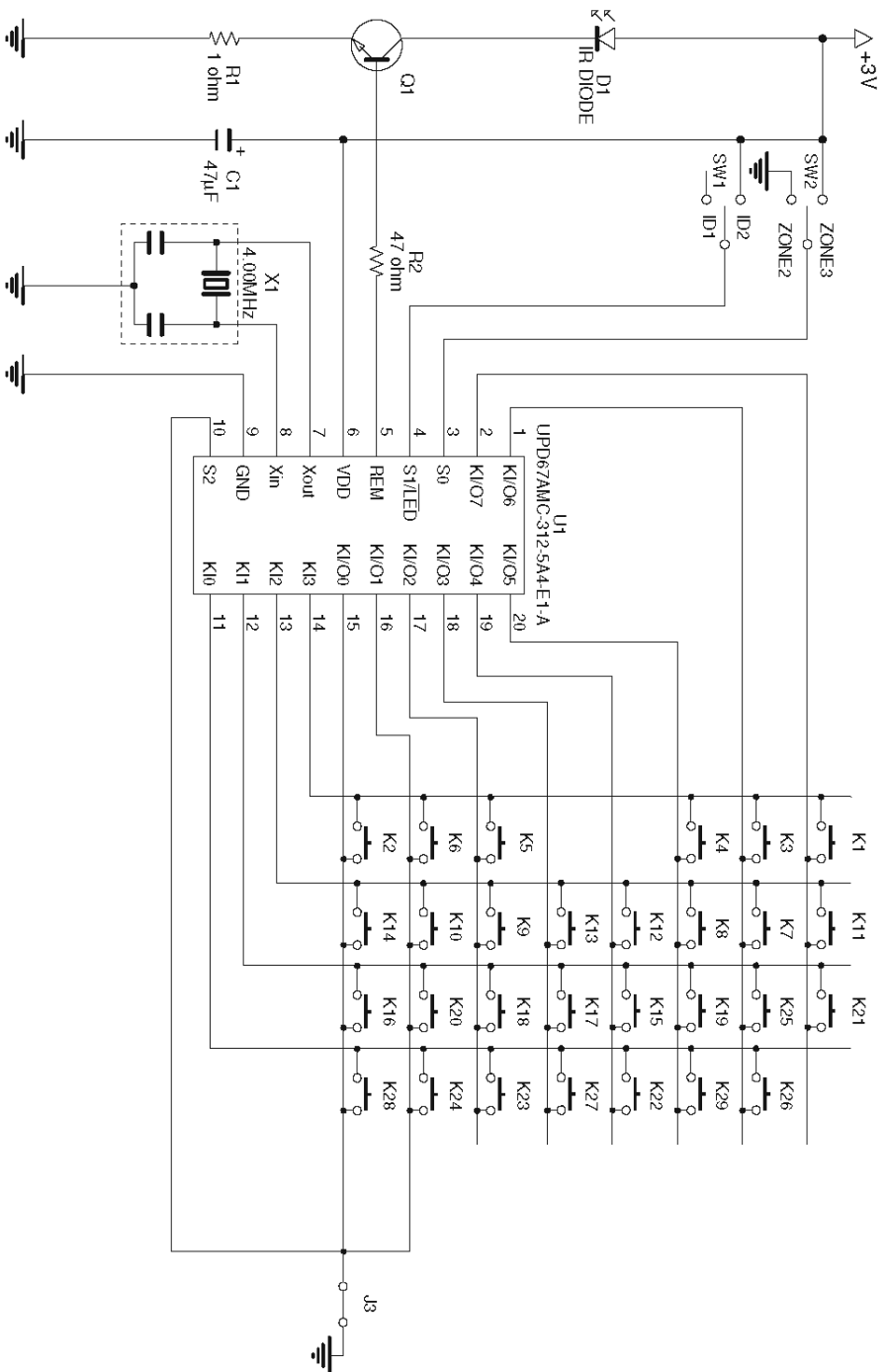

• REMOTE CONTROL PANELS RAV21 (U, C models)

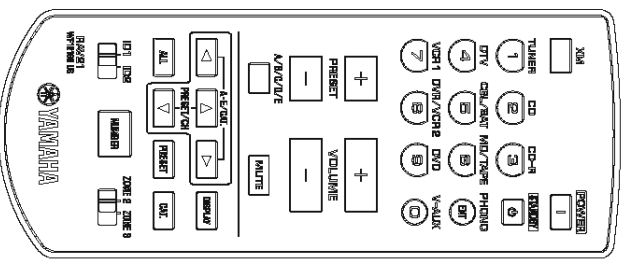

• REMOTE CONTROL PANELS RAV20 (R, T, K, A, B, G, L, J models)

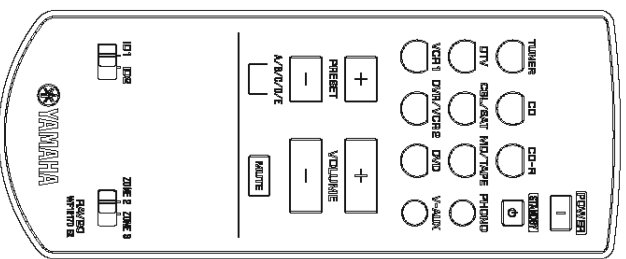

• KEY NO. LAYOUT

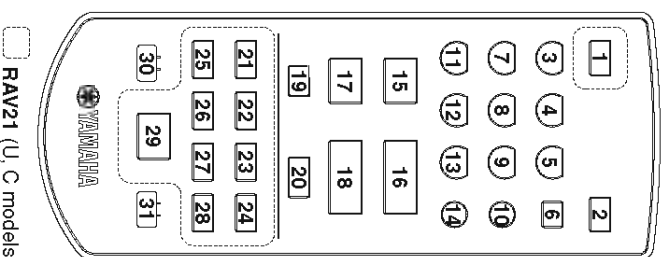

• KEY CHART

YAMAHA IR CODE TABLE				
Key No.	Key Name Type B1 (ZONE/XM)	Code		
		ID 1	ZONE 3	ID 2
1	XM	7A-B8	7A-B9	7D-2F
2	POWER	7E-BA	7A-ED	7D-64
3	TUNER	7A-D2	7A-F3	7D-66
4	1 (NUMBER + TUNER)	7A-61		7D-A1
	CD	7A-D1	7A-F2	7D-67
	2 (NUMBER + CD)	7A-62		7D-A2
5	CD-R	7A-D4	7A-F5	7D-6B
	3 (NUMBER + CD-R)	7A-63		7D-A3
6	STANDBY	7E-BB	7A-EE	7D-63
	DTV	7A-D9	7A-F6	7D-6C
7	4 (NUMBER + DTV)	7A-64		7D-A4
	CBL/SAT	7A-CC	7A-F7	7D-69
8	5 (NUMBER + CBL/SAT)	7A-65		7D-A5
	MD/TAPE	7A-D3	7A-F4	7D-6A
9	6 (NUMBER + MD/TAPE)	7A-66		7D-A6
	PHONO	7A-D0	7A-F1	7D-65
10	ENT + PHONO	7A-BF		7D-3F
11	VCR 1	7A-D6	7A-F9	7D-6D
	7 (NUMBER + VCR 1)	7A-67		7D-A7
12	DVR/VCR 2	7A-D7	7A-FA	7D-6E
	8 (NUMBER + DVR/VCR 2)	7A-68		7D-A8
13	DVD	7A-CD	7A-FC	7D-6F
	9 (NUMBER + DVD)	7A-69		7D-A9
14	V-AUX	7A-D8	7A-F0	7D-68
	0 (NUMBER + V-AUX)	7A-60		7D-A0
15	PRESET (+)	7A-10		7D-F5
16	VOLUME (+)	7A-DA	7A-FD	7D-70
17	PRESET (-)	7A-11		7D-F6
18	VOLUME (-)	7A-DB	7A-FE	7D-71
19	A/B/C/D/E	7A-12		7D-F7
20	MUTE	7A-DC	7A-FF	7D-72
21	A-E/CAT. ▽	7A-6E		7D-35
22	PRESET/CH Δ	7A-6A		7D-31
23	A-E/CAT. ▽	7A-6C		7D-33
24	DISPLAY	7A-72		7D-39
25	ALL	7A-B5		7D-2C
26	PRESET/CH ▽	7A-6B		7D-32
27	PRESET	7A-B7		7D-2E
28	CAT.	7A-B6		7D-2D
29	NUMBER			
30	ID 1/ID 2			
31	ZONE 2/ZONE 3			

Parts List for Carbon Resistors

Value	1/4W Type Part No.	1/6W Type Part No.	Value	1/4W Type Part No.	1/6W Type Part No.
1.0 Ω	HJ35 3100	HF85 3100	10 kΩ	HF45 7100	HF45 7100
1.8 Ω	HJ35 3180	*	11 kΩ	HF45 7110	HF45 7110
2.2 Ω	HJ35 3220	HF85 3220	12 kΩ	HJ35 7120	HF85 7120
3.3 Ω	HJ35 3330	HF85 3330	13 kΩ	HF45 7130	HF45 7130
4.7 Ω	HJ35 3470	HF85 3470	15 kΩ	HF45 7150	HF45 7150
5.6 Ω	HJ35 3560	HF85 3560	18 kΩ	HF45 7180	HF45 7180
10 Ω	HF45 4100	HF45 4100	22 kΩ	HF45 7220	HF45 7220
15 Ω	HJ35 4150	HF85 4150	24 kΩ	HF45 7240	HF45 7240
22 Ω	HF45 4220	HF45 4220	27 kΩ	HJ35 7270	HF85 7270
27 Ω	HJ35 4270	HF85 4270	30 kΩ	HF45 7300	HF45 7300
33 Ω	HF45 4330	HF45 4330	33 kΩ	HF45 7330	HF45 7330
39 Ω	HJ35 4470	HF85 4390	36 kΩ	HF45 7360	HF45 7360
47 Ω	HF45 4470	HF45 4470	39 kΩ	HF45 7390	HF45 7390
56 Ω	HF45 4560	HF45 4560	47 kΩ	HF45 7470	HF45 7470
68 Ω	HF45 4680	HF45 4680	51 kΩ	HF45 7510	HF45 7510
75 Ω	HF45 4750	HF45 4750	56 kΩ	HF45 7560	HF45 7560
82 Ω	HF45 4820	HF45 4820	62 kΩ	HF45 7620	HF45 7620
91 Ω	HF45 4910	HF45 4910	68 kΩ	HF45 7680	HF45 7680
100 Ω	HF45 5100	HF45 5100	82 kΩ	HF45 7820	HF45 7820
110 Ω	HJ35 5110	HF85 5110	91 kΩ	HF45 7910	HF45 7910
120 Ω	HF45 5120	HF45 5120	100 kΩ	HF45 8100	HF45 8100
150 Ω	HF45 5150	HF45 5150	110 kΩ	HF45 8110	HF45 8110
160 Ω	HJ35 5160	*	120 kΩ	HF45 8120	HF45 8120
180 Ω	HF45 5180	HF45 5180	150 kΩ	HF45 8150	HF45 8150
200 Ω	HF45 5200	HF45 5200	180 kΩ	HF45 8180	HF45 8180
220 Ω	HF45 5220	HF45 5220	220 kΩ	HJ35 8220	HF85 8220
270 Ω	HF45 5270	HF45 5270	270 kΩ	HF45 8270	HF45 8270
330 Ω	HF45 5330	HF45 5330	300 kΩ	HF45 8300	HF45 8300
390 Ω	HF45 5390	HF45 5390	330 kΩ	HF45 8330	HF45 8330
430 Ω	HF45 5430	HF45 5430	390 kΩ	HJ35 8390	HF85 8390
470 Ω	HF45 5470	HF45 5470	470 kΩ	HF45 8470	HF45 8470
510 Ω	HF45 5510	HF45 5510	560 kΩ	HJ35 8560	HF85 8560
560 Ω	HF45 5560	HF45 5560	680 kΩ	HJ35 8680	HF85 8680
680 Ω	HF45 5680	HF45 5680	820 kΩ	HJ35 8820	HF85 8820
820 Ω	HF45 5820	HF45 5820	1.0 MΩ	HF45 9100	HF45 9100
910 Ω	HF45 5910	HF45 5910	1.2 MΩ	HJ35 9120	*
1.0 kΩ	HF45 6100	HF45 6100	1.5 MΩ	HJ35 9150	HF85 9150
1.2 kΩ	HF45 6120	HF45 6120	1.8 MΩ	HJ35 9180	HF85 9180
1.5 kΩ	HF45 6150	HF45 6150	2.2 MΩ	HJ35 9220	HF85 9220
1.8 kΩ	HF45 6180	HF45 6180	3.3 MΩ	HJ35 9330	HF85 9330
2.0 kΩ	HJ35 6200	HF85 6200	3.9 MΩ	HJ35 9390	*
2.2 kΩ	HF45 6220	HF45 6220	4.7 MΩ	HJ35 9470	HF85 9470
2.4 kΩ	HJ35 6240	HF85 6240			
2.7 kΩ	HF45 6270	HF45 6270			
3.0 kΩ	HF45 6300	HF45 6300			
3.3 kΩ	HF45 6330	HF45 6330			
3.6 kΩ	HJ35 6360	HF85 6360			
3.9 kΩ	HF45 6390	HF45 6390			
4.7 kΩ	HF45 6470	HF45 6470			
5.1 kΩ	HF45 6510	HF45 6510			
5.6 kΩ	HF45 6560	HF45 6560			
6.8 kΩ	HF45 6680	HF45 6680			
8.2 kΩ	HF45 6820	HF45 6820			
9.1 kΩ	HF45 6910	HF45 6910			

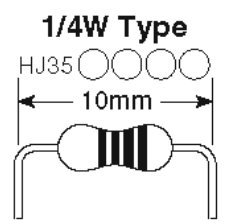

1/4W Type
HJ35 ○○○○

← 10mm →

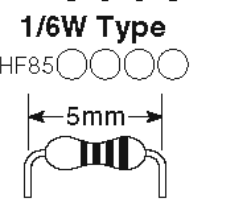

1/6W Type
HF85 ○○○○

← 5mm →

* : Not available

RX-V1600/DSP-AX1600

